

15-20 F150 ACC BRACKET RELOCATION (EXCL. PLATINUM) PART #FD-4000

PARTS LIST:

1	ACC Sensor Main Bracket
1	ACC Adapter Bracket
1	Ranger Support Bracket
1	8mm x 30mm Bolt Plate
3	8-1.25mm x 25mm Button Head Bolts
7	8mm x 24mm x 2mm Flat Washers
4	8mm Lock Washers
4	8mm Hex Nuts
6	6-1.0mm x 20mm Button Head Bolts
12	6mm x 18mm x 1.6mm Flat Washers
6	6mm Lock Washers
6	6mm Hex Nuts
1	5mm Wrench
1	4mm Wrench

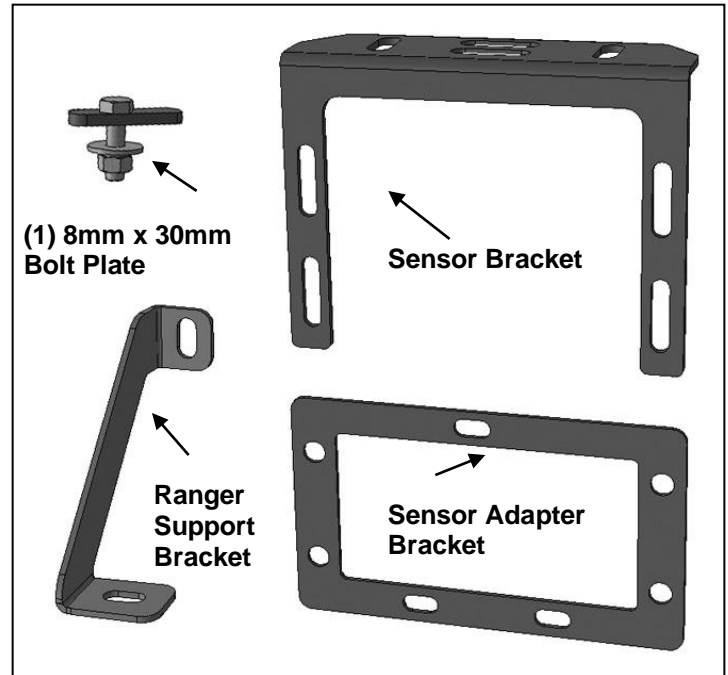

PROCEDURE:

REMOVE CONTENTS FROM BOX. VERIFY ALL PARTS ARE PRESENT. READ INSTRUCTIONS CAREFULLY BEFORE STARTING INSTALLATION. CUTTING/DRILLING IS REQUIRED. IMPORTANT: F-150 MODELS WITH CHROME GRILLE FEATURING CROSSBAR(S) AT TOP OPENING IN GRILLE BELOW HOOD, (SEE EXAMPLE FIGURE 1), MAY PARTIALLY BLOCK SENSOR RELOCATION, INSTALLATION NOT RECOMMENDED.

1. Open the hood and remove the plastic cover from the top of the grille, between the grille and the radiator, (F-150 see Figure 2, Ranger see Figure 20).

2. Select the procedure for your particular vehicle:

F-150 models (see exclusion information above)

- a. Remove the hardware attaching the top of the grille to the radiator core support, (Figure 2).
- b. Release the clips attaching the top of the driver/left plastic cover surrounding the headlight, (Figure 2). Carefully pull the cover next to the grille, straight outward to release from the clips, (Figure 3). Remove the hardware attaching the driver/left side of the grille to the inner body. Repeat this Step to release the passenger/right side of the grille. Pull grille out slightly, unplug inner shutter mechanism and remove grille, (Figure 4). Place grille on a clean working surface.
- c. Unplug and remove ACC sensor from factory bumper if equipped, (Figure 5). **NOTE:** Sensor is located behind the driver/left plastic bumper pad. Pull pad straight out to release from clips.
- d. Remove the sensor from the factory bracket. Note the design of the sensor.

Vehicles with early style ACC with tabs on ends:

- a. Select the Sensor Mounting Bracket. Attach the ACC sensor to the **back** of the Mounting Bracket with the included (3) 6mm x 20mm Button Head Bolts, (6) 6mm Flat Washers, (3) 6mm Lock Washers and (3) 6mm Hex Nuts, (Figure 6). **IMPORTANT:** Do not overtighten 6mm hardware or damage to the sensor could result.

Vehicles with late style ACC with tabs on top and bottom:

- a. Select the Adapter Bracket, **(Figure 7)**.
- b. Attach the ACC sensor to the **back** of the Adapter with the included (3) 6mm x 20mm Button Head Bolts, (6) 6mm Flat Washers, (3) 6mm Lock Washers and (3) 6mm Hex Nuts, **(Figure 7)**.
- c. Attach the ACC sensor and Adapter to the **front** of the Mounting Bracket with the included (3) 6mm x 20mm Button Head Bolts, (6) 6mm Flat Washers, (3) 6mm Lock Washers and (3) 6mm Hex Nuts, **(Figure 8)**.
- d. Remove the plastic hold down bracket from the back of the shutter mechanism, **(Figure 9)**. Temporarily remove the driver/left shutter blades.
- e. Insert the sensor and Bracket assembly into the space between the back of the grille and the front of the shutter blades. With sensor facing forward, find a flat location on the underside of the grille for the top of the Bracket, **(Figure 10)**. Make sure the sensor assembly is pointed forward only.
- f. Mark the location of the slots on the top of the Bracket onto the underside of the grille, **(Figure 10)**. Use (2) slot locations to attach Bracket, **(Figure 11)**. Drill (2) 5/16" holes through the top of the grille. **IMPORTANT:** Make sure there is clearance for hardware before drilling. Avoid the plastic ribs on the top of the cover, **(Figure 12)**.
- g. Attach the Bracket with sensor to the underside of the grille with the included (2) 8mm x 25mm Button Head Bolts, (4) 8mm Flat Washers, (2) 8mm Lock Washers and (2) 8mm Hex Nuts, **(Figures 12—14)**. **NOTE:** Additional hardware has been included, use is optional.
- h. Adjust the sensor up or down to center between the wide horizontal bars on the grille, **(Figure 3)**. When properly installed, sensor should be pointed directly forward.
- i. Locate the wire harness behind the bumper leading to the sensor, **(Figure 15)**. Unwrap the outer cover to locate and separate the wires for the sensor plug only. This will allow the sensor harness to extend up to the new mounting location. On installations retaining the factory bumper, it will be necessary to cut an opening into the rubber splash guard to insert the plug and wire harness through, **(Figure 16)**. Find a location approximately 3" in from the front edge of the splash guard. Check length with grille temporarily held in place and once properly extended, rewrap all wires.
- j. Next, cut an approximately 2" x 1" hole in the bottom of the grille for the sensor plug, **(Figure 17)**.
- k. With assistance, place the grille in position but leave loose. Push the harness plug up through the hole in the grille, **(Figure 18)**. Plug the harness into the sensor. Reinstall the shutter blades and mechanism, **(Figure 19)**. Fully attach the grille, headlight surrounds and top cover.

Ranger Models

- a. Remove the hardware attaching the top of the grille, next to the headlights, **(Figure 20)**.
- b. Remove the plastic cover from behind the grille, **(Figure 20)**. Carefully release the clips at the bottom of the grille. Remove grille and place grille on a clean working surface, **(Figure 21)**.
- c. Unplug and remove ACC sensor from the back of the bumper, **(Figure 22)**. **NOTE:** Sensor is located behind the passenger/right side of the bumper.
- d. Temporarily reinstall the plastic cover below the hood release mechanism, **(Figure 20)**.
- e. Select the Adapter Bracket, **(Figure 23)**. Attach the ACC sensor to the **front** of the Adapter with the included (3) 6mm x 20mm Button Head Bolts, (6) 6mm Flat Washers, (3) 6mm Lock Washers and (3) 6mm Hex Nuts, **(Figure 23)**.
- f. Attach the ACC sensor and Adapter to the **front** of the Mounting Bracket with the included (3) 6mm x 20mm Button Head Bolts, (6) 6mm Flat Washers, (3) 6mm Lock Washers and (3) 6mm Hex Nuts, **(Figure 24)**.
- g. Select the 8mm Bolt Plate, **(Figure 25)**. Insert the Bolt Plate into the large hole in the driver/left side of the core support next to the hood release mechanism, **(Figure 26)**.
- h. Select the Support Bracket. Temporarily attach the Support Bracket to the Bolt Plate with (1) 8mm Flat Washer, (1) 8mm Lock Washer and (1) 8mm Hex Nut, **(Figure 26)**. Snug hardware.
- i. Make sure the end of the Support Bracket is flat against the plastic cover. Mark the location of the slot in the Support Bracket onto the top of the plastic cover, **(Figure 26)**.

- j. Remove the Support Bracket and the plastic cover.
 - k. Drill a 5/16" hole through the previously marked location. Reinstall the cover and Support Bracket, **(Figure 26)**.
 - l. Temporarily attach the Bracket assembly with sensor to the underside of the plastic cover and Support Bracket with (1) 8mm x 25mm Button Head Bolt, (2) 8mm Flat Washers, (1) 8mm Lock Washer and (1) 8mm Hex Nut, **(Figure 27)**.
 - m. With Bracket assembly parallel to the radiator and sensor pointing forward, mark the location of the remaining slots onto the cover, **(Figure 27)**. The Bracket features multiple slots, use a slot location on the other end of the Bracket assembly, **(Figure 27)**.
 - n. Remove the Bracket and sensor assembly and plastic cover.
 - o. Drill (1) 5/16" hole through the cover in the second marked location. **IMPORTANT:** Make sure there is clearance for hardware before drilling, **(Figure 28)**.
 - p. Reinstall cover, sensor assembly with Relocation Bracket and Support Bracket, **(Figure 29)**.
 - q. Remove the clips attaching the bottom of the plastic bumper cover. Locate the wire harness behind the bumper leading to the sensor, **(Figure 30)**. Unwrap the outer cover to locate and separate the wires for the sensor plug only, **(Figure 31)**. This will allow the sensor harness to extend up to the new mounting location. Once extended, rewrap the harness with electrical tape (not included).
 - r. Plug the harness into the sensor, **(Figure 32)**. Fully attach the grille and top cover.
 - s. Adjust the sensor up or down to center between the wide horizontal bars on the grille and fully tighten all hardware, **(Figure 33)**.
3. Do periodic inspections to the installation to make sure that all hardware is secure and tight.

By installing this product, you are accepting liability for potential changes in the characteristics/sensitivity of your adaptive cruise control system. After installation of this product, your adaptive cruise control module may require recalibration by a Ford technician.



(Fig 1) IMPORTANT: Installation not recommended on 2018-on F150 models with chrome horizontal bar or bars at top of grille (arrow) . The thick, reflective chrome horizontal bars may interfere with sensor operation. **NOTE:** Lariat model with chrome package pictured. Applies to chrome versions of grille only



(Fig 2) F-150 Models. Remove cover from top of grille (arrow). Remove hardware attaching top of grille to radiator core support. Release clips attaching top of plastic headlight surrounds (arrows above headlights)



(Fig 3) F-150 Models. Pull out plastic headlight surround to access grille hardware along sides



(Fig 4) F-150 Models. Unplug harness leading to shutter in grille. Remove grille assembly

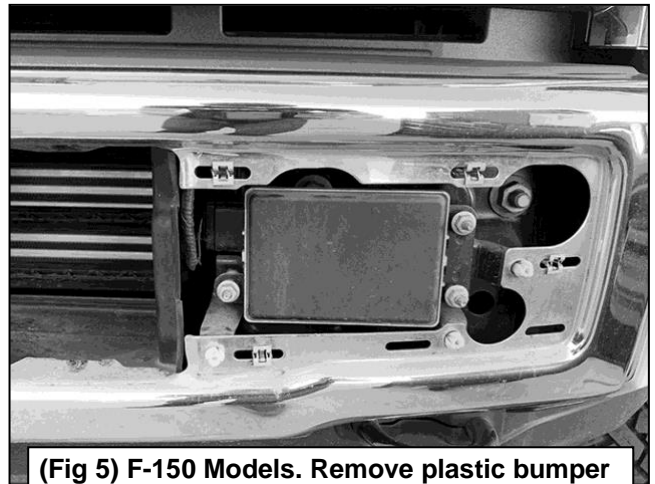

(Fig 5) F-150 Models. Remove plastic bumper pad to locate, unplug and remove sensor

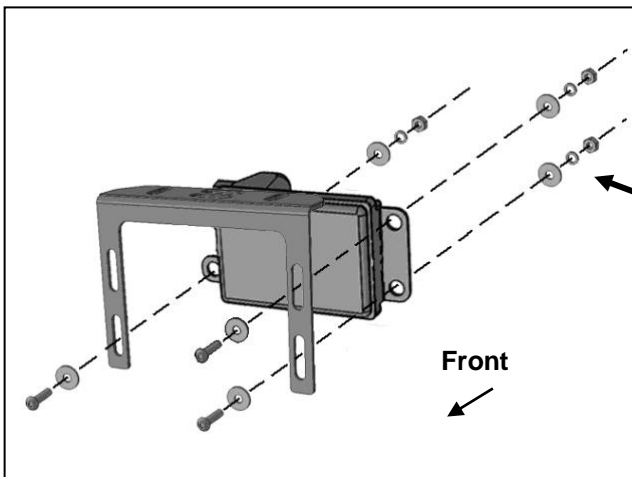

(Fig 6) F-150 Models. Attach "early" style sensor with tabs on sides to back of Relocation Bracket

- (3) 6mm x 20mm Button Head Bolts
- (6) 6mm Flat Washers
- (3) 6mm Lock Washers
- (3) 6mm Hex Nuts

- (3) 6mm x 20mm Button Head Bolts
- (6) 6mm Flat Washers
- (3) 6mm Lock Washers
- (3) 6mm Hex Nuts

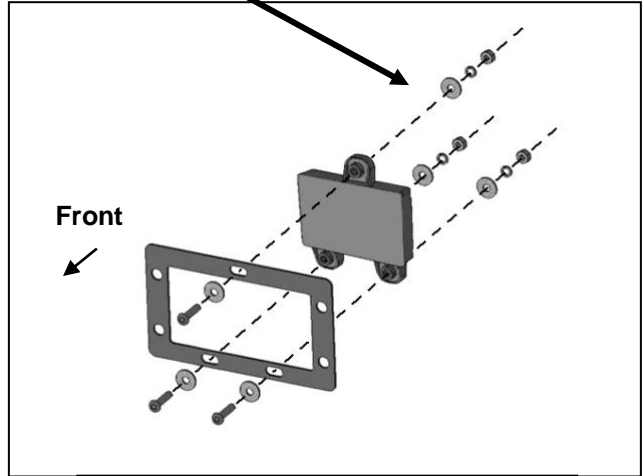

(Fig 7) F-150 Models. Attach late style Sensor to Adapter Bracket

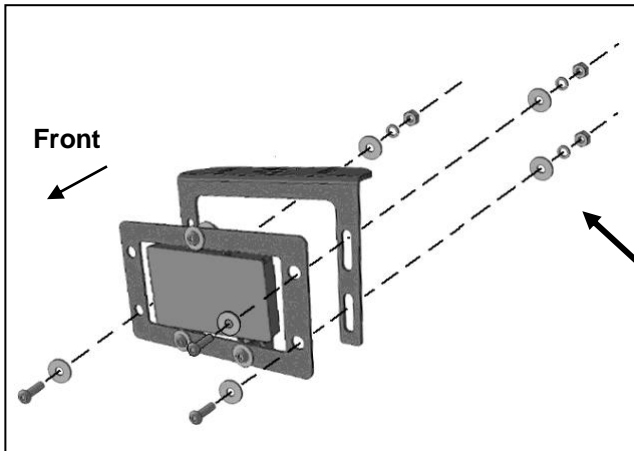

(Fig 8) F-150 Models. Attach Adapter Bracket and sensor to front of Relocation Bracket. NOTE: Install with sensor on back of Adapter Bracket

- (3) 6mm x 20mm Button Head Bolts
- (6) 6mm Flat Washers
- (3) 6mm Lock Washers
- (3) 6mm Hex Nuts

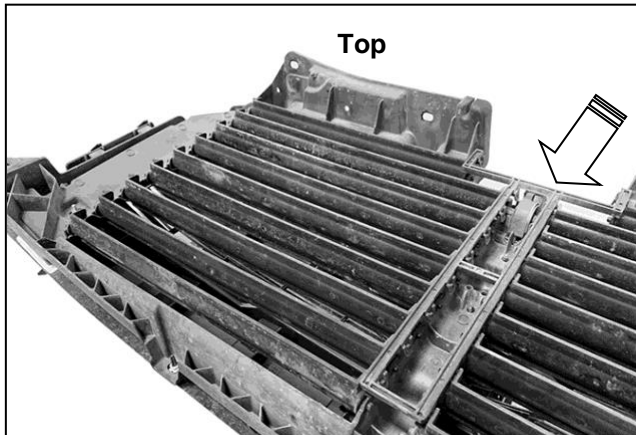

(Fig 9) F-150 Models. Shutter assembly in back of grille. Remove center lock (arrow) to disassemble driver/left side of shutter assembly

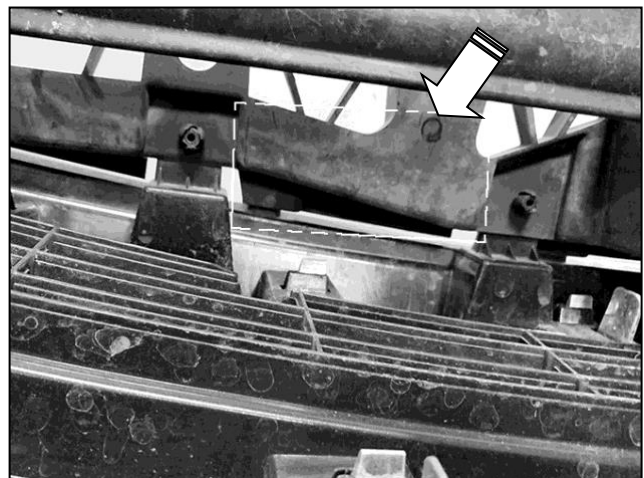

(Fig 10) F-150 Models. Hold Relocation Bracket assembly up to underside of top of grille. Locate flat location to mount assembly (dashed line). Mark suitable hole locations on Bracket (see Fig 11 & 12) to drill.

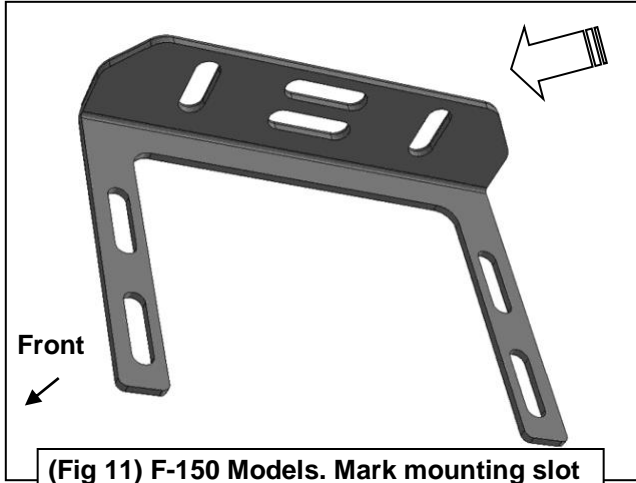

(Fig 11) F-150 Models. Mark mounting slot locations onto underside of grille (Fig 10)

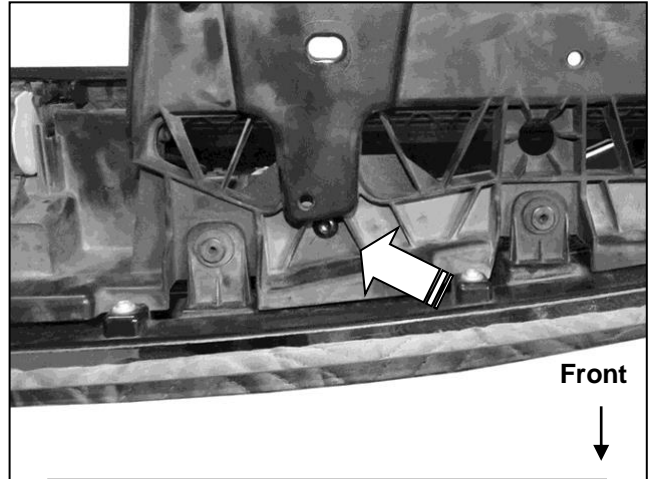

(Fig 12) F-150 Models. Before drilling holes, make sure holes and hardware will be clear of reinforcing ribs molded into the top of the grille (arrow)

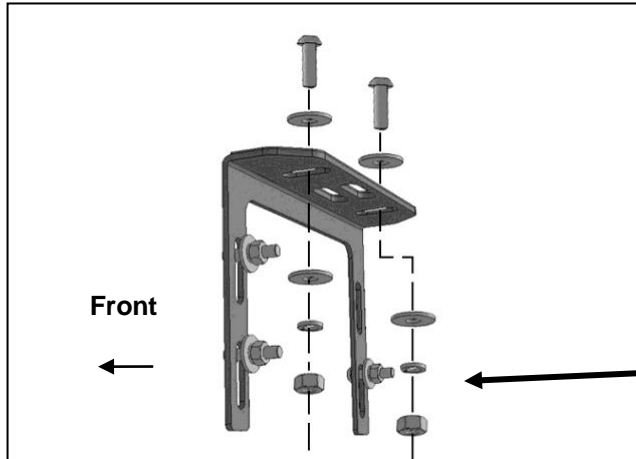

(Fig 13) F-150 Models. Attach sensor and Bracket to previously drilled holes. (2) Bolts are preferred

- (2) 8mm x 25mm Button Head Bolts
- (4) 8mm Flat Washers
- (2) 8mm Lock Washers
- (2) 8mm Hex Nuts

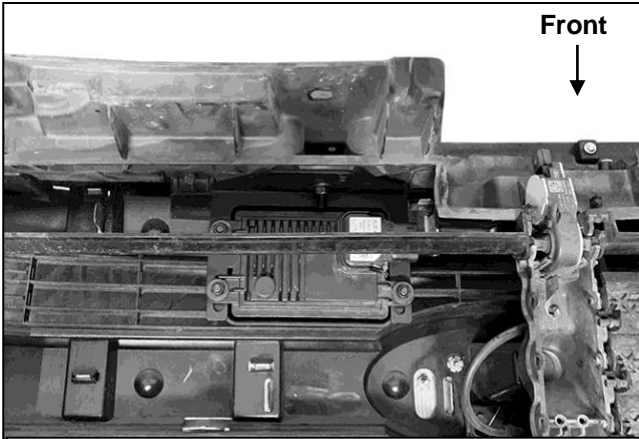

(Fig 14) F-150 Models. Attach Relocation Bracket and sensor to previously drilled holes. (2) Bolts are preferred, Bracket installed with (1) Bolt for example only

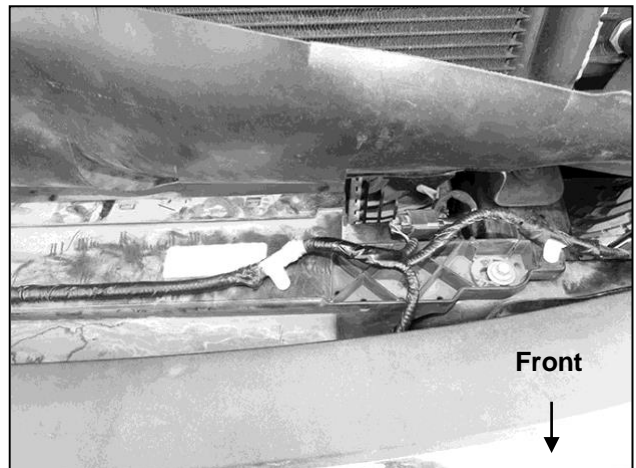

(Fig 15) F-150 Models. Locate the wiring harness to the sensor. From the plug, unwrap approximately 24" of the harness.

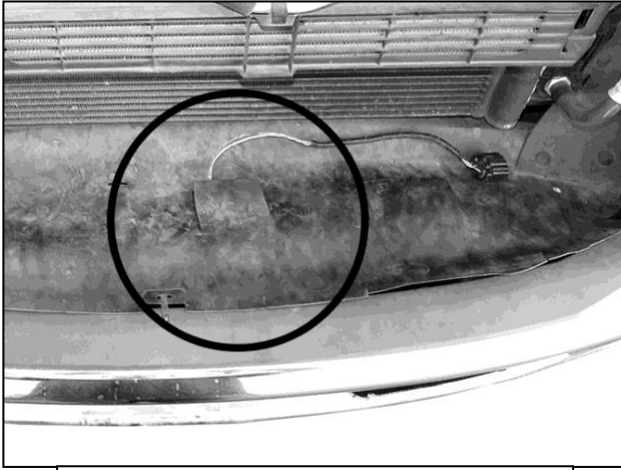

(Fig 16) F-150 Models. On installations using factory bumper, cut an opening in the rubber splash guard approximately 3" back from front edge

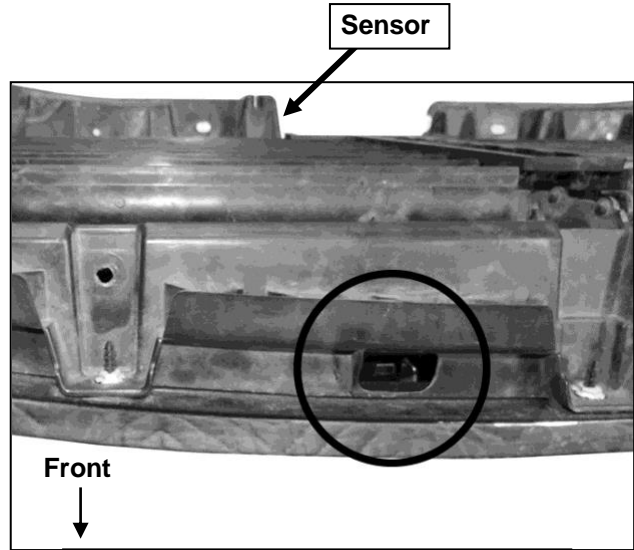

(Fig 17) F-150 Models. Cut an opening approximately 2" x 1" hole in the bottom of the grille



(Fig 18) F-150 Models. Push sensor plug up through opening. Pull harness up between shutter blades and grille to sensor. NOTE: Temporarily remove shutter blades as necessary for access to harness and sensor



(Fig 19) F-150 Models. Plug harness into sensor. Check fit of harness, secure harness to grille. Rewrap wiring harness. Reinstall shutter blades. Reinstall grille assembly

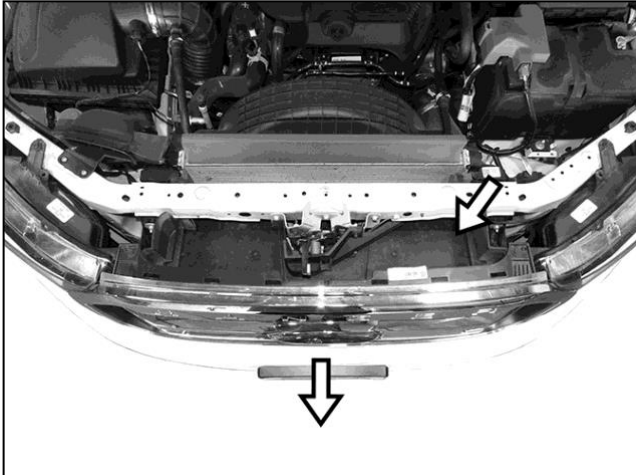

(Fig 20) Ranger Models. Remove cover between top of radiator and grille. Remove screws attaching top of grille. Remove cover around latch to access and remove inner plastic cover in front of radiator (arrows)



(Fig 21) Ranger Models. Release clips on bottom of grille to remove grille.

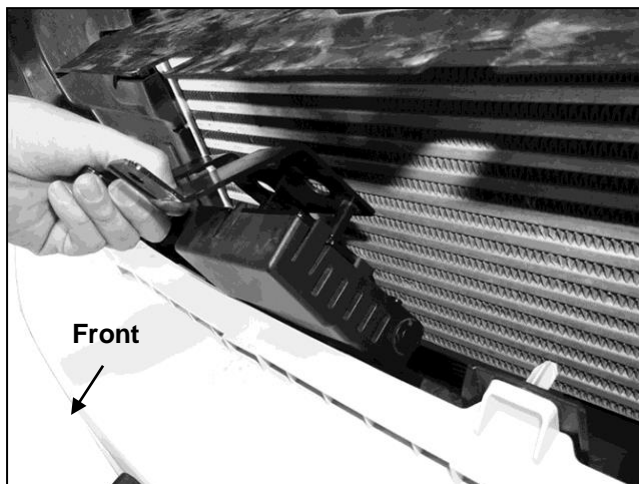

(Fig 22) Ranger Models. Unplug and remove sensor from behind bumper

- (3) 6mm x 20mm Button Head Bolts
- (6) 6mm Flat Washers
- (3) 6mm Lock Washers
- (3) 6mm Hex Nuts

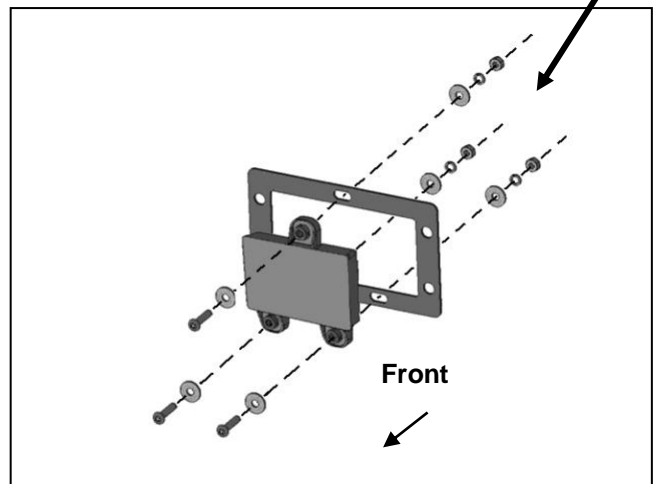

(Fig 23) Ranger Models. Remove sensor from factory bracket. Attach sensor to front of Adapter Bracket

- (3) 6mm x 20mm Button Head Bolts
- (6) 6mm Flat Washers
- (3) 6mm Lock Washers
- (3) 6mm Hex Nuts

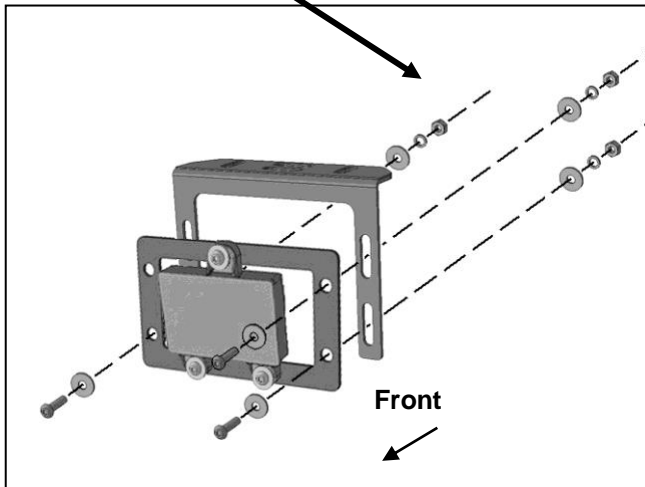

(Fig 24) Ranger Models. Attach Adapter Bracket with sensor to front of Relocation Bracket

- 8mm Bolt Plate
- 8mm Flat Washer
- 8mm Lock Washer
- 8mm Hex Nut

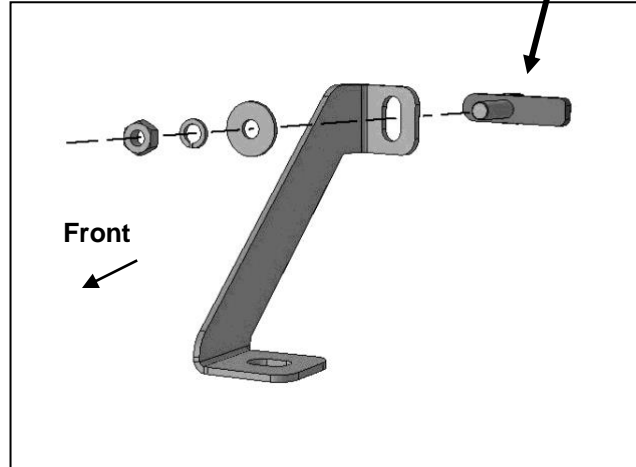

(Fig 25) Ranger Models. Reinstall plastic inner shield (see Fig 28). Attach Support Bracket to front of radiator core support



(Fig 26) Ranger Models. Reinstall plastic inner shield. Attach Support Bracket to front of radiator core support. Mark location of slot in Support Bracket onto top of plastic shield. Remove shield and drill a 5/16" hole through marked location. Reinstall shield

- 8mm x 25mm Button Head Bolt
- (2) 8mm Flat Washers
- 8mm Lock Washer
- 8mm Hex Nut

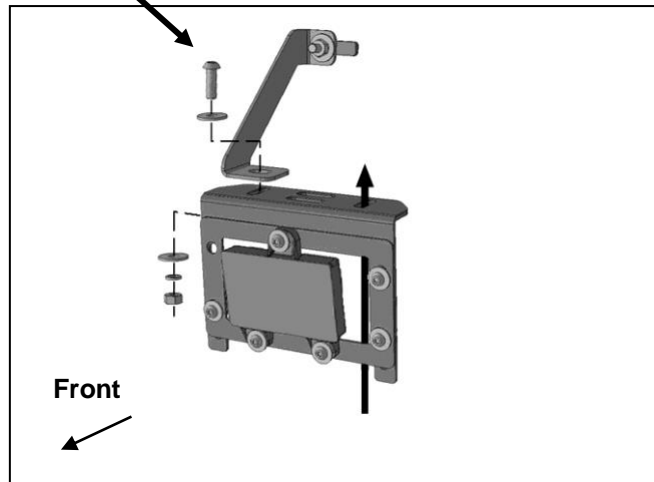

(Fig 27) Ranger Models. Reinstall plastic inner shield. Attach Support Bracket to Sensor Relocation Bracket assembly. Align sensor to face straight ahead. Mark location for 2nd mounting bolt. Remove sensor assembly and plastic shield

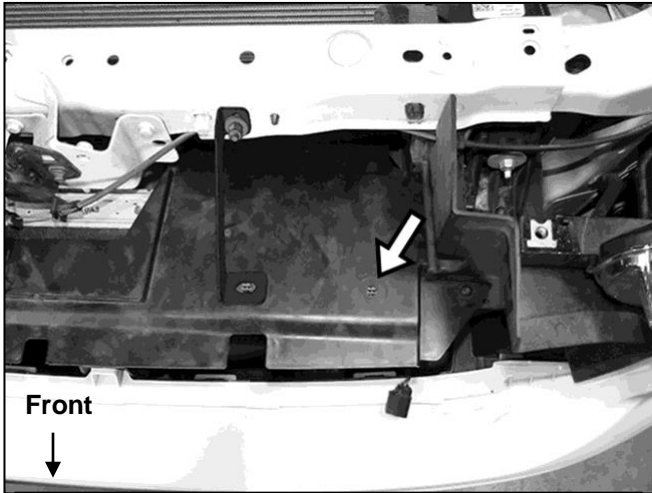

(Fig 28) Ranger Models. Drill 5/16" hole in 2nd location (arrow). Reinstall plastic inner shield

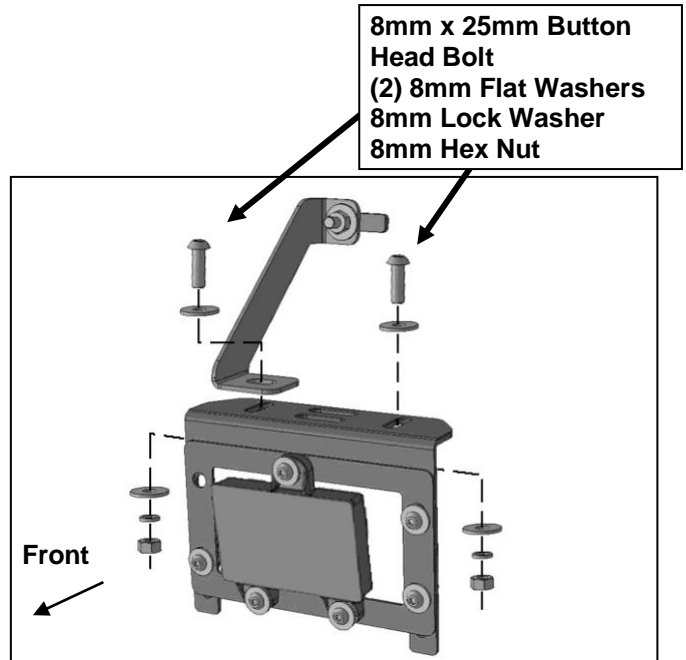

(Fig 29) Ranger Models. Reattach sensor Relocation Bracket assembly to Support Bracket and plastic shield

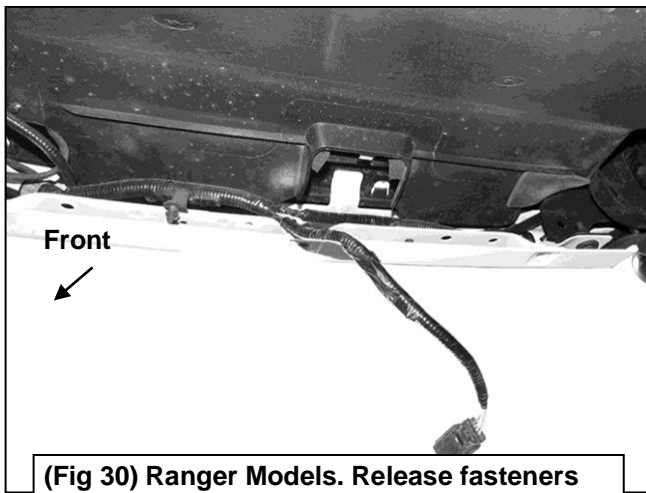

(Fig 30) Ranger Models. Release fasteners attaching bottom of plastic bumper. Release clips attaching the wiring harness.

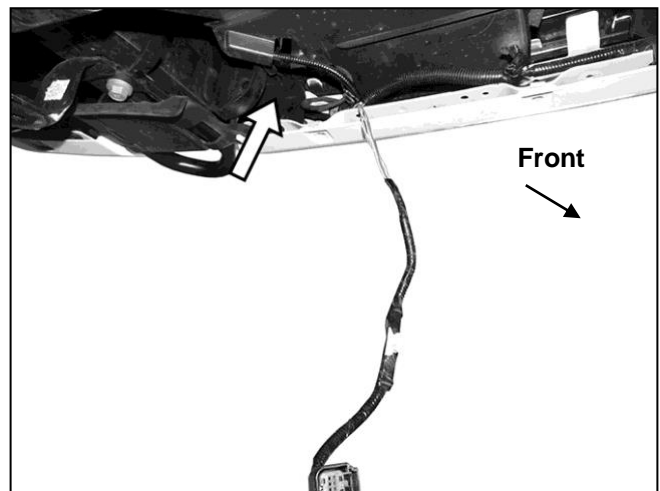

(Fig 31) Ranger Models. Unwrap the wiring harness for the sensor. Insert harness through opening (arrow) and up to sensor. Check length. Rewrap all wiring harnesses

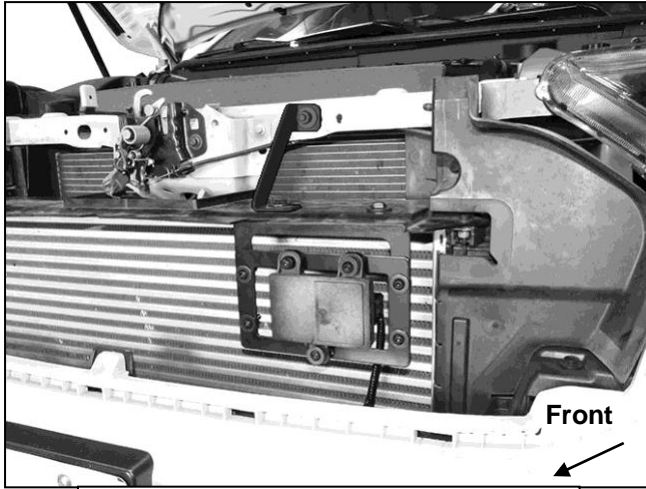

(Fig 32) Ranger Models. Plug harness into sensor. Check sensor alignment before tightening hardware

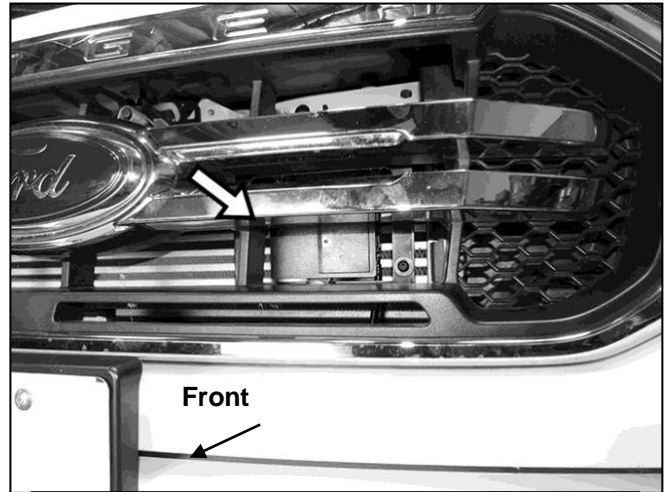

(Fig 33) Ranger Models. Adjust sensor up or down as needed. Check sensor alignment before final tightening of all hardware