

## 2015-2019 Toyota 4Runner Hilina Front Winch Bumper Part #TR-19339

### PARTS LIST:

1	BA Front Center Section Winch Bumper	2	10-1.5mm x 30mm Button Head Bolts
1	Bull Nose Hoop	2	10-1.5mm x 45mm Hex Bolts
1	Driver/left Frame Support Bracket	2	10-1.5mm x 25mm Hex Bolts
1	Passenger/right Frame Support Bracket	6	10mm x 30mm x 2.5mm Flat Washers
1	Driver/left Plastic Bumper Bracket	4	10mm x 20mm x 2mm Flat Washers
1	Passenger/right Plastic Bumper Bracket	6	10mm Lock Washers
1	Driver/left Light Bar "L" Bracket	4	10mm Hex Nuts
1	Passenger/right Light Bar "L" Bracket	5	8-1.25mm x 25mm Hex Bolts
1	License Plate Bracket	2	8-1.25mm x 16mm Hex Bolts
2	Plastic Plugs	12	8mm x 24mm x 2mm Flat Washers
1	Edge Trim (1.5m length cut to fit)	2	8mm Lock Washers
2	12-1.25mm x 30mm Fine Tread Hex Bolts	5	8mm Nylon Lock Nuts
2	12mm x 24mm x 2.5mm Flat Washers	1	6mm Wrench
2	12mm Lock Washers		

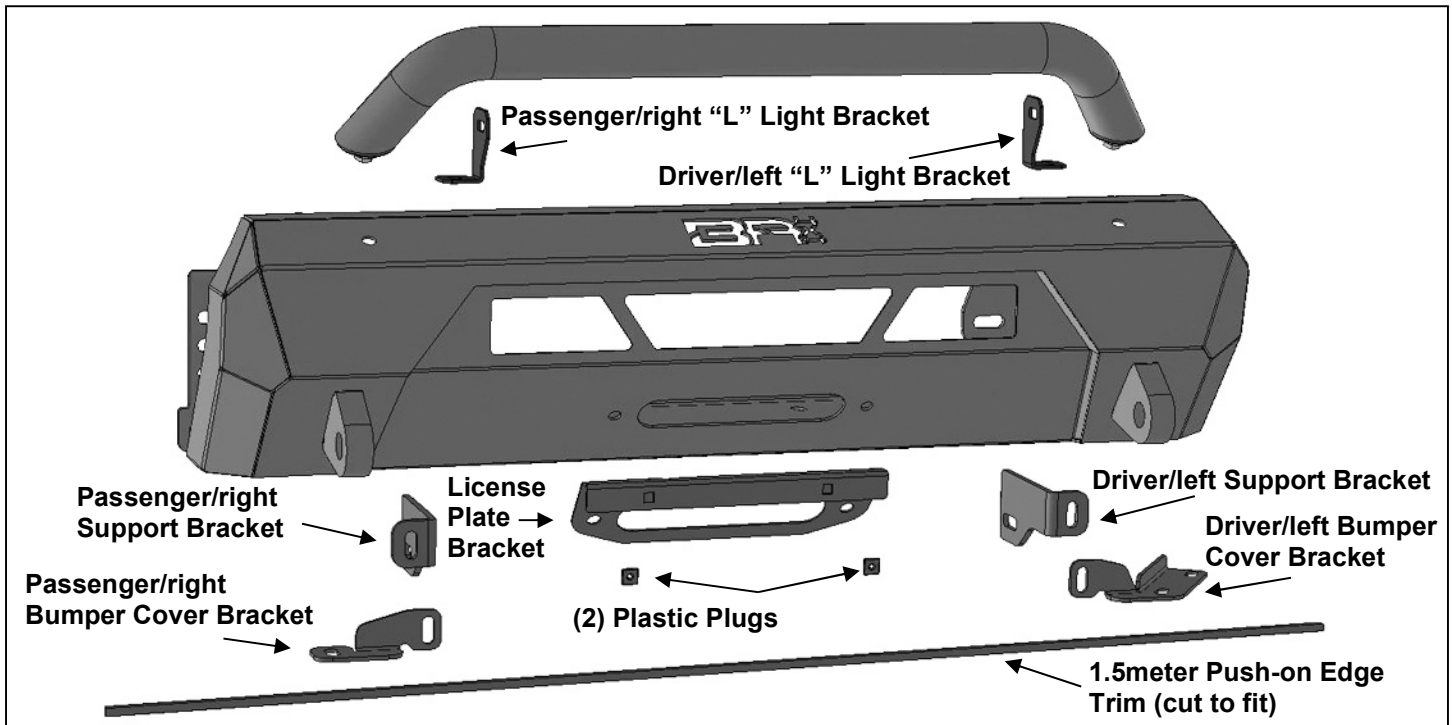

### PROCEDURE:

REMOVE CONTENTS FROM BOX. VERIFY ALL PARTS ARE PRESENT. READ INSTRUCTIONS CAREFULLY BEFORE STARTING INSTALLATION. ASSISTANCE IS RECOMMENDED TO AVOID POSSIBLE INJURY OR DAMAGE TO THE VEHICLE. CUTTING OE FRONT BUMPER IS REQUIRED.

1. Start under the driver/left side of the bumper and remove the hardware attaching the bottom of the plastic bumper cover at both ends and along the center, (**Figure 1**). Remove the hardware attaching

- both ends of the bumper cover to the wheel openings and bottom of the fenders, (**Figure 2**). Unplug the fog lights if equipped. Remove skid plate if necessary.
- Open the hood and remove the plastic cover from the top of the radiator and grille, (**Figure 3**). Next, remove the hardware attaching the top of the plastic bumper cover and grille to the radiator support.
  - With assistance, pop the ends off of the inner clips and pull the bumper cover off and away from the vehicle, (**Figure 4**). Place bumper face down a soft, clean, stable work surface.
  - Remove the aluminum cross bar and brackets from the end of the frame, (**Figure 4 & 5**).
  - On the driver/left side of the bumper cover, locate the point where the molded in side of the bumper cover ends approximately 2-3/4" below the outer corner of the grille, (**Figures 6 & 11**). Place a mark at this point. Locate the matching point on the passenger/right side of the bumper and mark the point below the grille. Use removable tape (masking tape for example) or a sharp marking pen and straight edge to draw a straight reference line from point to point across the back of the cover, (**Figures 7 & 8**).
  - Next, place a mark 1-1/4" below the driver/left outer corner of the grille, (**Figure 9**). Repeat to mark the passenger/right side of the bumper cover. Use a sharp marking pen and straight edge to draw a straight cut line from point to point across the back of the cover below the grille, (**Figures 9 & 10**).
  - Place a mark 1-1/2" in from each end of the reference line drawn in **Step 4**, (**Figure 9**). Draw a straight vertical line up from the reference line to the cut line from **Step 5**. Draw an angled line from the intersection of the cut line to the end point on the reference line, (**Figures 10 & 11**). Repeat this Step for the remaining side of the bumper cover. This will be the horizontal cut across the bumper cover.
  - Locate the molded vertical rib on the back of the bumper, (**Figure 11**). Start at the end of the reference line (**Step 4**) and use a sharp marker to mark a cut line along the inside of the bumper, approximately 1/4" below the top edge of the rib. Mark the cut line all the way to the bottom of the bumper cover on both sides of the bumper.
  - Locate and remove the (2) plastic mounts from the center of the bumper cover below the grille, (**Figure 12**).
  - Select the Body Armor Center Bumper. Hold the Bumper up in place to check clearance. **NOTE:** On models equipped with vertical plastic shroud on driver/left side of the radiator, cut shroud to clear Bumper as needed, (**Figure 13**).
  - Use a sharp knife or hacksaw blade to carefully cut the plastic bumper cover along the previously marked lines, (**Figure 14**). **IMPORTANT:** For best fit, leave an extra 1/4" of material when cutting to make any adjustments as necessary.
  - Reinstall the cut plastic bumper cover. Hold the Body Armor Bumper up in place to check the fit of the Bumper against the cut plastic bumper cover and trim cover as necessary for best fit, (**Figure 15**). Reuse the (8) factory hex bolts to temporarily attach the Bumper Assembly to the end of the frame, (**Figure 19**). Leave hardware loose. Do not install the Body Armor Bumper at this time, only check the fit against the plastic bumper cover. Once all trimming is completed, cover the cut edge of the bumper cover with the included Edge Trim, (**Figure 15**). Cut the Edge Trim to fit as required. Reattach the fog light wiring harness at this time.
  - Next, move the Body Armor Front Bumper to a stable, clean and flat surface.
  - Bull Nose Installation** (installation optional, not recommended on models with Toyota Safety Sense-P technology package with grille mounted sensor).
    - Remove rubber plugs from top of Bumper, (**Figure 16**).
    - Attach Bull Nose to top of Bumper with included (2) 10mm x 25mm Hex Bolts, (2) 10mm Lock Washers and (2) 10mm Flat Washers, (**Figure 16**). Tighten hardware.
  - Center LED light installation** (sold separately).
    - Select the driver/left "L" Light Bracket, (**Figure 17**). Use the provided (1) 8mm x 25mm Hex Bolt, (2) 8mm x 24mm Flat Washers and (1) 8mm Nylon Lock Nut to attach the "L" Bracket to the mounting tabs on the back of the Bumper. Leave hardware loose. Repeat to install the passenger/right Bracket.
    - Attach the LED light assembly to the "L" Brackets.

- c. Adjust the light as necessary and tighten hardware.
  - d. Follow the instructions included with the light to connect the wire harness to the vehicle.
- 16. Winch installation** (sold separately).
- a. Attach the winch to the center mounting plate on the back of the Bumper.
  - b. With assistance, hold the Bumper with winch up in position on the vehicle to check for clearance. Adjust or modify vehicle for clearance as necessary but do not install Body Armor Bumper at this time.
  - c. Attach cable guide (sold separately) to front of Bumper. **NOTE:** If front license plate is required, insert the included License Plate Bracket between the Bumper and the cable guide, **(Figure 18)**. Insert (2) Plastic Plugs into the square holes in the Bracket for license plate.
  - d. Follow instructions packaged with winch to install winch and connect electrical system.
- 17. License Plate Bracket alone**, (Bumper install without winch).
- a. Attach License Plate Bracket to Bumper with the included (2) 10mm Button Head Bolts, (4) 10mm Flat Washers and (2) 10mm Nylon Lock Nuts, **(Figure 18)**.
  - b. Insert (2) Plastic Plugs into the square holes in the Bracket for license plate.
- 18.** With assistance, position the Bumper Assembly up to the end of the frame. Temporarily support the weight of the Bumper. **WARNING:** To avoid possible injury or damage to the vehicle, do not proceed until the bumper is fully and safely supported.
- 19.** Reuse the (8) factory hex bolts to attach the Bumper Assembly to the end of the frame, **(Figures 19 & 20)**. Leave hardware loose at this time.
- a. Check fitment of Bumper and the trimmed plastic bumper cover, **(Figure 15)**. Trim plastic cover as required. Level and adjust the Bumper as needed and tighten hardware.
- 20.** Next, select the driver/left Bumper Support Bracket. Attach the Support Bracket to the threaded hole in the side of the frame with the included (1) 12-1.25mm x 30mm Fine Thread Hex Bolt, (1) 12mm Lock Washer and (1) 12mm Flat Washer, **(Figure 21)**. Do not fully tighten hardware.
- 21.** Select the driver/left Bumper Cover Bracket. Attach the Bumper Cover Bracket to the front of the bumper mounting plate. Insert (1) 10mm x 45mm Hex Bolt with (1) 10mm Flat Washer through the Cover Bracket, the mounting plate and the rear Bumper Support Bracket, **(Figure 21)**. Line up the (2) holes in the Cover Bracket with the (2) mounting holes in the bottom of the bumper cover. Attach the cover to the Bracket with the included (2) 8mm x 25mm Hex Bolts, (4) 8mm Flat Washers and (2) 8mm Nylon Lock Nuts, **(Figures 22 & 23)**. Fully tighten hardware. **NOTE:** Do not overtighten mounting hardware attaching plastic bumper cover to Bracket or damage to cover may result.
- 22.** Repeat **Steps 20 & 21** to attach the passenger/right Bumper Support Bracket and Bumper Cover Bracket. **NOTE:** Attach passenger/right bumper cover to Bracket with (1) 8mm x 25mm Hex Bolt, (2) 8mm Flat Washers and (1) 8mm Nylon Lock Nut.
- 23.** Align and adjust the bumper and cover and fully tighten all hardware.
- 24.** Reinstall the top plastic cover.
- 25.** Reinstall the skid plate, if equipped and removed.
- 26.** Do periodic inspections to the installation to make sure that all hardware is secure and tight.

**To protect your investment,** Do not use any type of polish or wax that may contain abrasives that could damage the finish. Mild soap may be used to clean the Bumper assembly.

## Driver/left side Installation Pictured

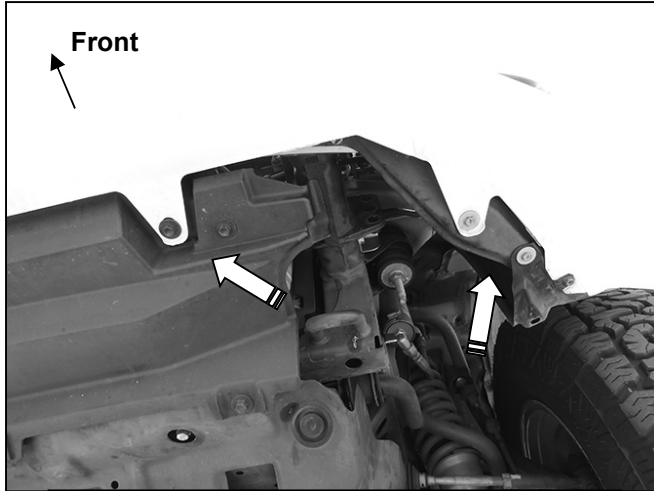

(Fig 1) Remove Skid Plate and hardware attaching bottom of plastic bumper cover

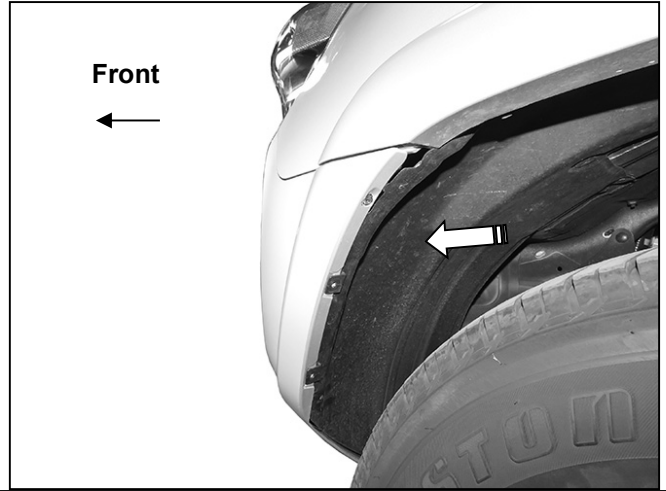

(Fig 2) Remove the hardware attaching the end of the bumper cover to the fender liner and front of fender



(Fig 3) Remove plastic cover (arrow) and hardware attaching top of bumper cover

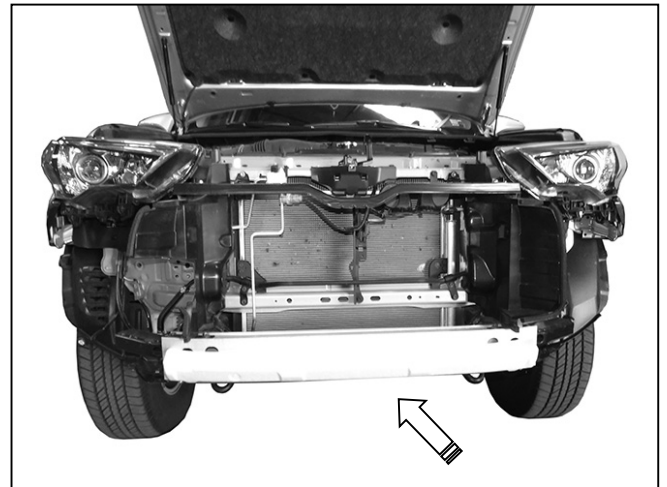

(Fig 4) Remove aluminum inner bumper and brackets



(Fig 5) Bumper removed

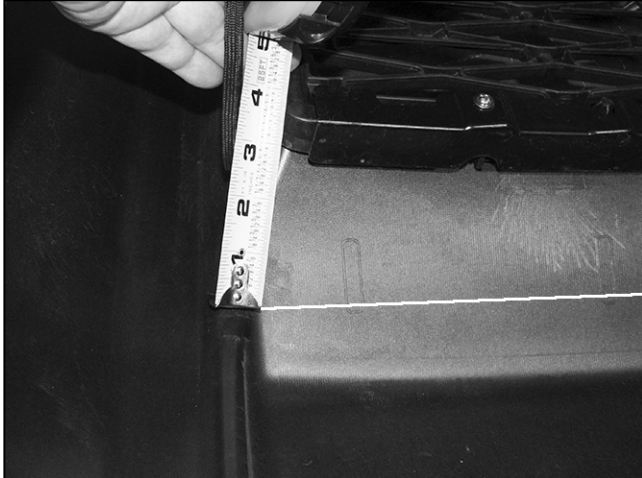

(Fig 7) Draw a straight line from side to side across back of bumper connecting the two marks (Fig 6)

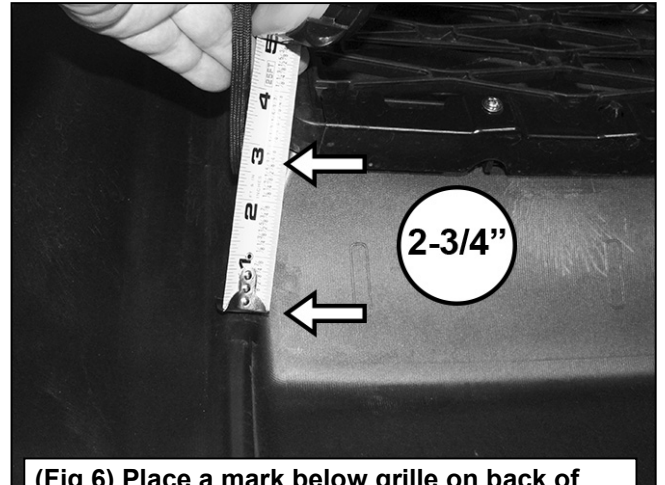

(Fig 6) Place a mark below grille on back of both sides of the bumper cover (see Figure 8)

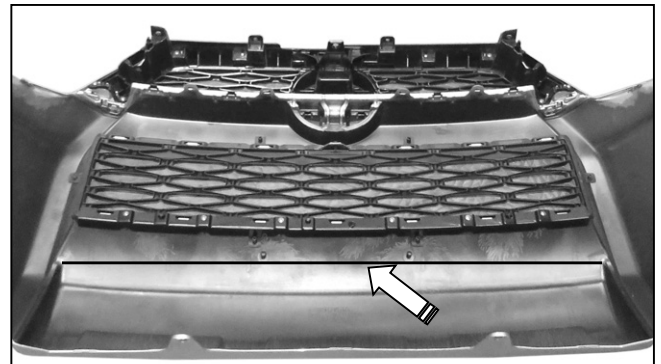

(Fig 8) Reference line on back of bumper. Do not cut along this line. Place vertical marks 1-1/2" in from each end of the reference line (see Figure 9)

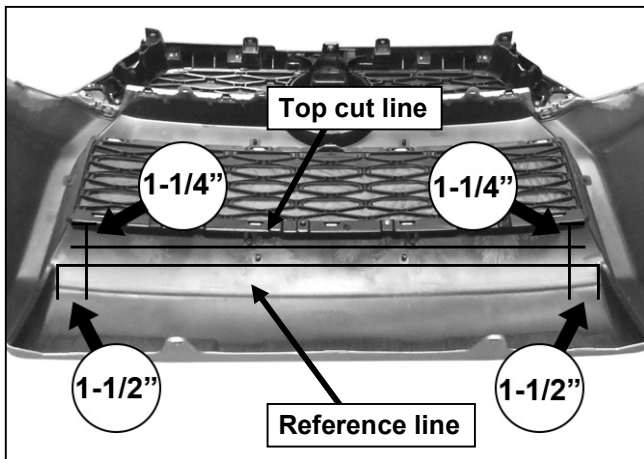

(Fig 9) Draw a second horizontal line 1-1/4" down from bottom of grille measured at the ends. Draw vertical lines up from the reference line to the upper cut line (see Figures 8 & 10)

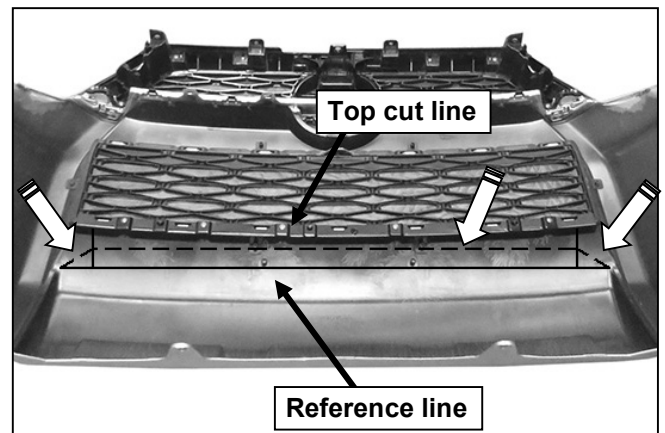

(Fig 10) Draw angled lines at the ends of the top cut line from the intersection of the vertical lines to the end of the reference line (see figures 8 & 9). The dashed line will be the horizontal top cut line (arrows). See figure 11 for vertical cut lines

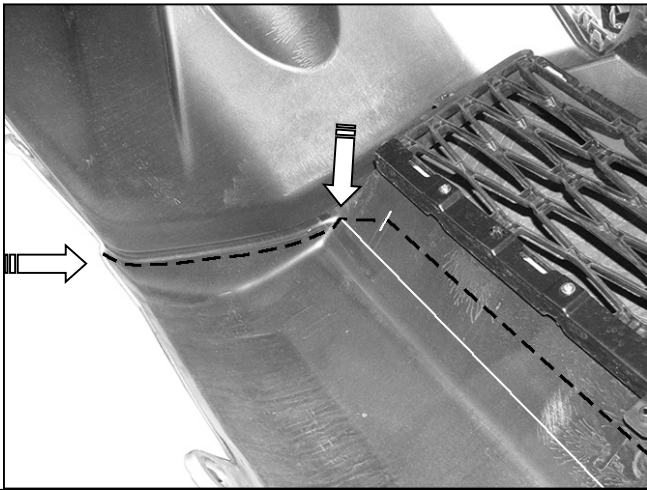

(Fig 11) For the vertical side cuts, draw a line 1/4" below the top of the rib on the back of the bumper cover. Line will start at the end of the reference line (figure 8) and run to the bottom edge of the bumper cover. Dashed line represents suggested starting point for cutting, additional trimming will be required for a proper fit

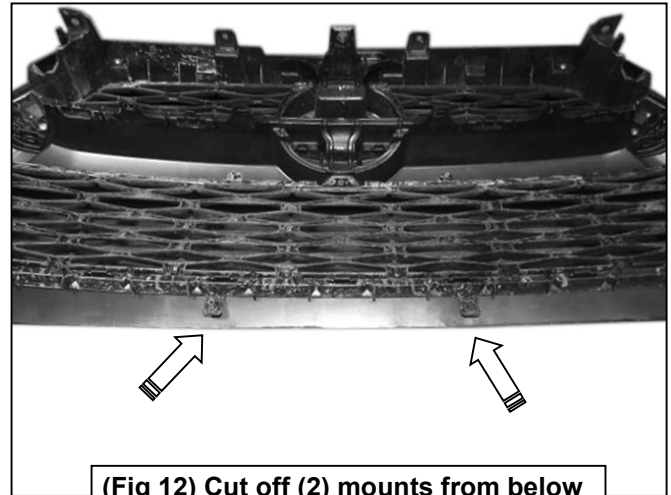

(Fig 12) Cut off (2) mounts from below grille to clear top of Bumper (arrows)

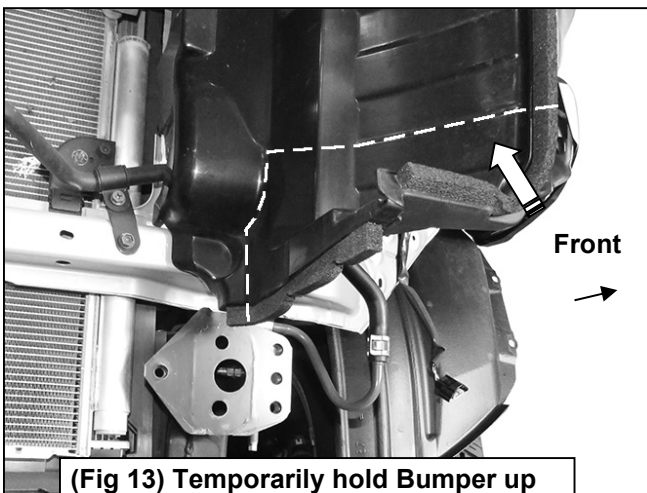

(Fig 13) Temporarily hold Bumper up in place to check fit and trim side shroud as necessary to clear Bumper



(Fig 14) Clean up cut along plastic and reinstall bumper cover

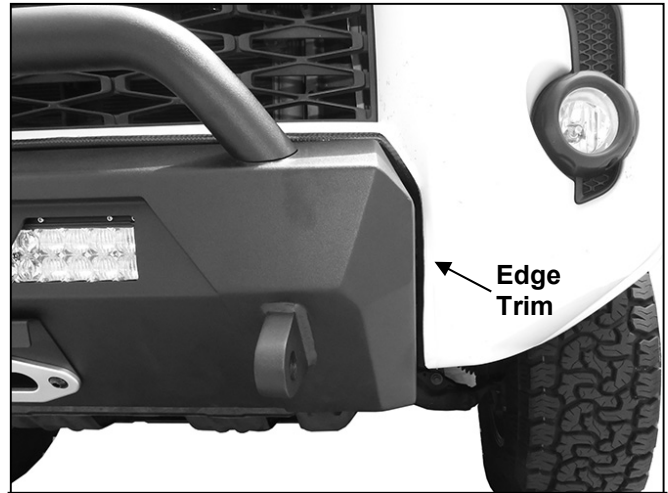

Edge Trim

(Fig 15) Temporarily hold Bumper up in place to check fit against bumper cover and trim as necessary before installing Edge Trim to cover. Do not install Bumper at this time.

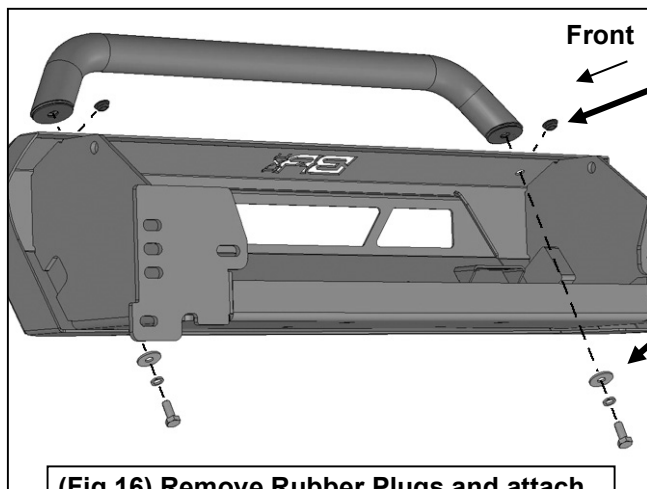

Front

Rubber Plugs

(2) 10mm x 25mm Hex Bolts  
(2) 10mm Lock Washers  
(2) 10mm Flat Washers

8mm x 25mm Hex Bolt  
(2) 8mm Flat Washers  
8mm Nylon Lock Nuts

(Fig 16) Remove Rubber Plugs and attach Bull Nose to top of Bumper (optional)

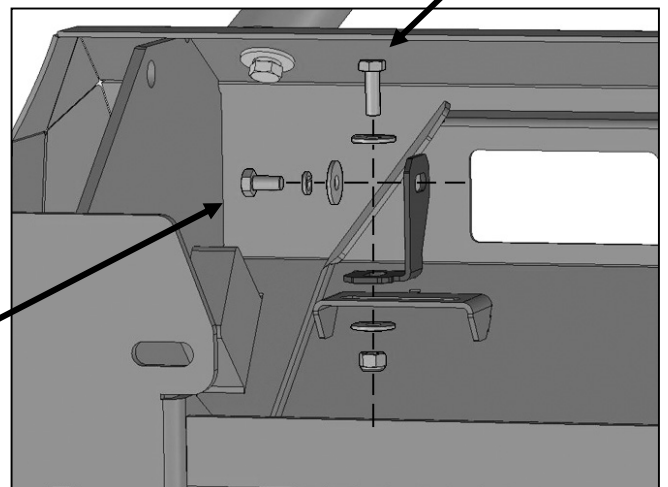

8mm x 16mm Hex Bolt  
8mm Lock Washer  
8mm Flat Washer

(Fig 17) Attach "L" Light Bracket to tab on back of Bumper (installation optional-light not included)

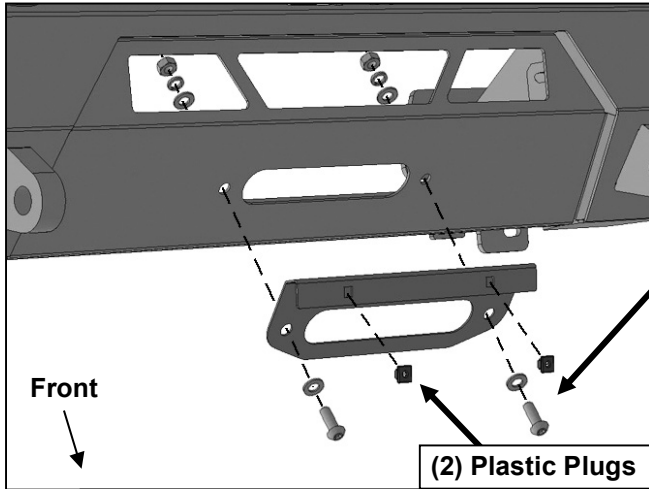

- (2) 10mm x 30mm Button Head Bolts
- (4) 10mm Flat Washers
- (2) 10mm Lock Washers
- (2) 10mm Hex Nuts

(Fig 18) Attach License Plate Bracket to front of Bumper, between fairlead (if equipped) and Bumper

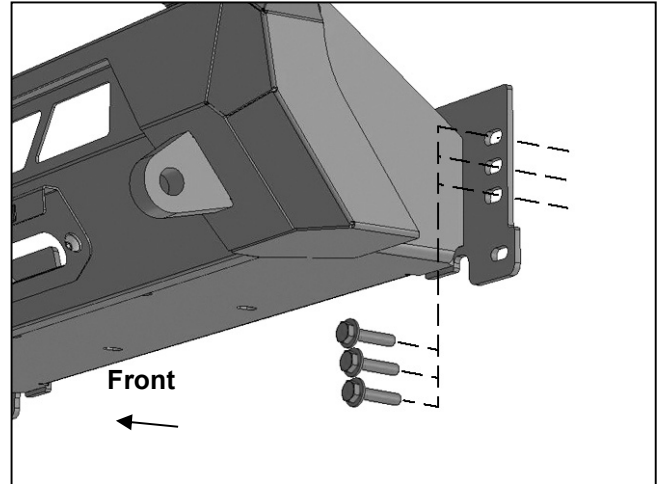

(Fig 19) Reuse factory hex bolts to attach Bumper to end of frame

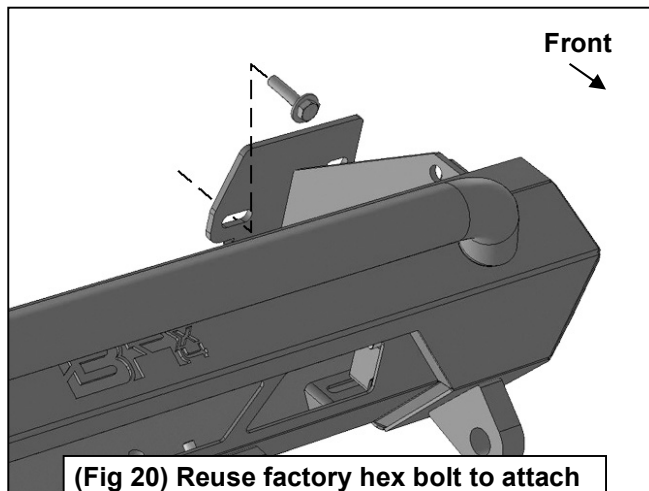

(Fig 20) Reuse factory hex bolt to attach inner slot on Bumper mounting plate

- 12-1.25mm x 30mm Fine Thread Hex Bolt
- 12mm Lock Washer
- 12mm Flat Washer

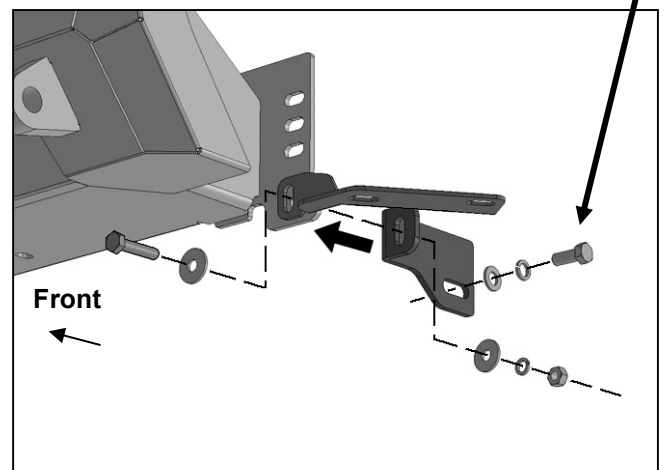

(Fig 21) Attach Bumper Support Bracket to outside of frame. Attach Cover Bracket to front of mounting plate on Bumper and to Support Bracket



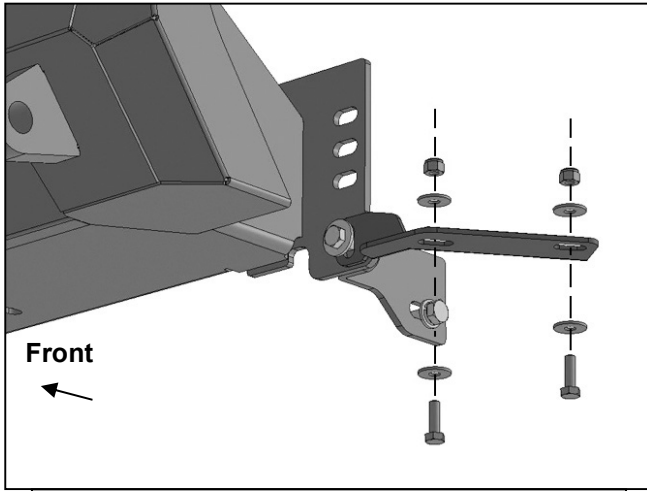

(Fig 22) Attach bottom of bumper cover to Cover Brackets. NOTE: Driver/left side pictured requires (2) 8mm Hex Bolts, passenger/right requires (1) 8mm Hex Bolt

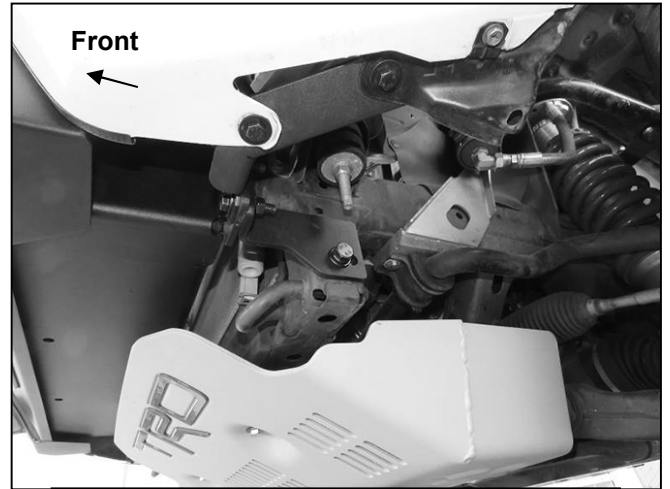

(Fig 23) Attach bottom of bumper cover to Cover Brackets (driver/left side pictured)