

Toyota 4WD Tacoma

Set Part # 31502

Rev 4 10/05/15

Step 1:

Prior to Installation:

- A) Bushwacker only approves installing the flares according to these written instructions with the hardware provided. **WARNING:** Failure to install according to these instructions will invalidate the warranty. This includes, but is not limited to using alternative installation methods, hardware, or materials. **DO NOT USE:** Loctite, SuperGlue, or similar products on the hardware or the flares.
- B) **Fit:** Verify the fit of the flares to vehicle. **(Some filing, sanding, or cutting may be necessary to ensure proper fit).**
- C) **Painting:** (Optional) if paint is desired it must be done prior to installing flares on the vehicle clean outer surface with a good grade degreaser. **DO NOT USE LACQUER THINNER OR ENAMEL REDUCER AS A DEGREASER.** Wipe outer surface thoroughly with a tack rag prior to paint. Paint flares using a high quality enamel, or polyurethane automotive paint. (Application of a primer coat is optional) If painting edge trim (not recommended), use a flex additive.
- D) **Performance:** Using larger Tires may increase the area required to turn the vehicle. Some Tire/Rim combinations may require lowering bump stops and or installing steering stops to prevent tire from contacting flare.
- E) **Exhaust System:** Modifications may be necessary to maintain a minimum 4" clearance between flares and exhaust pipes. (Exhaust gases should not vent directly onto flares)
- F) **Metal Protection:** All exposed fasteners and bare metal should be treated with red oxide primer BEFORE installing flares.

TOOLS FOR EASY INSTALLATION

- Jack and Jack Stands
- Metric Hex Wrench Set
- 3/8" Drill
- 5/16" Drill Bit

FLARE INSTALLATION PROCEDURES

Step 2: Edge Trim Installation

(See Illustration #1)

- A) Remove factory installed edge trim when necessary.
- B) Peel two to three inches of red vinyl backing away from edge trim tape. Applying the adhesive side of the edge trim to the inner side of the flare, affix the edge trim to the top edge of the flare (the portion that comes in contact with the vehicle). **See Illustration #1**
- C) Press edge trim into place along the top edge of the flare in one-foot increments, pulling red vinyl backing free as you continue to work your way around the top edge of the flare.

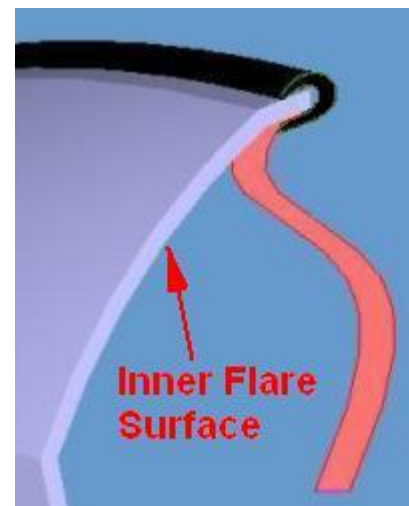

Illustration #1

Step 3: Attaching Front Flares (See Illustrations #2 & #3)

- A) When necessary, remove the screws used to hold the factory edge trim (and mud flap) along inside rim of the wheel well.
- B) Drill seven 5/16" holes at the indents located on the inside surface of the flare.
- C) Remove protective paper on one side of the double stick tabs. Press tabs onto inside of front and rear flare. **See Illustration #2.**
- D) Remove remaining protective paper from double stick tabs, and press flare ends into position on fender.
- E) Secure flares to fender using screws removed in Step 3A and kit supplied 3/4" screws. **See Illustrations #2 and #3.** Insert screws through flare and into plastic screw retainers along inside of wheel well rim. Secure mud flap (4WD) and lower rear portion of flare using the original 1" screws with wide washers.

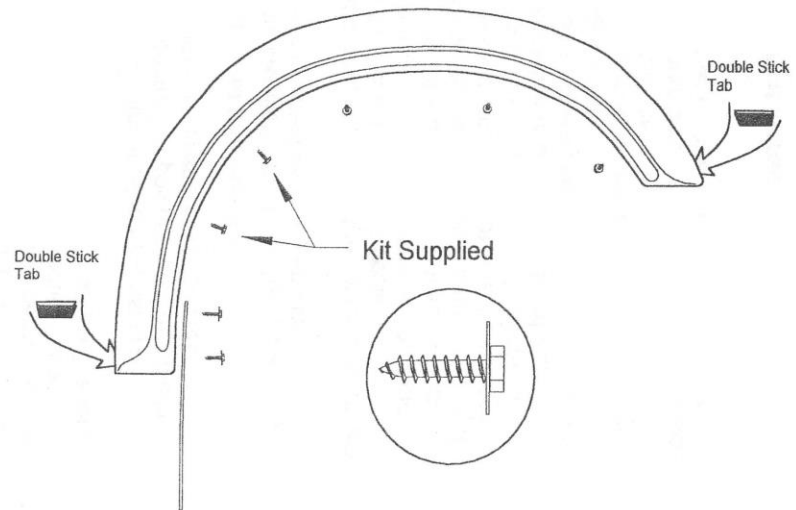

Illustration #2

Step 4: Attaching Rear Flares (See Illustration #4)

- A) On vehicles with factory edge trim and/or mud flaps, remove and save nuts, bolts, and screws used for installation.
- B) Drill seven 5/16" holes at the indents located on the inside surface of the flare.
- C) Remove protective paper on one side of the double stick tabs. Press tabs onto inside of front and rear flare "Flats". **See Illustration #4.**
- D) Remove remaining protective paper from double stick tabs, and press flare ends into position on fender.
- E) Secure flares to fender at plastic retainers using both the screws removed in Step 4A and the 3/4" screws supplied in the kit. **See Illustration #4.**
- F) For 4WD vehicles only, trim the upper-outside edge of factory mud flaps for proper fit.
- G) Re-secure mud flaps to bracket using metric wrench and the 3 nut and bolt sets removed in Step 4A.

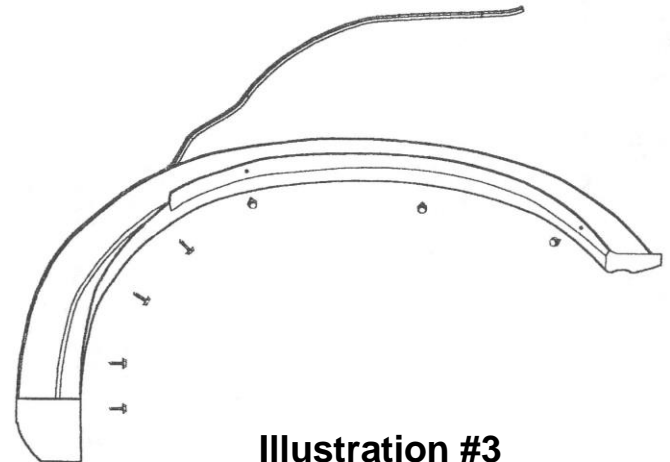

Illustration #3

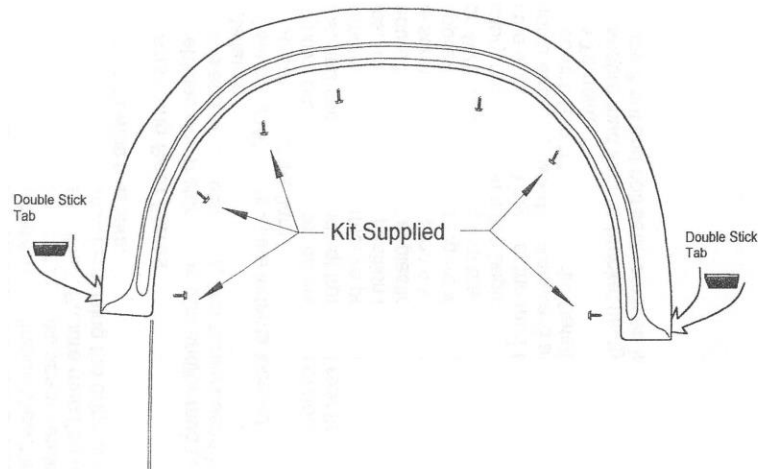

Illustration #4