



**IMPORTANT WARRANTY & INSTALLATION
INSTRUCTIONS ATTACHED**

*Please Forward All Attached Information to Consumer
Warranty Not Valid Unless Returned to CORSA Performance*

We ask that you take a few moments to complete our warranty registration form:

TO ACTIVATE YOUR LIMITED LIFETIME WARRANTY GO TO:
CORSAPERFORMANCE.COM/WARRANTY



**For Full-Color Installation Instructions, Please Visit:
CORSAPERFORMANCE.COM and Search by Part Number**

Please be sure to review the enclosed instructions prior to beginning the installation process. If you have any questions about the enclosed parts, instructions or encounter a problem during installation:
CALL CORSA PERFORMANCE TECHNICAL ASSISTANCE AT 800.486.0999

Please take the time to read and understand installation instructions.

CORSA[®] recommends that installation of this system be performed by a qualified service center or professional muffler installer who has the necessary equipment, tools and experienced personnel. However, if you decide to perform this install, the use of a hoist and an additional person will be required.

CAUTION: Never work on a hot exhaust system. Allow time for the vehicle to cool. Always wear eye protection when working under a vehicle.

Please confirm that all parts are present before beginning the factory exhaust system removal and CORSA exhaust system installation.

Bill of Materials:

1. Tunnel Muffler Assembly
 2. Rear Muffler Assembly
 3. Tip Assembly
 4. 3" Cat-Back Adapter
 5. Axle Pipe Assembly
 6. Hardware Kit
- Anti-Seize Lubricant Packet

Recommended Tools:

- Safety Glasses
- 13mm socket and ratchet
- 15mm socket
- Grommet pullers
- Soapy water solution
- Torque wrench
- Long extension
- Saw or chain style pipe cutter

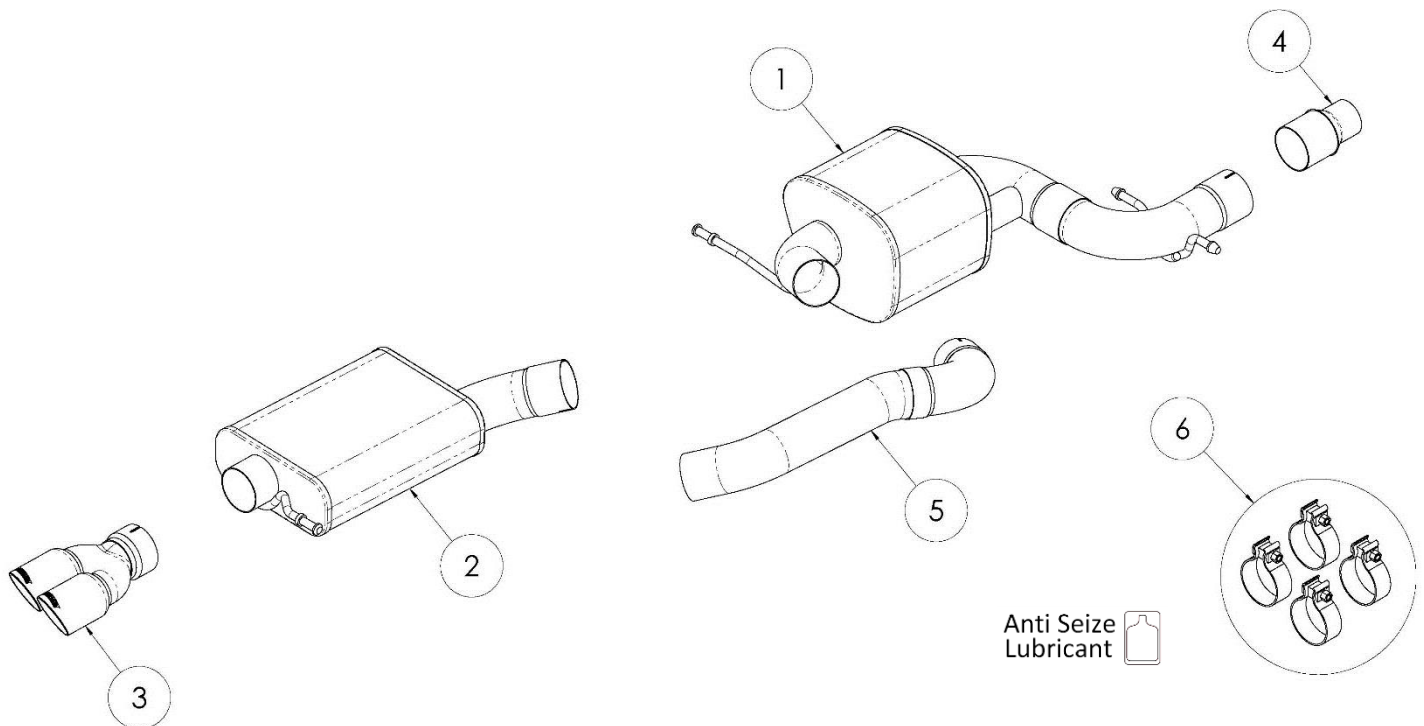

Removal of Stock System:

1. Measure from the outlet weld of the tunnel muffler and mark the axle pipe at 3 inches. **(SEE Fig. A)**
2. Using a saw or chain style pipe cutter, cut the axle pipe at the mark. This cut is necessary to enable the stock rear muffler section to be removed from over the suspension.
3. Unbolt the rear muffler hanger mount using a 13mm socket and a long extension. **(SEE Fig. B)** There are two bolts retaining the hanger mount. Next, carefully rotate and slide the factory rear section back and downwards to free it from the vehicle. **(SEE Fig. C)** With the rear muffler section on the ground, remove the factory rear muffler hanger from the rubber isolator on the hanger mount using a grommet puller or a similar device. Set aside both the rear muffler hanger mount and the retaining bolts to be reused during the installation process.

NOTE: The use of soapy water solution may aid in the removal and later installation of the hangers in the rubber isolators.

4. Carefully remove the factory rear tunnel brace. It is secured with four 13mm retaining nuts. **(SEE Fig. D)**
5. Using a 13mm socket and ratchet, loosen both nuts on the factory cat-back to downpipe clamp. **(SEE Fig. E)**
6. Using grommet pullers or a similar device, remove the grommets from the two front hangers near the front of the cat-back section. **(SEE Fig. F)**
7. Using grommet pullers or a similar device, remove the hanger from the grommet at the rear of the factory tunnel muffler. **(SEE Fig. G)** Carefully slide the factory tunnel section back from the clamping location to free it from the vehicle. This completes the removal process.



FIG A



FIG B



FIG C



FIG. D



FIG. E



FIG. F

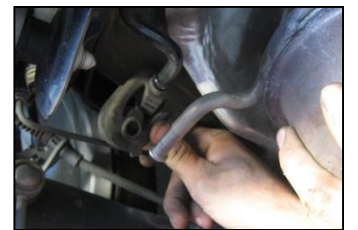

FIG. G

Installation of CORSA® Exhaust System:

NOTE: Apply the anti-seize lubricant (supplied) to the threads **ONLY** of all the clamps and flange bolts. Failure to follow this procedure can cause nuts to seize on clamps and potentially destroy threads. After applying anti-seize lubricant, be sure to thoroughly clean hands as lubricant will tarnish stainless steel.

Align all clamps so that the center of the clamp bolt is 90 degrees from the notch on the pipe (SEE Fig. A)

NOTE: All clamps should be tightened using a properly calibrated Torque Wrench. Using an air impact gun will damage the clamp and reduce its ability to effectively seal the joint. It may also cause the joint to separate thereby causing damage to your exhaust system and your vehicle.

1. Remove all exhaust system components from the shipping carton, including the four 3" clamps and the 3" Cat-Back adapter, which allows this system to be connected to the factory downpipe.

If connecting to the factory downpipe: Trim the rear of the factory downpipe to create space to fit in the 3" cat-back adapter. Reuse the factory downpipe to cat-back clamp to connect the small end of the adapter to the trimmed factory downpipe and tighten the clamp nuts with a 13mm socket and ratchet. Torque the clamp nuts to factory specs. The CORSA® tunnel muffler assembly will mount to the larger end of the 3" cat-back adapter and is secured with one of the 3" clamps included with this system.

If connecting to an aftermarket 3" downpipe: Do not use the 3" cat-back adapter. Your CORSA® system will mount directly to 3" diameter pipe. Note that additional fabrication may be necessary to adjust the length or position of any 3" downpipe (other than the CORSA® downpipe) being used to properly mount to this CORSA® cat-back system.

2. Reinstall the factory tunnel brace using the four retaining nuts and tighten using a 13mm socket and ratchet. Torque nuts to 18 ft-lbs (24 N-m). (SEE Fig. B)
3. Locate the CORSA axle pipe assembly. Carefully route the assembly through the tunnel above the rear suspension. (SEE Fig. C) Make sure the expanded end of the axle pipe section faces forward in the vehicle.

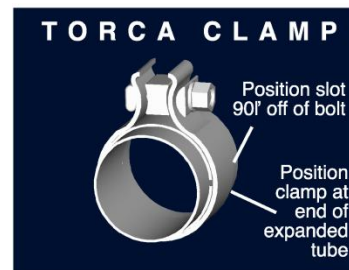

FIG A



FIG B



FIG C

CONTINUES ON NEXT PAGE



4. Locate the CORSA® tunnel muffler assembly and a 3" clamp. Properly align the clamp on the tunnel muffler inlet and slide it over the end of the lower downpipe assembly. Insert the hangers into the corresponding rubber grommets, starting with the two front hangers and then moving to the hanger just behind the tunnel muffler. **(SEE Fig. D & E)** A soapy water solution will aid in the installation process of the hangers. Snugly tighten the 3" clamp to retain the tunnel muffler section. **(SEE Fig. F)**
5. Locate another 3" clamp. Properly align the clamp on the axle pipe inlet and slide the axle pipe over the end of the tunnel muffler assembly. Adjust the amount of overlap at the clamp joint, and the orientation of the axle pipe so that it has approximately the same amount of clearance on the top side to the heat shield as it does on the bottom side to the suspension components. **(SEE Fig. G)** While holding the axle pipe in place, snugly tighten the 3" clamp to retain this section. **(SEE Fig. H)**
6. Locate the CORSA® rear muffler assembly, a 3" clamp, and the factory rear muffler hanger mount with its retaining bolts set aside in step 3 of the cat-back removal process. Insert the rear muffler hanger into the factory hanger mount. Make sure the mount is oriented as shown. **(SEE Fig. I)**

NOTE: The rear muffler installation is difficult to perform without any assistance due to only one hanger being present behind the rear suspension. We recommend having an assistant available to help position both the axle pipe and the rear muffler during this process.

7. Properly align the 3" clamp on the rear muffler inlet and slide the rear muffler over the end of the axle pipe assembly. Align the factory hanger mount with the mounting holes and secure with the two bolts retained from the removal process using a 13mm socket and ratchet. Torque to 18 ft-lbs (24 N-m). Verify that there is approximately the same amount of axle pipe clearance to both the heat shielding and the suspension where the pipe exits. **(SEE Fig. J)**

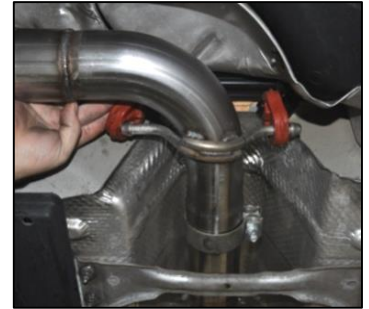

FIG D



FIG E



FIG F



FIG. G



FIG. H



FIG. I



FIG. J

CONTINUES ON NEXT PAGE



8. Locate the CORSA[®] tip assembly and the last 3" clamp. Properly align the clamp on inlet of tip assembly and slide onto rear muffler assembly. Snugly tighten clamp to retain tip assembly. **(SEE Fig. K)**
9. Adjust the amount of overlap at the clamp joint between the rear muffler assembly and the axle pipe, and the position and rotation of the rear muffler assembly until the gap between the tips and the rear bumper cover looks even all around. **(SEE Fig. L)** While holding the both the rear muffler and axle pipe in place, snugly tighten the 3" clamp to retain the rear muffler section. **(SEE Fig. M)** Adjust the depth and rotation of tip assembly. Addition adjustment at either end of the axle pipe may be necessary to Optimize both the pipe clearance through the suspension and the rear muffler position.
10. Visually inspect the exhaust system position, tip alignment, clamp orientation, and exhaust pipe clearance. Make any necessary adjustments at the slip joints.
11. When the exhaust system is in the desired location, tighten the nuts on the clamps. Torque nuts to 45 ft-lbs (61 N-m). This completes the installation of the CORSA[®] system.
12. It is **STRONGLY SUGGESTED** that all clamps be checked and re-tightened (if necessary) to the recommended torque after initial road testing of the vehicle, as thermal cycling has occurred on the system. Please wait until the system has fully cooled to perform this step.



FIG. K



FIG. L

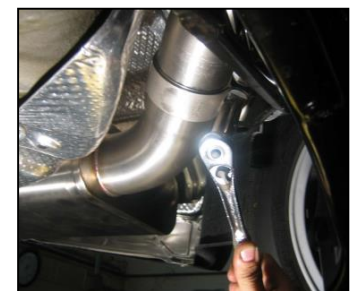

FIG. M

NOTE: During cold weather start-ups, you may experience an exhaust sound that is deeper and louder in tone than usual. This is temporary and will diminish to normal levels once your engine has reached its normal operating temperature.

NOTE: Immediately following the installation of your exhaust system, you may experience a trace of smoke after initial start-up. DO NOT be alarmed. The smoke is caused by the burning of a small amount of forming oil residue used in the manufacturing process.

FOR TECHNICAL ASSISTANCE CALL: (800) 486-0999