



IMPORTANT WARRANTY & INSTALLATION
INSTRUCTIONS ATTACHED

*Please Forward All Attached Information to Consumer
Warranty Not Valid Unless Returned to CORSA Performance*

We ask that you take a few moments to complete our warranty registration form:

TO ACTIVATE YOUR LIMITED LIFETIME WARRANTY GO TO:
CORSAPERFORMANCE.COM/WARRANTY



**For Full-Color Installation Instructions, Please Visit:
CORSAPERFORMANCE.COM and Search by Part Number**

Please be sure to review the enclosed instructions prior to beginning the installation process. If you have any questions about the enclosed parts, instructions or encounter a problem during installation:

CALL CORSA PERFORMANCE TECHNICAL ASSISTANCE AT 800.486.0999

Please take the time to read and understand installation instructions.

CORSA[®] Performance recommends that installation of this system be performed by a qualified service center or professional muffler installer who has the necessary equipment, tools and experienced personnel. However, if you decide to perform this install, the use of a hoist and an additional person will be required.

CAUTION: Never work on a hot exhaust system. Allow time for the vehicle to cool. Always wear eye protection when working under a vehicle.

Please confirm that all parts are present before beginning the factory exhaust system removal and CORSA[®] Performance exhaust system installation.

Bill of Materials:

1. Lower Downpipe Assembly
 2. 3" Downpipe Adapter
 3. Upper Downpipe Assembly
 4. Hardware Kit
- Anti-Seize Lubricant Packet

Recommended Tools:

- Safety Glasses
- 13mm socket and ratchet
- 15mm socket
- 16mm socket
- Penetrating lubricant
- 1" Socket
- Torque Wrench
- 22mm Oxygen Sensor Wrench
- Locking Style Pliers

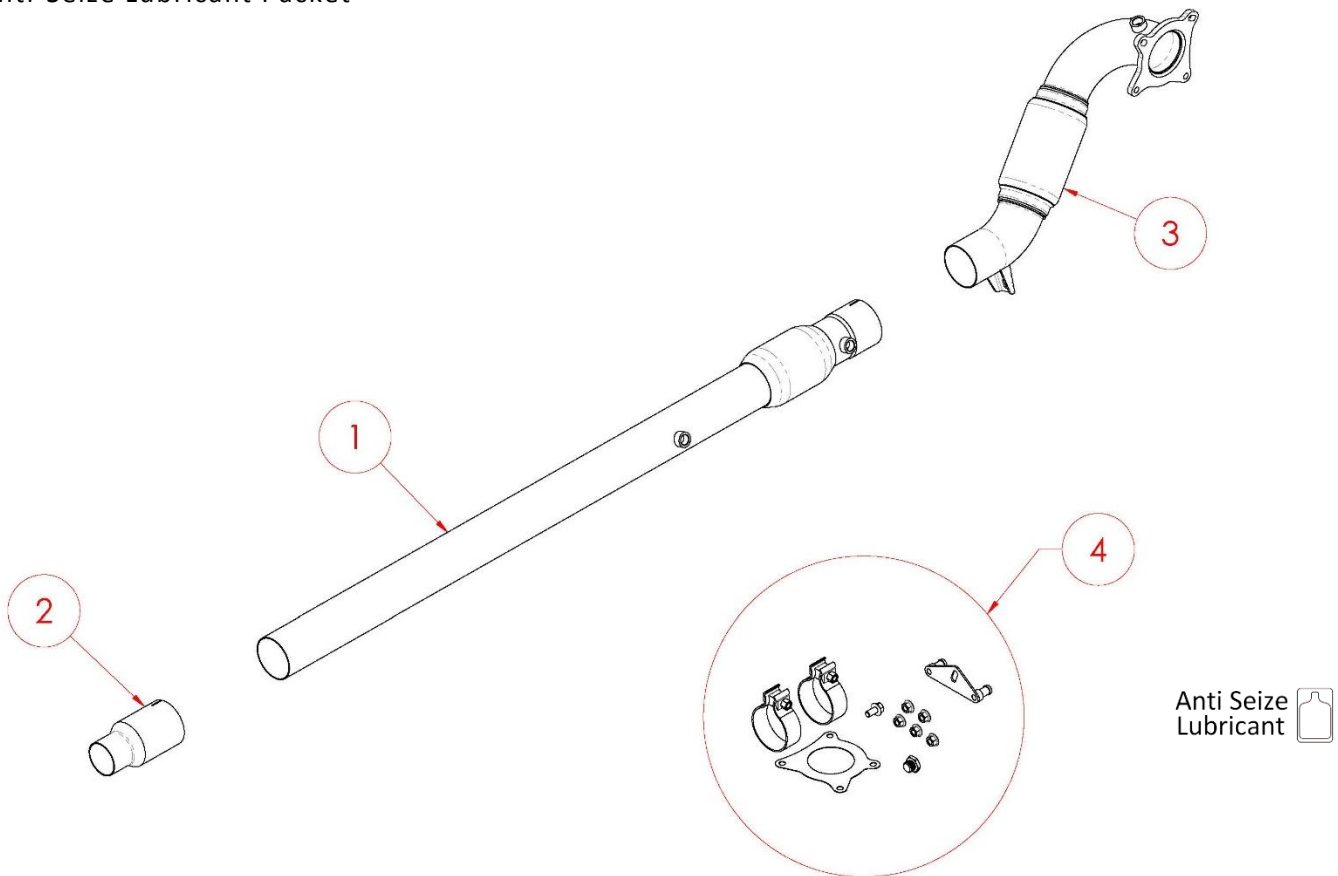

Removal of Stock System:

The factory downpipe will be removed in two steps: (1) Disconnect and then lower the stock cat-back (rear) section. (2) Remove the downpipe (front) section.

Cat-Back Section:

If a factory cat-back system is on the vehicle:

1. Using a 13mm wrench, loosen both nuts on each of the factory cat-back to downpipe sleeve clamps. (See Fig. A)
2. Using grommet pullers or a similar device, remove the grommets from the two front hangers near the front of the cat-back section. (See Fig. B)

NOTE: The use of a soapy water solution may aid in the removal and later installation of the hangers in the rubber isolators.

3. Slide the factory clamp off of the cat-back section, and allow the front side of the cat-back to hang down, making sure it clears the downpipe
4. Remove the cat back to downpipe clamp from the downpipe, and set it to the side. This clamp will be reused to connect the 3" CORSA[®] Performance adapter to the factory cat-back system.

If an aftermarket 3" cat-back is on the vehicle:

Remove the clamp securing the system to the stock downpipe and then follow steps 2 & 3 above to let it hang down out of the way of the downpipe. Note that any 3" cat-back that necks down to the stock downpipe size will have to be modified (i.e. Trim off the smaller section and then have a 3" expanded sections welded on) to allow it to properly fit up to your CORSA[®] Performance downpipe.

Downpipe Section:

1. Open the hood and disconnect the negative terminal from the battery.

NOTE: If you have the FSI (BPY) version of the vehicle, follow steps 2-5, then skip to step 9. If you have the TSI (CCTA & CBFA) version of the vehicle, skip to step 6.

2. Disconnect the MAF sensor plug near the top passenger side of the engine shroud and remove the wire from the clip holding it to the shroud. (See Fig. C) Unclip the turbo intake pipe from the engine shroud and separate the two pieces, being careful not to lose the O-ring gasket that is used to seal this connection (See fig D & E)

CONTINUED ON NEXT PAGE 

- Using a pair of Locking Pliers (ie. Channel Locks) or a similar device, unclip the air snorkel from the engine shroud. **(See Fig. F)** Move the snorkel clear of the connection to free the engine shroud. **(See Fig. G)**
- Remove the engine shroud from the engine by pulling upwards to free it from the four retaining studs. **(See Fig. H)**
- Unplug the upper downpipe oxygen sensor connector near the brake master cylinder on the driver side of the vehicle and remove the wire from the clip anchoring it to the firewall. **(See Fig. I)**

For the TSI version:

- Disconnect the MAF sensor plug near the top driver side of the engine shroud and remove the wire from the clip holding it to the flexible air tuber. **(See Fig. J)**
- Using a pair of Locking Pliers (ie. Channel Lock) or a similar device, unclip the flexible air tube from the solid turbo inlet pipe. **(See Fig. K)** Move the flexible tube clear of the connection. Next, unclip the other end of the flexible air tube from the MAF sensor housing. **(See Fig L)** Remove the flexible tube from the vehicle.
- Unplug the upper downpipe oxygen sensor connector near the brake master cylinder on the driver's side of the vehicle and remove the wire from the clip anchoring it to the firewall. **(See Fig. M & N)** This step will not be necessary in TSI (CBFA) versions of the vehicle.

NOTE: If you have the FSI (BPY) or TSI (CCTA) version of the vehicle, follow step 9. If you have the TSI (CBFA) version of the vehicle, skip to step 10, as the upper oxygen sensor will be located on the turbo housing and will not need to be removed during the install process.

- Using a 22mm oxygen sensor wrench, remove the upper downpipe oxygen sensor from the factory downpipe. **(See Fig. O)** **NOTE:** Breaking the sensor loose from the factory downpipe may be easier from the underside of the vehicle, especially on the TSI (CCTA) version.

WARNING: Be careful to not contaminate the sensor end of the oxygen sensors with dirt, grease, etc. as it may prevent them from functioning properly.

- Spray the downpipe flange mounting nuts with a penetrating lubricant. Allow product to soak in per product recommendations. Then remove the two upper downpipe flange nuts using a 16mm socket and ratchet. **(See Fig P)**
- Remove the CV Shaft heat shield from the rear of the engine using a 16mm socket and ratchet. **(See Fig. Q)** Remove the two lower downpipe flange nuts using a 16mm socket and ratchet. **(See Fig. R)**

CONTINUED ON NEXT PAGE 

12. Use the 22mm oxygen sensor wrench to remove the lower oxygen sensor from the downpipe. This sensor is located in the tunnel underneath the vehicle and is downstream of the last factory catalytic converter. **(See Fig. S)**

NOTE: If you have the TSI (CBFA) version of the vehicle, follow step 13. If you have the FSI (BPY) or TSI (CCTA) version of the vehicle, skip to step 14, as the additional oxygen sensor upstream of the last factory catalytic converter will not be present.

13. Use the 22mm oxygen sensor wrench to remove the second lower oxygen sensor from the downpipe. This sensor is also located in the tunnel underneath the vehicle and is upstream of the last factory catalytic converter. **(See Fig. T)**

14. Unbolt the downpipe grommet bracket from the vehicle by removing the two bolts with a 13mm socket and ratchet. **(See Fig. U)**

15. Carefully remove the two tunnel braces. Each brace is secured with four 13mm nuts. **(See Fig. V)** The downpipe section will most likely droop when the last brace is removed.

16. Remove the downpipe from the vehicle by sliding the mounting flange off of the studs coming from the turbo. Remove the downpipe grommet bracket from the factory downpipe hangers. This completes the removal of the downpipe section.

REMOVAL PHOTOS ON NEXT PAGE



Removal Pictures

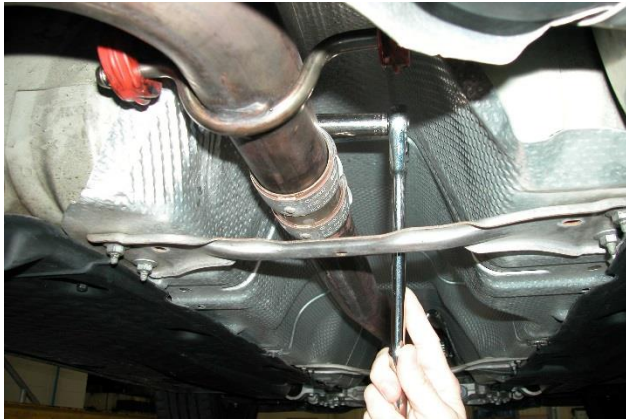

Fig. A

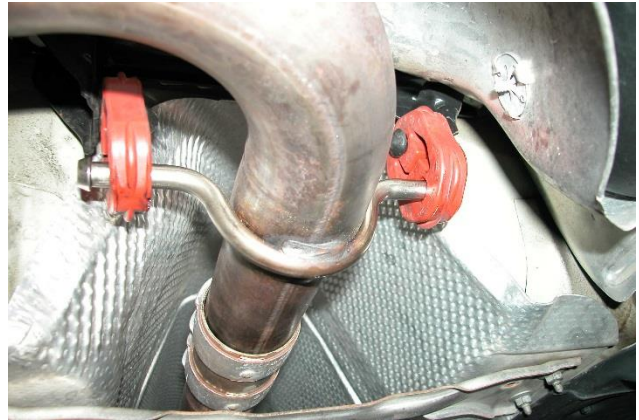

Fig. B



Fig. C



Fig. D



Fig. E



Fig. F

CONTINUED ON NEXT PAGE 

Removal Pictures



Fig. G



Fig. H



Fig. I



Fig. J



Fig. K



Fig. L

CONTINUED ON NEXT PAGE 

Removal Pictures



Fig. M



Fig. N

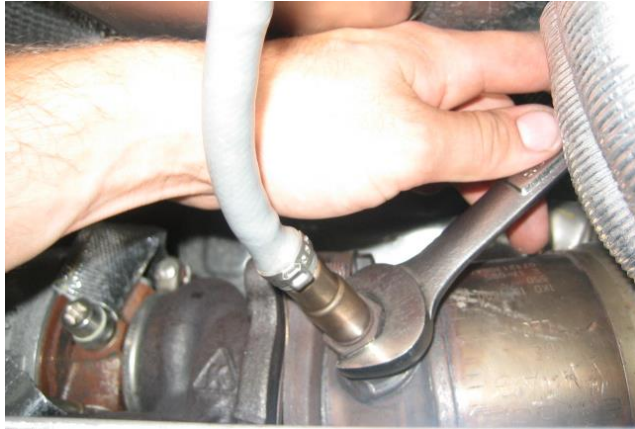

Fig. O



Fig. P



Fig. Q



Fig. R

CONTINUED ON NEXT PAGE 

Removal Pictures

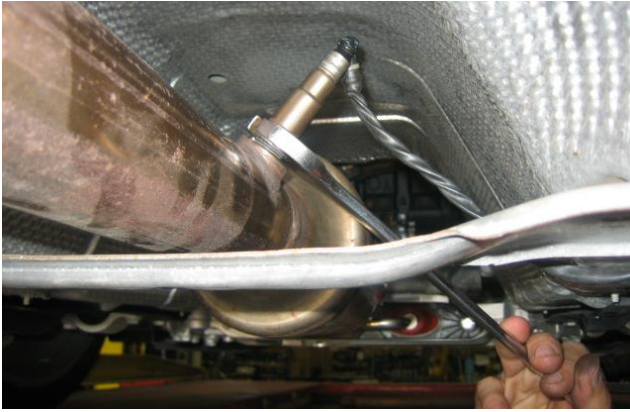

Fig. S

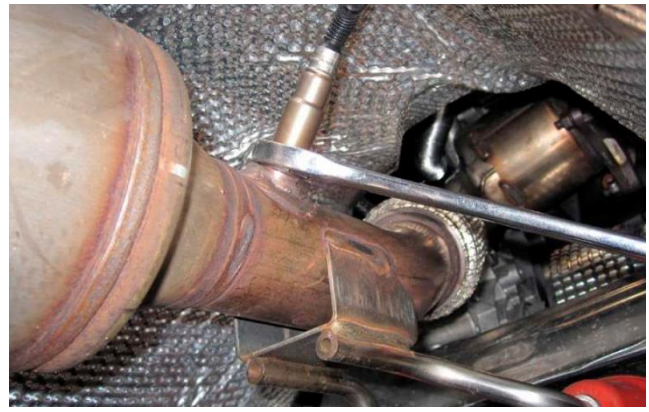

Fig. T



Fig. U



Fig. V

Installation of CORSA[®] Performance Exhaust System:

NOTE: Apply the anti-seize lubricant (supplied) to the threads **ONLY** of all the clamps and flange bolts. Failure to follow this procedure can cause nuts to seize on clamps and potentially destroy threads. After applying anti-seize lubricant; be sure to thoroughly clean hands as lubricant will tarnish stainless steel.

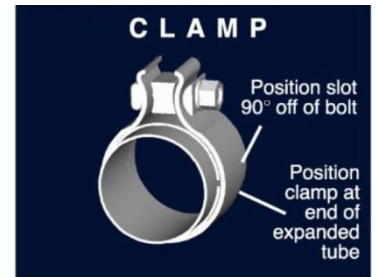

NOTE: Align all clamps so that the center of the clamp bolt is 90 degrees from the notch on the pipe (See Fig. CLAMP)

All clamps should be tightened using a properly calibrated Torque Wrench. Using an air impact gun will damage the clamp and reduce its ability to effectively seal the joint. It may also cause the joint to separate thereby causing damage to your exhaust system and your vehicle.

1. Remove all exhaust system components from the shipping carton, including the two 3.0" clamps, the five M10 flange nuts, the M10 flange bolt, the M18 oxygen sensor port block off bolt, the downpipe flange gasket, and the 3" downpipe adapter.
2. Locate the CORSA[®] Performance upper downpipe assembly, four of the M10 flange nuts and the downpipe flange gasket. Place the new OEM downpipe flange gasket over the studs coming out of the turbo. **(See Fig. B)** Then slide the mounting flange of the Upper downpipe assembly over the mounting studs. Hand thread on the four M10 flange nuts. Tighten the two lower downpipe flange mounting nuts using a 15mm socket and ratchet. **(See Fig. C)**
3. Tighten the two upper downpipe flange mounting nuts with the 15mm socket and ratchet. **(See Fig. D)** Torque all flange mounting nuts to 22ft-lbs (30N-m)

NOTE: If you have the FSI (BPY) or TSI (CCTA) version of the vehicle, follow step 4, then skip to step 6. If you have the TSI (CBFA) version of the vehicle, skip to step 5, as the upper oxygen sensor position on the downpipe will not be utilized.

4. Install the upper downpipe oxygen sensor and tighten with the 22mm oxygen sensor wrench. **(See Fig. E)** Reconnect oxygen sensor connector to the plug near the brake master cylinder and anchor the wire with the retaining clip on the firewall. **(See fig. F)**
5. Install the M18 oxygen sensor port block off bolt into the same mounting position that is shown in Figure E using a 1" socket and ratchet.

NOTE: If you have the FSI (BPY) version of the vehicle, follow steps 6-7, then skip to step 10. If you have the TSI (CCTA) version of the vehicle, skip to step 8.

CONTINUED ON NEXT PAGE



For the FSI Version:

6. Install the engine shroud by aligning it with the mounting studs and pushing it firmly onto the engine. Align and fasten the turbo intake pipe to the top passenger side of the engine shroud, making sure that the O-ring gasket is in place and properly positioned. **(See Fig. G)** Plug in the adjacent MAF sensor plug and anchor the sensor wire to the engine shroud. **(See Fig. H).**
7. Align the air snorkel with the mating inlet to the engine shroud. Using a pair of Channel Lock Pliers or a similar device, install the retaining clip for the air snorkel. **(See Fig. I)**

For the TSI Version:

8. Align the flexible air tube with the MAF sensor housing. Using a pair of Channel Lock Pliers or a similar device, install the retaining clip for the flexible tube. **(See Fig. J)** Align the other end of the flexible air tube to the solid turbo inlet pipe and install the other retaining clip. **(See Fig. K)**
9. Plug in the adjacent MAF sensor plug and anchor the sensor wire to the flexible air tube. **(See Fig. L)**
10. Use the 16mm socket and ratchet to mount the CV shaft heat shield to the rear of the engine. Tighten to 22 ft-lbs (30 N-m). **(See Fig. M)** Bolt the downpipe grommet bracket to the vehicle with a 13mm socket and ratchet. Make sure the bracket is oriented as shown. **(See Fig. N)** tighten bolts to 18 ft-lbs (24 N-m)
11. Locate the CORSA[®] Performance hanger assembly, the remaining M10 flange nut and the M10 x 20mm long bolt. Push the hanger assembly studs into the grommet bracket from step 10, with the center hole aligned with the slotted hole on the upper downpipe mounting tab. Install the M10 bolt through these holes from the engine side and secure with the M10 flange nut. Snugly tighten with a 15mm socket and ratchet. **(See Fig. O)**
12. Locate the lower downpipe assembly and one of the 3" clamps. Properly align the clamp (see above note) on the catalytic converter side of the lower downpipe and slide the lower downpipe inlet over the end of the upper downpipe assembly. **(See fig. P)** Check the orientation of the lower downpipe so that the oxygen sensor bungs are oriented upward and towards the passenger side of the vehicle. Snugly tighten the 3" clamp to retain the lower downpipe section. **(See fig. Q)**
13. Install the downpipe oxygen sensor in the corresponding bung behind the catalytic converter and tighten using the 22mm oxygen sensor wrench. **(See Fig. R)** Rotate the lower downpipe assembly (if necessary) to make sure the oxygen sensor wire has some slack in it to prevent damage.

CONTINUED ON NEXT PAGE 

NOTE: If you have the TSI (CBFA) version of the vehicle, follow step 14, then skip to the connection options after step 15. If you have the FSI (BPY) or TSI (CCTA) version of the vehicle, skip to step 15, as the additional oxygen sensor position upstream of the catalytic converter will not be utilized.

14. Install the downpipe oxygen sensor in the corresponding bung in front of the catalytic converter and tighten using the 22mm oxygen sensor wrench. (See Fig. S).
15. Install the M18 oxygen sensor port block off bolt into the same mounting position that is shown in Figure S using a 1" socket and ratchet.

If connecting to the factory cat-back: trim the rear of the 3" CORSA[®] Performance downpipe to create space to fit in the 3" downpipe adapter. The CORSA[®] Performance downpipe will mount to the larger end of the 3" downpipe adapter and is secured with one of the 3" clamps included with this system. Snugly tighten the 3" clamp to retain the adapter. Reuse the factory downpipe to cat-back clamp to connect the small end of the adapter to the factory cat-back system and tighten the clamp to connect the small end of the adapter to the factory cat-back system and tighten the clamp nuts with a 13mm socket and ratchet. Torque the clamp nuts to factory specs.

If connecting to an aftermarket 3" cat-back: do not use the 3" downpipe adapter. Your CORSA[®] Performance system will mount directly to pipe that has a 3" expanded section. The expansion allows the connecting pipe to fit over the 3" diameter downpipe. Note that additional fabrication may be necessary to adjust the length, size, or position for any 3" cat-back (Other than the CORSA[®] Performance cat-back) being used to properly mount to this CORSA[®] Performance downpipe.

16. Install the two factory tunnel braces using the four retaining nuts for each brace and tighten using a 13mm socket and ratchet. Torque nuts to 18 ft-lbs (24 N-m). (See Fig. T)
17. Insert the two front hangers into the corresponding rubber grommets. (See fig. U) A soapy water solution will aid in the installation process of the hangers.
18. Visually inspect the exhaust system position, tip alignment, clamp orientation and exhaust pipe clearance. Make any necessary adjustments at the two slip joints and at the front downpipe hanger assembly.
19. When the exhaust system is in the desired location, tighten the nuts on the clamps. Torque nuts to 45 ft-lbs (61 N-m). Tighten the M10 nut and bolt at the front downpipe hanger assembly to 22 ft-lbs (30 N-m).
20. Reconnect the negative battery terminal. Let the car sit for at least three minutes with the ignition key on and the engine off. Close the hood. Installation complete.

CONTINUED ON NEXT PAGE 

21. It is **STRONGLY SUGGESTED** that all clamps be checked and re-tightened (if necessary) to the recommended torque after initial road testing of the vehicle, as thermal cycling has occurred on the system. Please wait until the system has fully cooled to perform this step.

NOTE: During cold weather start-ups, you may experience an exhaust sound that is deeper and louder in tone than usual. This is temporary and will diminish to normal levels once your engine has reached its normal operating temperature.

NOTE: Immediately following the installation of your exhaust system, you may experience a trace of smoke after initial start-up. **DO NOT** be alarmed. The smoke is caused by the burning of a small amount of forming oil residue used in the manufacturing process.

INSTALLATION PHOTOS ON NEXT PAGE 

Installation Pictures

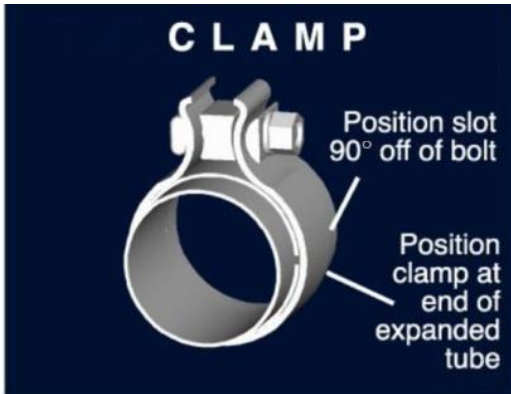

Fig. CLAMP



Fig. B

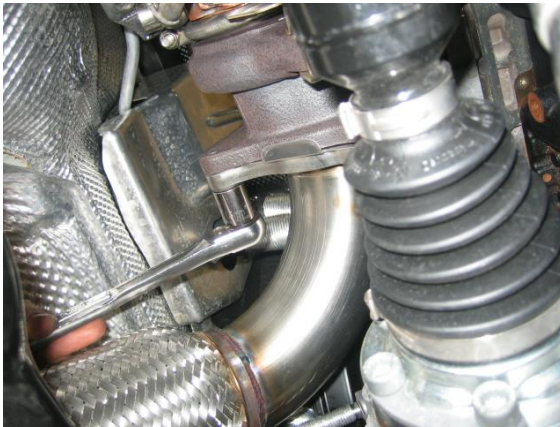

Fig. C



Fig. D



Fig. E



Fig. F

CONTINUED ON NEXT PAGE 

Removal Pictures



Fig. G



Fig. H



Fig. I



Fig. J



Fig. K



Fig. L

CONTINUED ON NEXT PAGE 

Removal Pictures



Fig. M



Fig. N



Fig. O



Fig. P



Fig. Q

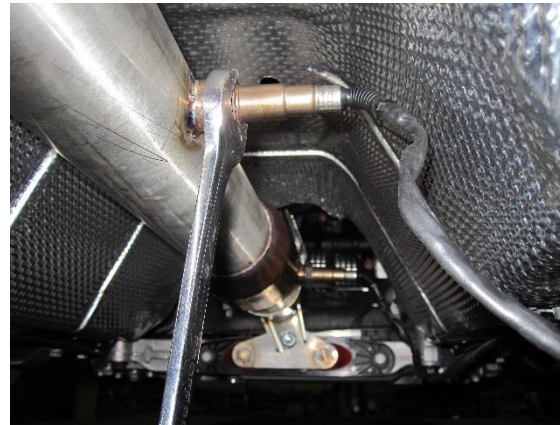

Fig. R

CONTINUED ON NEXT PAGE 

Removal Pictures

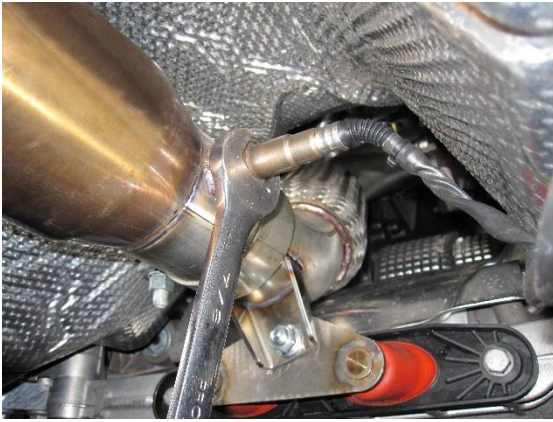

Fig. S



Fig. T



Fig. U