

**11012****1994-1998 MITSUBISHI GALANT SEDAN**

12/10/2012

GROSS LOAD CAPACITY WHEN USED AS A WEIGHT CARRYING HITCH: 2,000 LBS. TRAILER WEIGHT &amp; 200 LBS. TONGUE WEIGHT.

**\*\*\*DO NOT EXCEED VEHICLE MANUFACTURER'S RECOMMENDED TOWING CAPACITY.\*\*\*****WARNING: ALL NON-TRAILER LOADS APPLIED TO THIS PRODUCT MUST BE SUPPORTED BY AUXILIARY STABILIZING STRAPS.****\*\* FAILURE TO PROPERLY SUPPORT NON-TRAILER LOADS WILL VOID PRODUCT WARRANTY\*\***

HAVING INSTALLATION QUESTIONS? CALL TECHNICAL SUPPORT AT 1-877-287-8634

Parts List			
ITEM	QTY	PART NUMBER	DESCRIPTION
1	2	7_16-14 TAB NUT	HANDLE NUT
2	4	3/8 - 16 x 1 1/4	HEX BOLT
3	4	3/8"	LOCK WASHER
4	4	3/8 - 16	HEX NUT
5	2	7/16 LOCK WASHER	HELICAL LOCK WASHER
6	2	7/16 - 14 x 3"	Hex Bolt
7	1	CM-11012-TB	.25 x 2.00 TAIL BRACKET

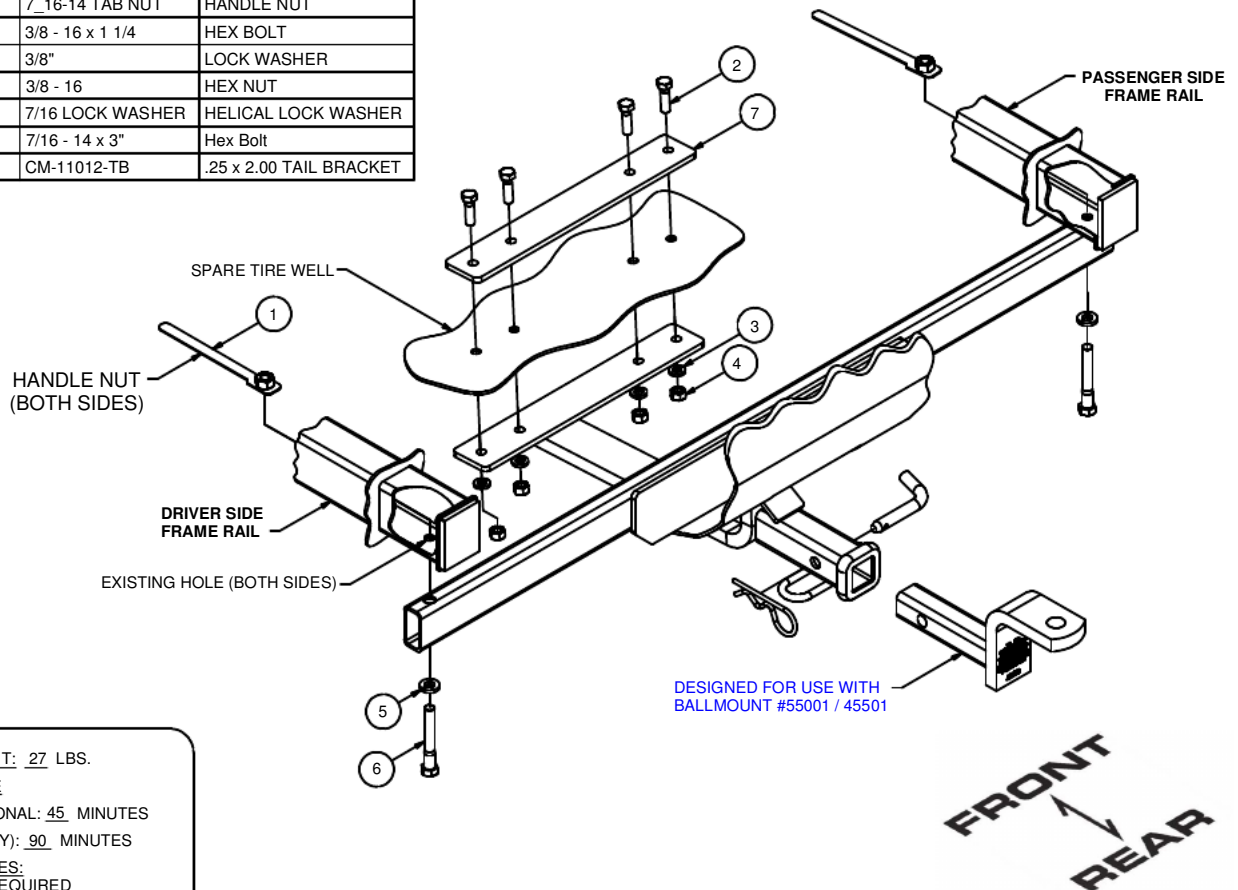
HITCH WEIGHT: 27 LBS.**INSTALL TIME**PROFESSIONAL: 45 MINUTESNOVICE (DIY): 90 MINUTES**INSTALL NOTES:**

- DRILLING REQUIRED

**INSTALLATION STEPS**

1. This hitch bolts into the bumper supports at the rearmost part of the frame and to the bottom (outside) of the spare tire well.
2. Before the hitch can be fitted, temporarily remove (2) fascia fasteners from under the car and (3) plastic fasteners inside the bumper holding the fascia to the bumper. Remove a 2" wide by 3" long section of the fascia, including a metal reinforcement.
3. Insert handle nuts into bumper beam support as shown.
4. Lift the hitch into position and align holes in hitch with holes where handle nuts were inserted in Step 3. Secure the hitch to the vehicle using the lock washers and hex bolts provided.
5. Check the hitch for square and level. Using the hitch as your template, drill (4) holes into the spare tire well as shown. Install the backing plate inside the tire well and secure with hardware as shown.
6. Torque all 7/16" hardware to 70 ft-lbs. Torque all 3/8" hardware to 45 ft-lbs.

**PERIODICALLY CHECK THIS RECEIVER HITCH TO ENSURE THAT ALL FASTENERS ARE TIGHT AND THAT ALL STRUCTURAL COMPONENTS ARE SOUND.**

Curt Manufacturing Inc., warrants this product to be free of defects in material and/or workmanship at the time of retail purchase by the original purchaser. If the product is found to be defective, Curt Manufacturing Inc., may repair or replace the product, at their option, when the product is returned, prepaid, with proof of purchase. Alteration to, misuse of, or improper installation of this product voids the warranty. Curt Manufacturing Inc.'s liability is limited to repair or replacement of products found to be defective, and specifically excludes liability for incidental or consequential loss or damage.