

11105

91-97 FORD ESCORT SEDAN & WAGON, 98-01 FORD ESCORT SEDAN, 91-00 MERCURY TRACER, 98-02 FORD ESCORT ZX2

12/30/2020

GROSS LOAD CAPACITY WHEN USED AS A WEIGHT CARRYING HITCH: 2,000 LBS. TRAILER WEIGHT & 200 LBS. TONGUE WEIGHT.

*****DO NOT EXCEED VEHICLE MANUFACTURER'S RECOMMENDED TOWING CAPACITY.*****

WARNING: ALL NON-TRAILER LOADS APPLIED TO THIS PRODUCT MUST BE SUPPORTED BY AUXILIARY STABILIZING STRAPS.

**** FAILURE TO PROPERLY SUPPORT NON-TRAILER LOADS WILL VOID PRODUCT WARRANTY****

HAVING INSTALLATION QUESTIONS? CALL TECHNICAL SUPPORT AT 1-877-287-8634

Parts List			
ITEM	QTY	PART NUMBER	DESCRIPTION
1	2	20-00174	NUT, HANDLE, 1/2-13 UNC, GRD8, CZ
2	2	20-00179	NUT, HEX, 9/16-12 UNC, GRD8, YZ
3	2	30-00194	WASHER, LOCK, 9/16, YZ
4	2	10-10500	HHCS, 9/16-12 UNC, 2, GRD8, YZ
5	4	CM-SP8	.188 x 1.25 x 1.50" ROUND HOLE SPACER
6	2	30-00153	WASHER, LOCK, 1/2, YZ
7	2	10-10470	HHCS, 1/2-13 UNC, 1-1/4, GRD8, YZ
8	2	30-00200	WASHER, FLAT, 9/16, YZ

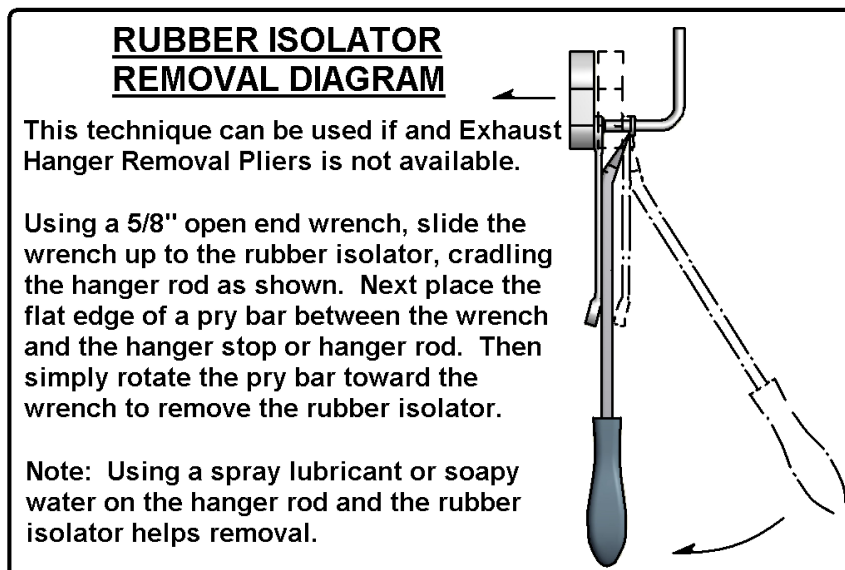

TRIM LIP AS NEEDED

POSITION OUTSIDE OF EXISTING TOW HOOK

LIP TRIM DIAGRAM

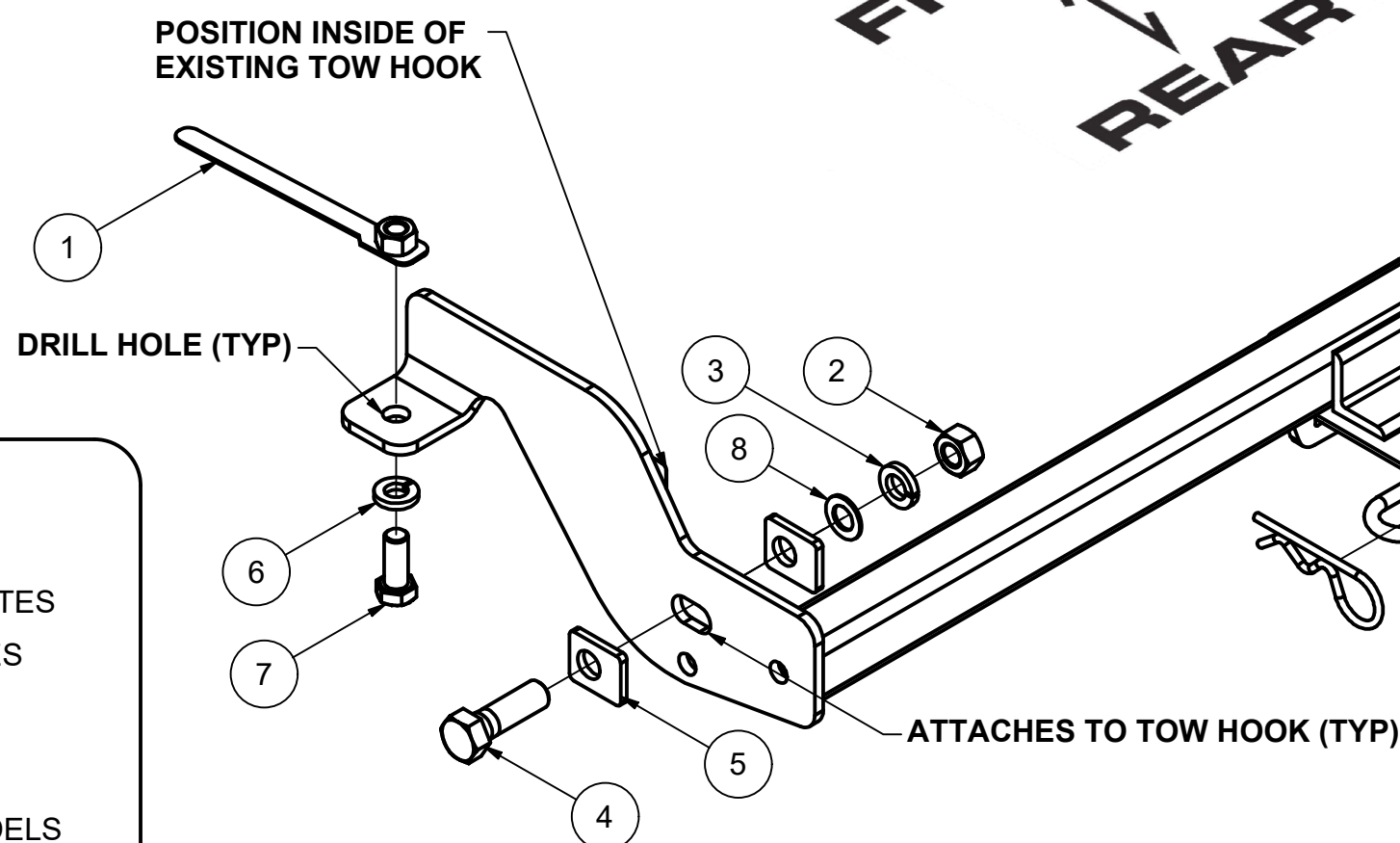
FRONT
↑
REAR

HITCH WEIGHT: 27 LBS.

INSTALL TIME

PROFESSIONAL: 45 MINUTES

NOVICE (DIY): 90 MINUTES

INSTALL NOTES:

- LOWER EXHAUST
- TRIMMING OF METAL LIP REQUIRED ON SOME MODELS

INSTALLATION STEPS

- 1.) Slide the two (2) rubber exhaust hangers off the exhaust hanger hooks.
- 2.) Lower the exhaust heat shield to locate access hole in frame rail. Remove the tape covering the access hole and enlarge them to provide access for handle nut.
- 3.) Remove the bolt retaining the carbon canister hoses on the drivers side frame rail.
- 4.) Raise hitch into position and loosely install the rearmost fasteners. The drivers side mounting plate should be positioned inside of tow hook and the passenger side mounting plate is positioned outside of the tow hook. Trim lip (if present) so that hitch can be raised into position. (See lip trim diagram)
- 5.) Using the hitch as a template, drill a 1/2" hole in each frame rail.
Note: The existing access hole may need to be enlarged for installation of the handle nut. Determine the distance between the installation hole and the access hole. Mark this distance on the handle nut and bend it to 90 degrees.
- 6.) Install the remaining fasteners and reattach the exhaust hangers, exhaust heat shield, and carbon canister hoses.
- 7.) Torque all 1/2" hardware to 110 lb/ft. and all 9/16" hardware to 150 lb/ft.

PERIODICALLY CHECK THIS RECEIVER HITCH TO ENSURE THAT ALL FASTENERS ARE TIGHT AND THAT ALL STRUCTURAL COMPONENTS ARE SOUND.

Curt Manufacturing Inc., warrants this product to be free of defects in material and/or workmanship at the time of retail purchase by the original purchaser. If the product is found to be defective, Curt Manufacturing Inc., may repair or replace the product, at their option, when the product is returned, prepaid, with proof of purchase. Alteration to, misuse of, or improper installation of this product voids the warranty. Curt Manufacturing Inc.'s liability is limited to repair or replacement of products found to be defective, and specifically excludes liability for incidental or consequential loss or damage.