

YEARS: 2011-2013
2014-CURRENT

MAKE: INFINITI

MODEL: M37X, M56X
Q70

STYLE: SEDAN

WARNING: NEVER EXCEED YOUR VEHICLE MANUFACTURER'S RECOMMENDED TOWING CAPACITY
For more information log onto www.curtmfg.com & for helpful towing tips log onto www.hitchinfo.com

WEIGHT CARRYING:
TRAILER WEIGHT: 2,000 LBS.
TONGUE WEIGHT: 200 LBS.

WARNING:
ALL NON-TRAILER (WHEEL-LESS) LOADS APPLIED TO THIS PRODUCT MUST BE SUPPORTED BY 18050 STABILIZING STRAPS. PLEASE SEE THE CURT CATALOG OR VISIT US ONLINE AT WWW.CURTMFG.COM FOR FURTHER INFORMATION.

PRO INSTALL TIME: 90 MIN.
NOVICE INSTALL TIME: 180 MIN.

IF YOU ARE HESITANT TO UNDERTAKE THIS TASK ON YOUR OWN, CONTACT AN AUTHORIZED CURT INSTALLER FOR ADDITIONAL ASSISTANCE.

INSTALLATION REQUIRES:

	10mm 12mm	
PHILLIPS & FLAT HEAD SCREW DRIVER	SOCKET	RATCHET
TORQUE WRENCH	ROTARY TOOL	MARKER

INSTALLATION TIPS:

- BEFORE YOU BEGIN INSTALLATION, READ ALL INSTRUCTIONS THOROUGHLY.
- TO EASE INSTALLATION, 2 PEOPLE MAY BE REQUIRED.
- USING PROPER TOOLS WILL GREATLY IMPROVE THE QUALITY OF THE INSTALL AND REDUCE THE TIME REQUIRED.
- NEED HELP OR HAVE SOME QUESTIONS? CALL TECHNICAL SUPPORT AT 877.287.8634

LEVEL OF DIFFICULTY: CHALLENGING

EASY	MODERATE	CHALLENGING
	TRIM UNDERBODY PANEL	
	REMOVE BUMPER	
	NO DRILLING REQUIRED	

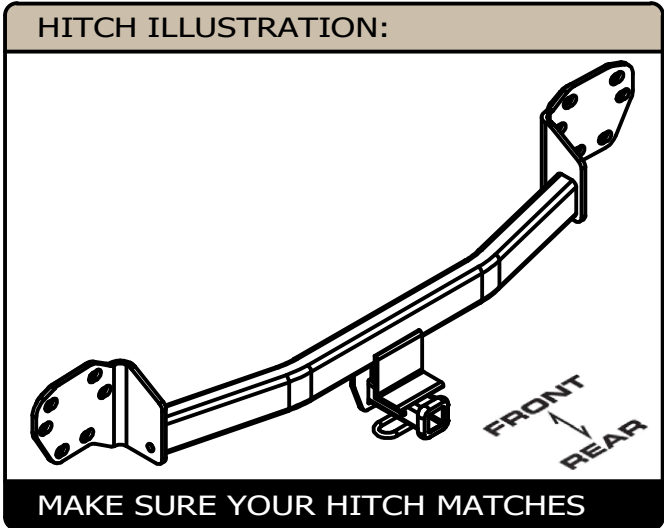

SCAN FOR MORE INFO

PERIODICALLY CHECK THIS RECEIVER HITCH TO ENSURE ALL FASTENERS ARE TIGHT AND ALL STRUCTURAL COMPONENTS ARE SOUND
CURT Manufacturing LLC. warrants this product to be free of defects in material and/or workmanship at the time of retail purchase by the original purchaser. If the product is found to be defective, CURT Manufacturing LLC. may repair or replace the product at their option, when the product is returned, prepaid, with proof of purchase. Alteration to, misuse of, or improper installation of this product voids the warranty. CURT Manufacturing LLC.'s liability is limited to repair or replacement of products found to be defective, and specifically excludes liability for incidental or consequential loss or damage.
For more information log onto www.curtmfg.com
This product complies with safety specifications and requirements for connecting devices and towing systems of the state of New York, V.E.S.C.Regulation V-5 and SAE J684.

INSTALLATION WALKTHROUGH:

Parts List			
ITEM	QTY	PART NUMBER	DESCRIPTION
1	12	10-10393	HHCS,M8x1.25,35,CL10.9,YZ
2	12	30-00148	WASHER,S-CON,3/8,YZ

TRIM DIAGRAM

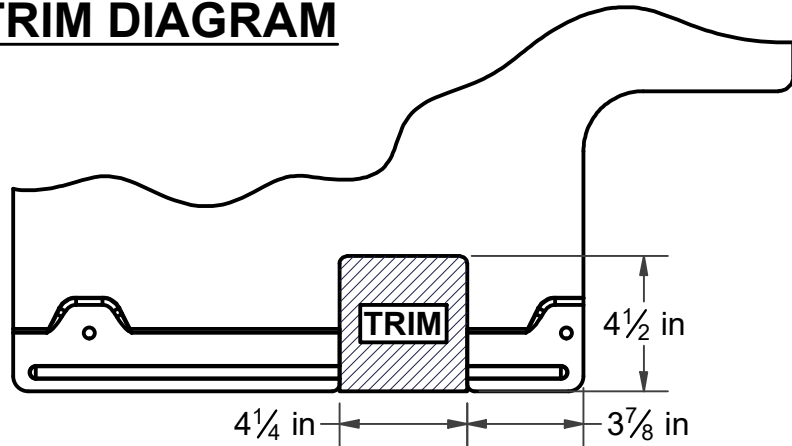

NOTE: TRIM DIMENSIONS ARE APPROXIMATE. CHECK FIT PRIOR TO COMPLETING TRIM.

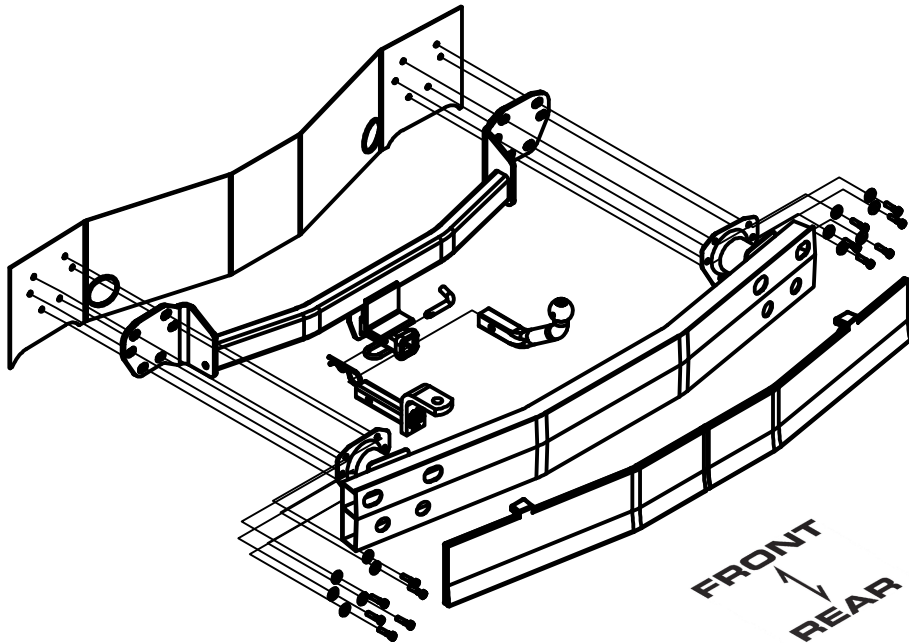

1. Remove underbody panel by removing (7) fasteners. Remove (1) push fastener which holds bumper cover to vehicle next to the tow loop.

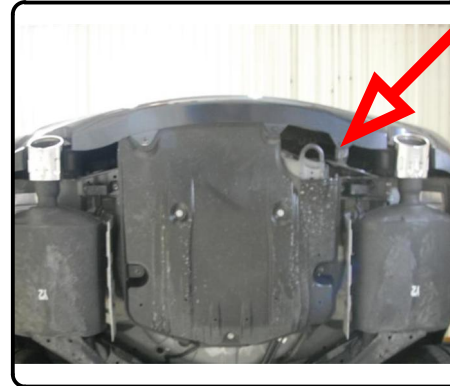

2. Begin bumper cover removal process by removing (2) fasteners behind rear tire.



INSTALLATION WALKTHROUGH:

3. Remove (2) push fasteners from wheel well liner and (2) fasteners from bottom of bumper cover.



4. Pull back wheel well liner to remove (1) hex head fastener.

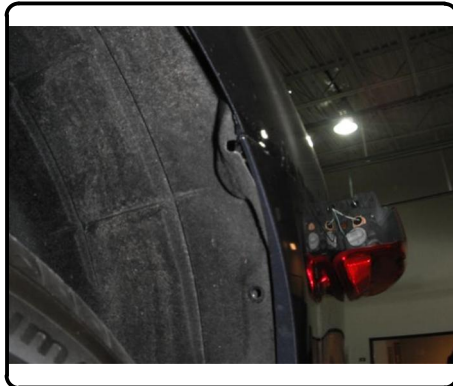

5. Pull back piece of fascia which is glued to bumper cover directly behind rear tire and remove (1) hex fastener.

Repeat STEPS 2-5 on other side of vehicle.

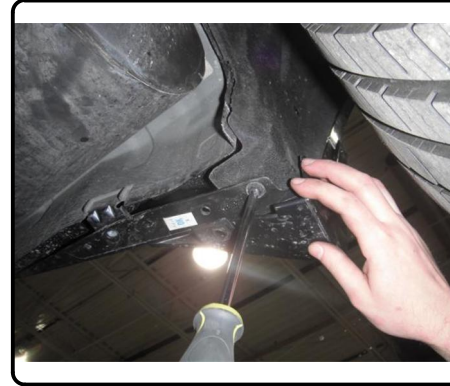

6. Remove trunk floor board which conceals spare tire inside of trunk.



INSTALLATION WALKTHROUGH:

7. Remove rearmost plastic cover inside of trunk by removing (4) loop fasteners and (2) push fasteners.



8. Pull back inner trunk liner to expose and remove (2) hex nuts. It may ease the process to remove push fasteners from inner liner. Repeat on other side.



9. Pop off plastic covers attached to the inside of tail lights.

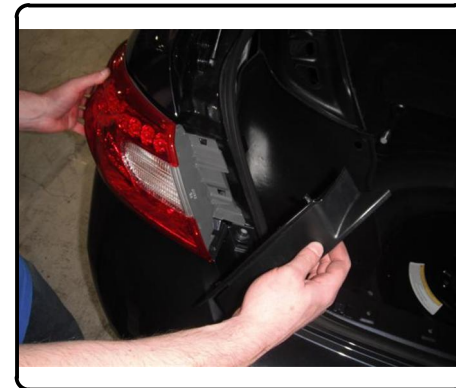

10. Carefully pull off tail lights by pulling straight back.

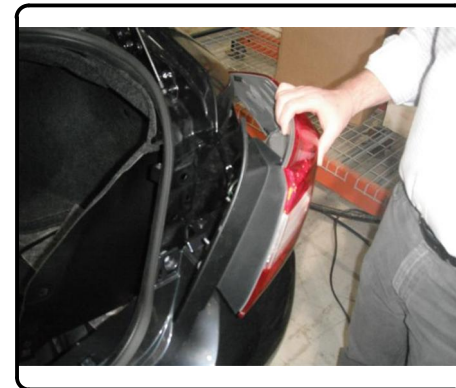

INSTALLATION WALKTHROUGH:

11. Remove (1) hex fastener and (2) push fasteners on each side which were hidden by tail lights.

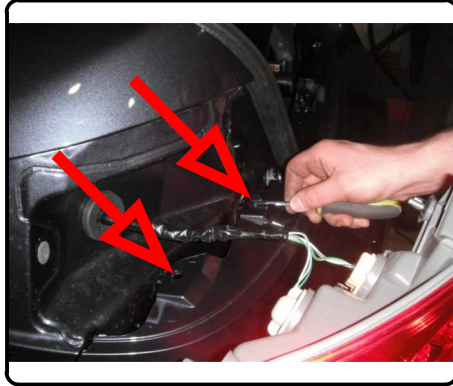

12. Carefully remove bumper cover. Pop sides off first and then pull straight back. **Note:** Remove foam insert and return to vehicle owner.



13. Remove bumper beam by removing (6) M8 fasteners which hold bumper beam supports to trunk pan. Repeat on other each side and return (12) M8 fasteners to vehicle owner.

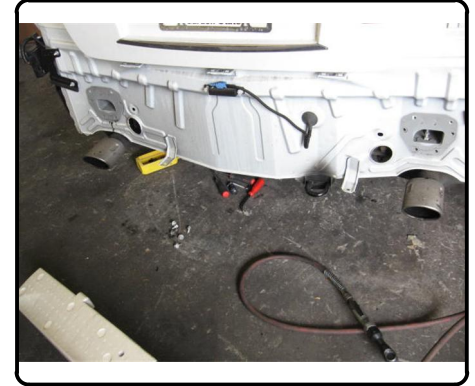

14. Raise hitch and bumper beam into position and secure to vehicle with the included (12) 3/8" conical tooth washers and (12) M8 hex bolts.



INSTALLATION WALKTHROUGH:

15. Torque all M8 hardware to 23 ft-lbs.

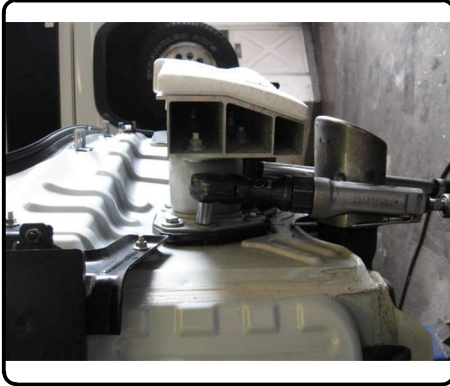

16. Reinstall bumper cover and tail lights by reassembling components removed in STEPS 2-12 in reverse order.



17. Trim underbody panel and reinstall. See TRIM DIAGRAM on PAGE 2.



Install is complete.



11111

INFINITI M37X, M56X, Q70

11/10/2020

PAGE 1 of 2

GROSS LOAD CAPACITY WHEN USED AS A WEIGHT CARRYING HITCH: 2,000 LBS. TRAILER WEIGHT & 200 LBS. TONGUE WEIGHT.

WARNING: ALL NON-TRAILER (WHEEL-LESS) LOADS APPLIED TO THIS PRODUCT MUST BE SUPPORTED BY 18050 STABILIZING STRAPS.



WARNING: ** FAILURE TO PROPERLY SUPPORT NON-TRAILER LOADS WILL VOID PRODUCT WARRANTY **

WARNING: * DO NOT EXCEED VEHICLE MANUFACTURER'S RECOMMENDED TOWING CAPACITY *****



FOR MORE INFORMATION LOG ONTO WWW.CURTMFG.COM
HAVING INSTALLATION QUESTIONS? CALL TECHNICAL SUPPORT AT 877-287-8634

Parts List			
ITEM	QTY	PART NUMBER	DESCRIPTION
1	12	10-10393	HHCS,M8x1.25,35,CL10.9,YZ
2	12	30-00148	WASHER,S-CON,3/8,YZ
8	1	SMALL UPC LABEL	2.00" x 1.00" UPC LABEL

TOOLS REQUIRED
FLAT & PHILLIPS SCREW DRIVER
10mm & 12mm SOCKETS
RATCHET
TORQUE WRENCH
ROTARY TOOL
MARKER

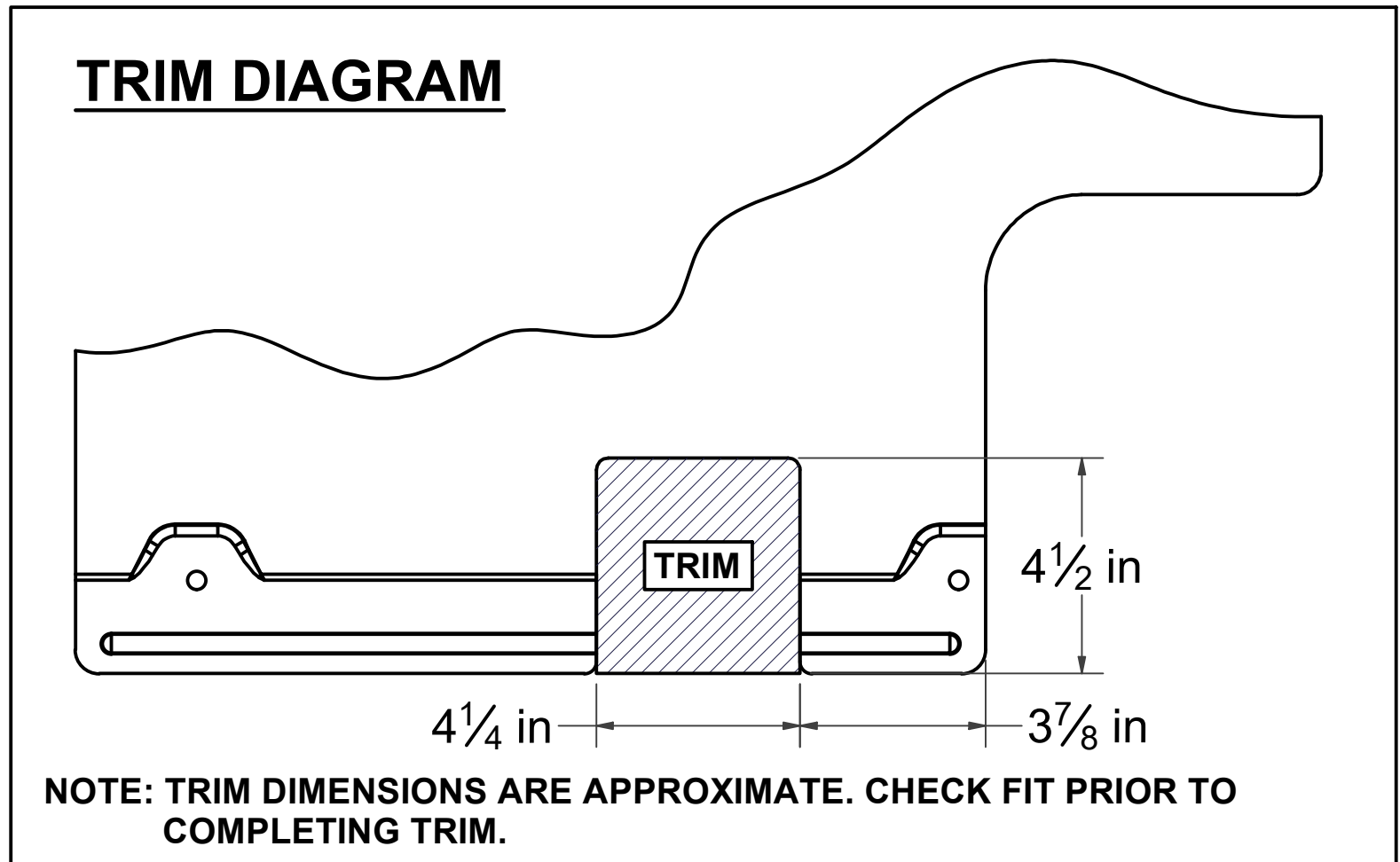
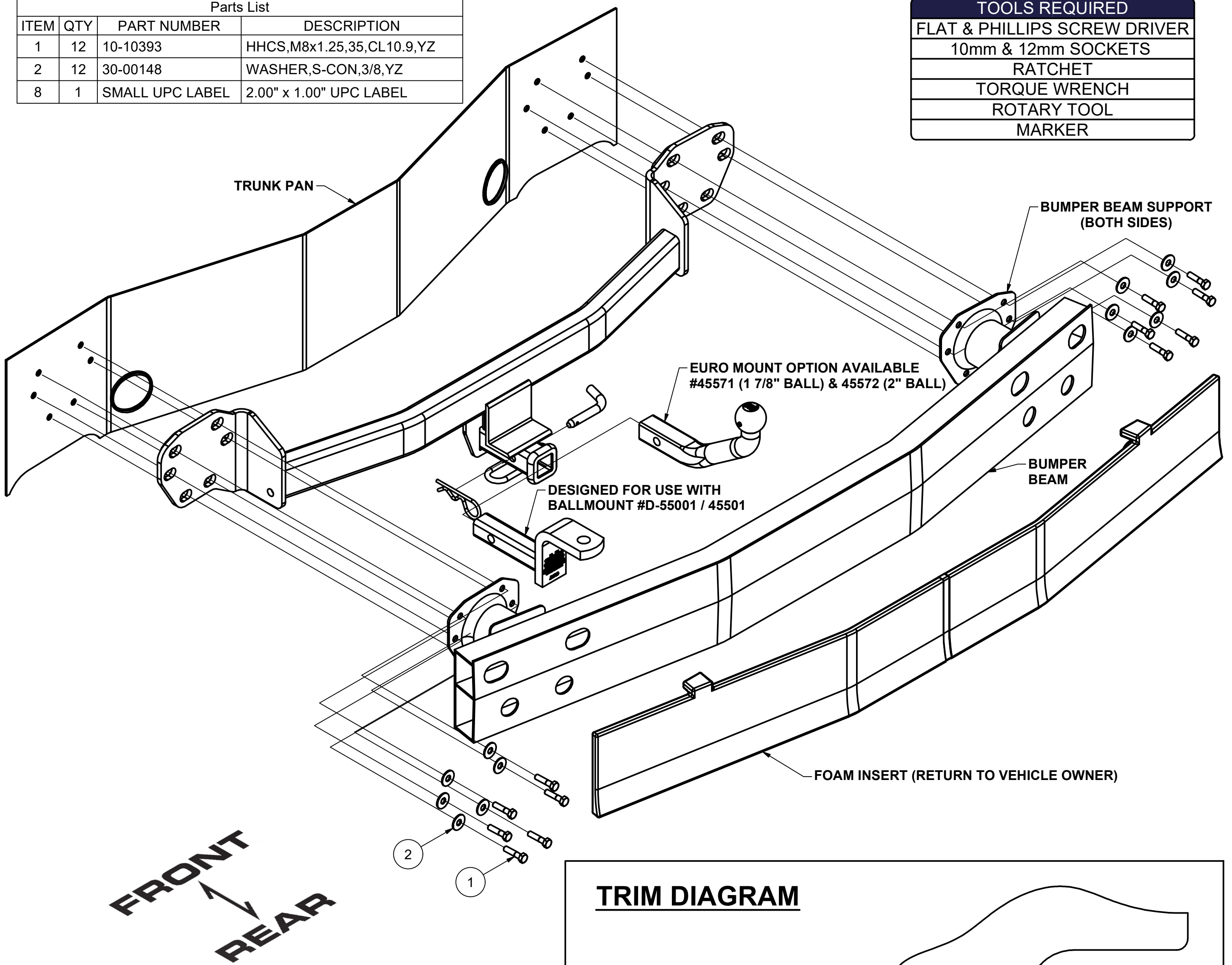

HITCH WEIGHT: 35 LBS.
INSTALL TIME
PROFESSIONAL: 90 MINUTES
NOVICE (DIY): 180 MINUTES
INSTALL NOTES:
-REMOVE BUMPER
-TRIM UNDERBODY PANEL
-NO DRILLING REQUIRED

PERIODICALLY CHECK THIS RECEIVER HITCH TO ENSURE THAT ALL FASTENERS ARE TIGHT AND THAT ALL STRUCTURAL COMPONENTS ARE SOUND.



Scan for more information

CURT Manufacturing LLC., warrants this product to be free of defects in material and/or workmanship at the time of retail purchase by the original purchaser. If the product is found to be defective, CURT Manufacturing LLC., may repair or replace the product, at their option, when the product is returned, prepaid, with proof of purchase. Alteration to, misuse of, or improper installation of this product voids the warranty. CURT Manufacturing LLC.'s liability is limited to repair or replacement of products found to be defective, and specifically excludes liability for incidental or consequential loss or damage.

This product complies with safety specifications and requirements for connecting devices and towing systems of the state of New York, V.E.S.C.Regulation V-5 and SAE J684.

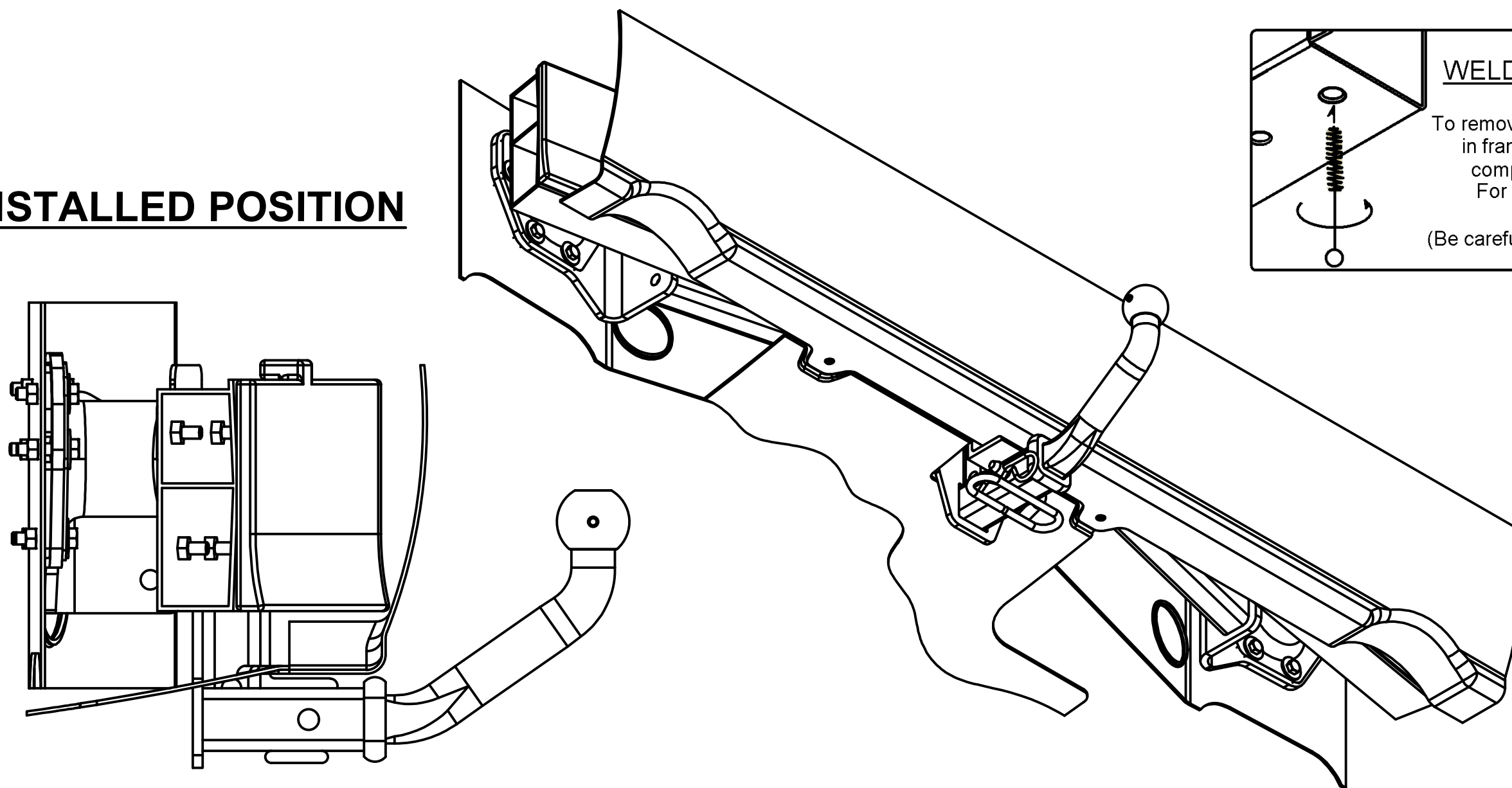
INSTALLED POSITION**WELDNUT CLEANING**

To remove debris from weldnuts in frame, spray lubricant or compressed air into hole. For heavy debris, use a small wire brush. (Be careful not to damage threads).

INSTALLATION STEPS

1. Remove underbody panel by removing (7) fasteners. Remove (1) push fastener which holds bumper cover to vehicle next to the tow loop.
2. Begin bumper cover removal process by removing (2) fasteners behind rear tire.
3. Remove (2) push fasteners from wheel well liner and (2) fasteners from bottom of bumper cover.
4. Pull back wheel well liner to remove (1) hex head fastener.
5. Pull back piece of fascia which is glued to bumper cover directly behind rear tire and remove (1) hex fastener.
6. Repeat STEPS 2-5 on other side of vehicle.
7. Remove trunk floor board which conceals spare tire inside of trunk.
8. Remove rearmost plastic cover inside of trunk by removing (4) loop fasteners and (2) push fasteners.
9. Pull back inner trunk liner to expose and remove (2) hex nuts. It may ease the process to remove push fasteners from inner liner. Repeat on other side.
10. Pop off plastic covers attached to the inside of tail lights.
11. Carefully pull off tail lights by pulling straight back.
12. Remove (1) hex fastener and (2) push fasteners on each side which were hidden by tail lights.
13. Carefully remove bumper cover. Pop sides off first and then pull straight back. **Note:** Remove foam insert and return to vehicle owner.
14. Remove bumper beam by removing (6) M8 fasteners which hold bumper beam supports to trunk pan. Repeat on other each side and return (12) M8 fasteners to vehicle owner.
15. Raise hitch and bumper beam into position and secure to vehicle with the included (12) 3/8" conical tooth washers and (12) M8 hex bolts.
16. Torque all M8 hardware to 23 ft-lbs.
17. Reinstall bumper cover and tail lights by reassembling components removed in STEPS 2-13 in reverse order.
18. Trim underbody panel and reinstall. See TRIM DIAGRAM on PAGE 1.

PERIODICALLY CHECK THIS RECEIVER HITCH TO ENSURE THAT ALL FASTENERS ARE TIGHT AND THAT ALL STRUCTURAL COMPONENTS ARE SOUND.

CURT Manufacturing LLC., warrants this product to be free of defects in material and/or workmanship at the time of retail purchase by the original purchaser. If the product is found to be defective, CURT Manufacturing LLC., may repair or replace the product, at their option, when the product is returned, prepaid, with proof of purchase. Alteration to, misuse of, or improper installation of this product voids the warranty. CURT Manufacturing LLC.'s liability is limited to repair or replacement of products found to be defective, and specifically excludes liability for incidental or consequential loss or damage.

This product complies with safety specifications and requirements for connecting devices and towing systems of the state of New York, V.E.S.C.Regulation V-5 and SAE J684.