

INSTALLATION MANUAL

16024

Level of Difficulty

Easy

Weight Capacity

Gross trailer weight (GTW)	30,000 lbs.
Vertical load	7,500 lbs.

Parts List

Item	Qty	Description
1	2	Leg
2	4	Bolt, locking
3	2	Left handle
4	2	Right handle
5	4	Flat washer
6	4	Castle nut
7	4	Puck
8	2	Safety pin, 3/8" x 1-3/4"
9	4	Cotter pin

Tools Required

Ratchet	Socket, 21mm
Torque wrench	--

Torque Specifications

M14 bolt	100 ft-lbs.
----------	-------------

Use above torque setting unless otherwise noted

Product Registration

CURT Group stands behind our products with industry-leading warranties. Provide feedback and help us to improve our products by registering your purchase at: warranty.curtgroup.com/surveys

⚠ WARNING

Never exceed the vehicle manufacturer's recommended towing capacity. This may result in separation, damage to 5th wheel hitch, vehicle, trailer and / or cause serious injury or death.

Do not expose hands, body parts or clothing anywhere between the truck and trailer. Extreme care should be observed to avoid serious injury to self, property and observers.

Never position yourself or others under the trailer's kingpin area (danger zone) during coupling and uncoupling. Improperly coupled trailers can separate and drop without notice.

Product Photo



NOTICE

Before you begin installation, read all instructions thoroughly.

Proper tools will improve the quality of installation and reduce the time required.

To help prevent damage to the product or vehicle, refer to the specified torque specifications when securing hardware during the installation process.

Maintenance

To protect the product, wax after installing. Regular waxing is recommended to add a protective layer over the finish. Do not use any type of polish or wax that may contain abrasives that could damage the finish.

Mild automotive detergent may be used to clean the product. Do not use dish detergent, abrasive cleaners, abrasive pads, wire brushes or other similar products that may damage the finish.

ASSEMBLY

Parts List

Item	Qty	Description
1	2	Leg
2	4	Bolt, locking
3	2	Left handle
4	2	Right handle
5	4	Flat washer
6	4	Castle nut
7	4	Puck
8	2	Safety pin, 3/8" x 1-3/4"
9	4	Cotter pin

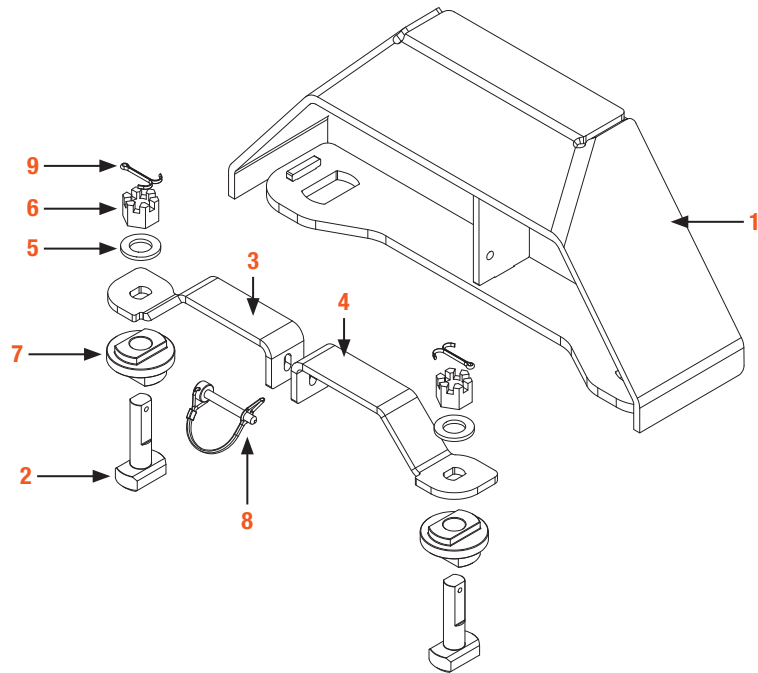

INSTALLATION

Step 1

Remove the safety pin (#8) securing the lock handles (#3, #4) in the closed position and open the handles 90°.

Remove all four cotter pins (#9) securing the castle nuts (#6). Loosen the castle nuts until a minimum of 1/8" clearance between the lock bolt (#2) and the bottom surface of the puck (#7) is achieved.

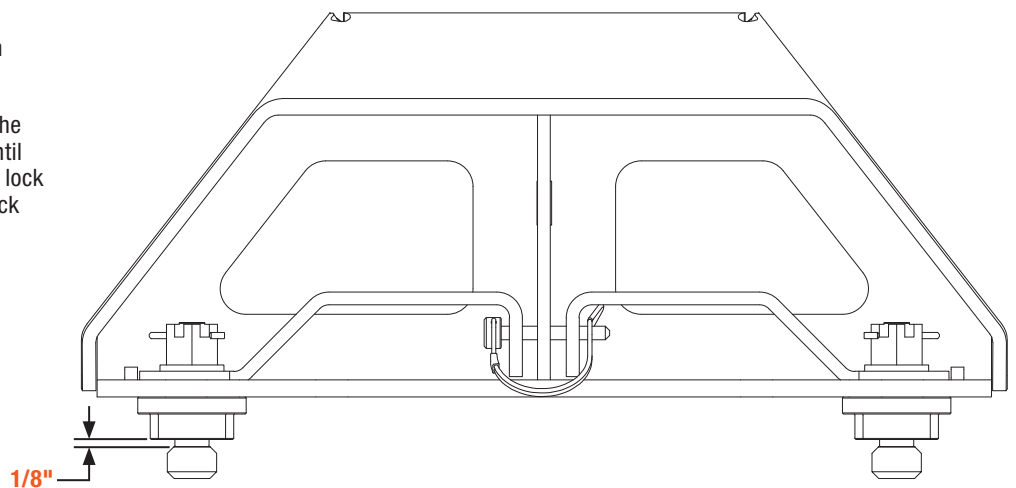

Step 2

Assemble the legs (#1) loosely to the 5th wheel head using the M14 hardware provided with the hitch. Lower the assembly onto the factory mount position in the truck bed.

With the hitch in position, tighten the legs to the head by torquing the bolts to 100 ft-lbs.

Step 3

Adjust the castle nuts tension until the locking bolt (#2) is snug when handles (#3, #4) are rotated to the lock position.

Do not over tighten the castle nuts. The handles should close with moderate hand pressure only. Forcing the handles to the closed position will strip the handles and result in hitch failure.

With the castle nuts adjusted to the proper height for each lock handle, re-install the cotter pins removed in step 1.

Close all four locking handles and secure them using the provided safety pins (#8).