

# INSTALLATION INSTRUCTIONS

**WARNING: NEVER EXCEED YOUR VEHICLE MANUFACTURER'S RECOMMENDED TOWING CAPACITY**

## CHANNEL-MOUNT FORGED PINTLE & BALL

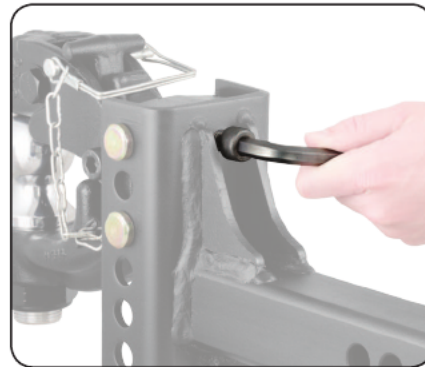

Figure 1

### USE

Install the adjustable channel-mount shank into the trailer hitch of the vehicle and secure with a hitch pin & clip. Always secure the hitch pin with a clip unless a locking device is being used.

Raise or lower the pintle to the desired height and insert the channel-mount system pins through the holes that line up with the holes in the channel-mount. Secure the pins with clips. **NOTE:** There are pins & clips specifically engineered for the channel-mount system. If replacement pins are needed, they must be replaced with original factory channel-mount pins.

After the pintle is set to the correct height and secured, tighten the anti-rattle set screw tightly into the channel-mount to eliminate noise. See figure 1. **NOTE:** Use of a set screw is not needed for safety; only to eliminate possible rattle between the channel-mount shank and the pintle.

If towing with the trailer ball, open the pintle latch by removing the safety pin and pulling up on the lock while lifting the latch. Replace the safety pin to retain the open latch position. Position the coupler over the trailer ball and lock it into place following the instructions of the coupler manufacturer.

Prior to towing check to make sure the pins are secured into place with clips. Never hook up trailer safety chains to the channel-mount system.

### PARTS LIST

Part#	Ball Size	Gross Trailer Weight / Tongue Weight
45919	2"	10,000 / 1,000 lbs.
45920	2 5/16"	13,000 / 1,300 lbs.
45922	2 5/16"	20,000 / 2,000 lbs.

### WARNINGS

Do not exceed vehicle's towing capacity or trailer hitch capacity, whichever is less. See your vehicle owner's manual to determine vehicle tow rating.

This pintle hitch can only be used with the channel-mount system. Use of any channel-mount other than that of the channel-mount system manufacturer could be a serious safety hazard and will void the warranty.

Ensure that the safety chains operate freely around the channel-mount system and do not become entangled in the channel-mount system.

Before towing, ensure the pintle ball is torqued to 260 ft. lbs.

**DISCLAIMER:** The ratings of the channel-mount system are intended to represent the capability of the product and in no way reflect the ratings or capacity of the towing system it is being used with. The consumer or operator are strongly advised to learn the ratings of the various components of the towing system and never exceed the limits of the lowest rated component being used.