

# INSTALLATION MANUAL

# 58000

## Level of Difficulty

Easy

## Parts List

Qty	Description	#
8	Nylock nut, M5 - 0.8	1
2	Carriage bolt, M5 - 0.8 x 20mm	2
2	Carriage bolt, M5 - 0.8 x 90mm	3
4	Pan head slotted screw, M5 - 0.8 x 20mm	4
1	Mounting bracket	5
2	Spacer	6

## Tools Required

Wrench set      Socket set

## Product Photo

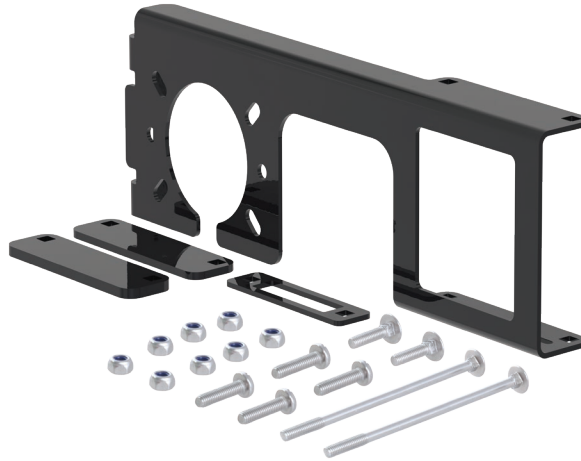

## Notes and Maintenance

Before you begin installation, read all instructions thoroughly.

Proper tools will improve the quality of installation and reduce the time required.

Mild automotive detergent may be used to clean the product. Do not use dish detergent, abrasive cleaners, abrasive pads, wire brushes or other similar products that may damage the finish.

## Product Registration

CURT Group stands behind our products with industry leading warranties. You can help us continue to improve our product line and help us understand your needs by registering your purchase by visiting:

[warranty.curtgroup.com/surveys](http://warranty.curtgroup.com/surveys)

At CURT Group, customer is king. We value your feedback and we use that information to make improvements on our products. Please, take a minute and let us know how we are doing.

# ASSEMBLY

## Parts List

Qty	Description	#
8	Nylock nut, M5 - 0.8	1
2	Carriage bolt, M5 - 0.8 x 20mm	2
2	Carriage bolt, M5 - 0.8 x 90mm	3
4	Pan head slotted screw, M5 - 0.8 x 20mm	4
1	Mounting bracket	5
2	Spacer	--

## Step 1

**Note:** Prior to installing the electrical bracket, check for adequate clearance for the bracket, plug(s) and wiring. Forming the lower bracket flange prior to installation can help create a tighter fit during installation. Do this by pushing the lower flange against the ground until it creates a snug fit around the receiver tube. See Detail A.

Attach the 6- or 7-way plug and your 4- or 5-way flat using the provided hardware, as shown. Tighten the hardware evenly until snug. Overtightening the hardware can cause the front of the bracket to bow or the hardware to break.

## Step 2

Slide the electrical bracket over the receiver tube collar.

**Note:** Use the supplied spacers (#6) as needed if there is a larger gap between the collar and the electrical bracket.

## Step 3

Secure the electrical bracket to the receiver tube collar using the provided hardware, as shown.

