

GROSS LOAD CAPACITY WHEN USED AS A WEIGHT CARRYING HITCH: 30,000 LBS. TRAILER WEIGHT & 7,500 LBS. TONGUE WEIGHT.

*****DO NOT EXCEED VEHICLE MANUFACTURER'S RECOMMENDED TOWING CAPACITY.*****

HAVING INSTALLATION QUESTIONS? CALL TECHNICAL SUPPORT AT 1-877-287-8634

WARNING!! BRAKE, FUEL, AND ELECTRICAL LINES MAY NEED TO BE LOOSENED OR REPOSITIONED TO PROVIDE CLEARANCE FOR NEW HARDWARE. SOME MODELS REQUIRE MODIFICATION OR REMOVAL OF HEAT SHIELDS. ON SHORT BED MODELS, CHECK FOR ADEQUATE TURNING CLEARANCE BETWEEN THE FRONT OF ALL TRAILERS AND THE TRUCK CAB.

Parts List			
ITEM	QTY	PART NUMBER	DESCRIPTION
A	1	60614-WA	GOOSENECK CENTER SECTION
B	2	60614-NPW	NUT PLATE WELDMENT
C	1	66155	RUBBER COVER
D	1	60601	60601 GOOSENECK BALL
E	1	60614-CL	CENTER LOCATOR / TRIM SHIELD

NOTE: REQUIRES DRILLING THROUGH THE FACTORY CROSSMEMBER (4) PLACES FOR SAFETY CHAIN LOOPS

Hardware List			
ITEM	QTY	PART NUMBER	DESCRIPTION
1	4	10-10553	FB,PATCH,5/8-11 UNC,1-1/2,GRD8,YZ
2	4	20-00135	NUT,CTR LOCK,5/8-18 UNF,GRDA,ZP
3	2	60614-UB	5/8" SQUARE U-BOLT
4	4	CM-C113-UBS	U-BOLT SPRING
5	8	30-00087	WASHER, FLAT,M16

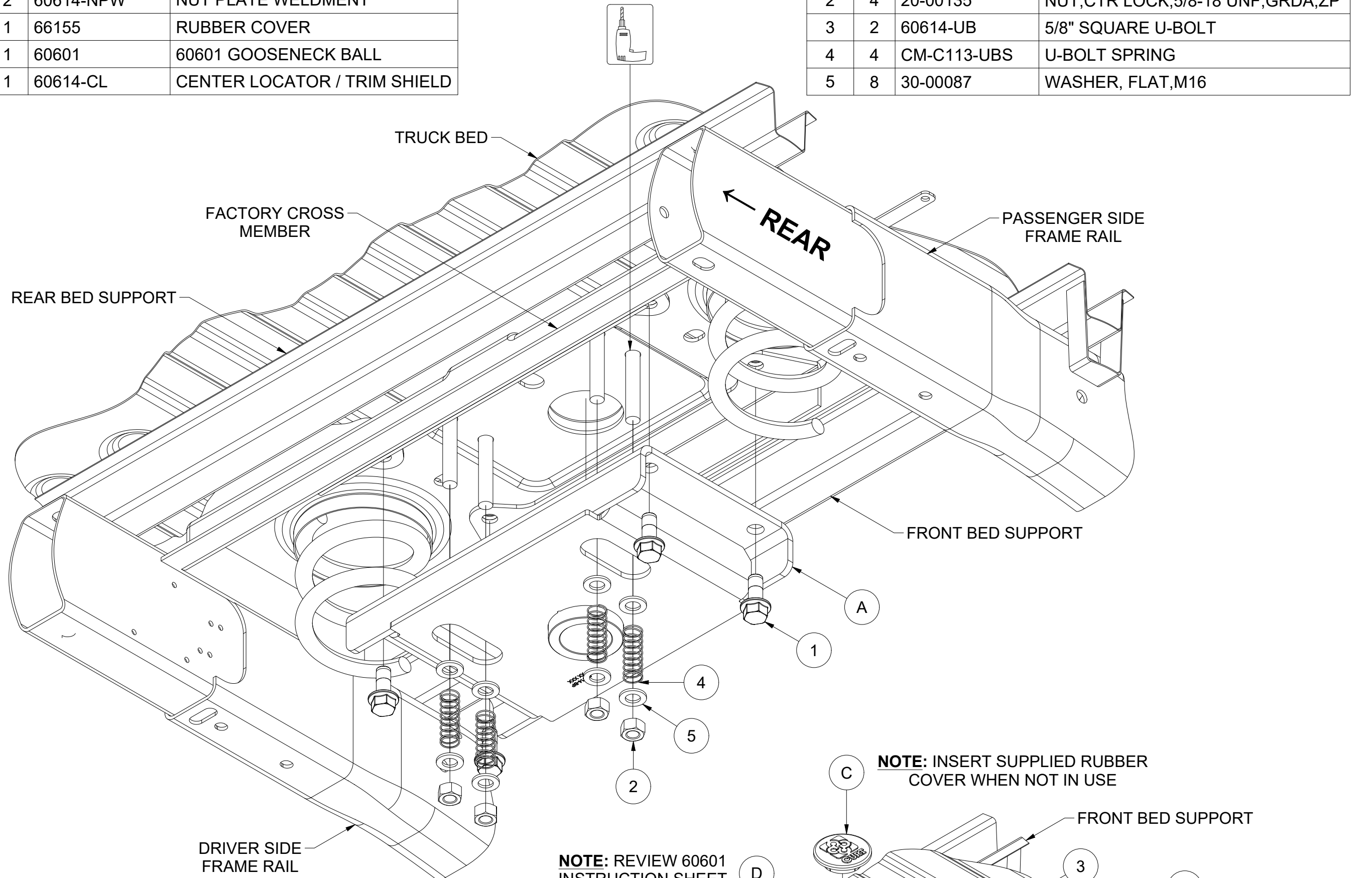

NOTE: INSERT SUPPLIED RUBBER COVER WHEN NOT IN USE

NOTE: REVIEW 60601 INSTRUCTION SHEET PRIOR TO USE

INSTALL CENTER LOCATOR INTO CYLINDER PRIOR TO RAISING GOOSENECK CENTER SECTION INTO POSITION

TRUCK BED (TRIMMED FOR CLARITY)

DRIVER SIDE FRAME RAIL

FACTORY CROSS MEMBER

FRONT BED SUPPORT

REAR BED SUPPORT

PASSENGER SIDE FRAME RAIL

INSTALLED HITCH

TOOLS REQUIRED
TORQUE WRENCH
RATCHET
15/16" SOCKET EXTENSION
DRILL
3-1/4" HOLE SAW
3/16" & 11/16" DRILL BIT
PRY BAR
CUTTING FLUID
RUST INHIBITOR
EAR PROTECTION
SAFETY GLASSES

HITCH WEIGHT: 52 LBS.

INSTALL TIME

PROFESSIONAL: 45 MINUTES

NOVICE (DIY): 90 MINUTES

INSTALL NOTES:

- LOWER SPARE TIRE
- LOWER EXHAUST
- NO MEASURING DRILL LOCATIONS
- NO DRILLING INTO FRAME

PERIODICALLY CHECK THIS RECEIVER HITCH TO ENSURE THAT ALL FASTENERS ARE TIGHT AND THAT ALL STRUCTURAL COMPONENTS ARE SOUND.



Scan for more information

CURT Manufacturing LLC., warrants this product to be free of defects in material and/or workmanship at the time of retail purchase by the original purchaser. If the product is found to be defective, CURT Manufacturing LLC., may repair or replace the product, at their option, when the product is returned, prepaid, with proof of purchase. Alteration to, misuse of, or improper installation of this product voids the warranty. CURT Manufacturing LLC.'s liability is limited to repair or replacement of products found to be defective, and specifically excludes liability for incidental or consequential loss or damage.

GROSS LOAD CAPACITY WHEN USED AS A WEIGHT CARRYING HITCH: 30,000 LBS. TRAILER WEIGHT & 7,500 LBS. TONGUE WEIGHT.

*****DO NOT EXCEED VEHICLE MANUFACTURER'S RECOMMENDED TOWING CAPACITY.*****

HAVING INSTALLATION QUESTIONS? CALL TECHNICAL SUPPORT AT 1-877-287-8634

WARNING!! BRAKE, FUEL, AND ELECTRICAL LINES MAY NEED TO BE LOOSENED OR REPOSITIONED TO PROVIDE CLEARANCE FOR NEW HARDWARE. SOME MODELS REQUIRE MODIFICATION OR REMOVAL OF HEAT SHIELDS. ON SHORT BED MODELS, CHECK FOR ADEQUATE TURNING CLEARANCE BETWEEN THE FRONT OF ALL TRAILERS AND THE TRUCK CAB.

INSTALLATION STEPS:

1. Temporarily remove spare tire. Lower exhaust by removing the (3) rear most rubber exhaust hangers, see **rubber isolator removal diagram**. **Note:** For ease of installation temporarily remove (4) fasteners and lower the heat shield between the exhaust and the spare tire.
2. Prior to installing nut plates, run a bolt in and out of each weldnut to ensure a clean thread. From inside the rear wheel wells slide the 60614-NPW (B) between the factory cross member and the bed of the truck. Make sure the weldnuts in the nut plates are aligned with the holes in the factory cross members. **Note:** You will have to slide the 60614-NPW (B) under a wire harness next to the driver side frame rail. Flexing/bending the nut plate handles downward will allow them to slide under the wheel well liners.
3. From under the truck, lift the gooseneck center section (A) into position with the center locator installed and secure with 5/8-11 x 1-1/2" hex flange bolts. **Note:** The rear axle breather hose may need to be relocated prior to hitch installation. Torque all 5/8" fasteners to 150 ft-lbs.
4. From under the truck, drill a pilot hole through the center locator using a 3/16" drill bit. Move to inside the truck bed and finish drilling the 3-1/4" hole. **Note:** Use cutting fluid to ease this process. Deburr hole, remove any center locator remnants and spray exposed metal with rust inhibitor.
5. From under the truck using the safety chain holes in the gooseneck center section (A) as a drill guide, drill (4) 11/16" holes up through the factory cross member and truck bed. **Note:** Drilling a small pilot hole prior to the 11/16" hole will ease this process. Drill must be perpendicular to the cross member and bed.
6. Install U-bolts from inside the truck bed, ensure that they sit flat when in the lower position and slide easily without binding. Enlarge holes as needed for proper operation. Deburr holes and spray exposed metal with rust inhibitor.
7. From under the truck place a washer (5), a spring (4), a washer (5), and a nut (2) on each of the four U-bolt legs. Tighten the nuts until flush with the bottom of the U-bolt.
8. Reinstall exhaust hangers, heat shield (if removed), and spare tire.

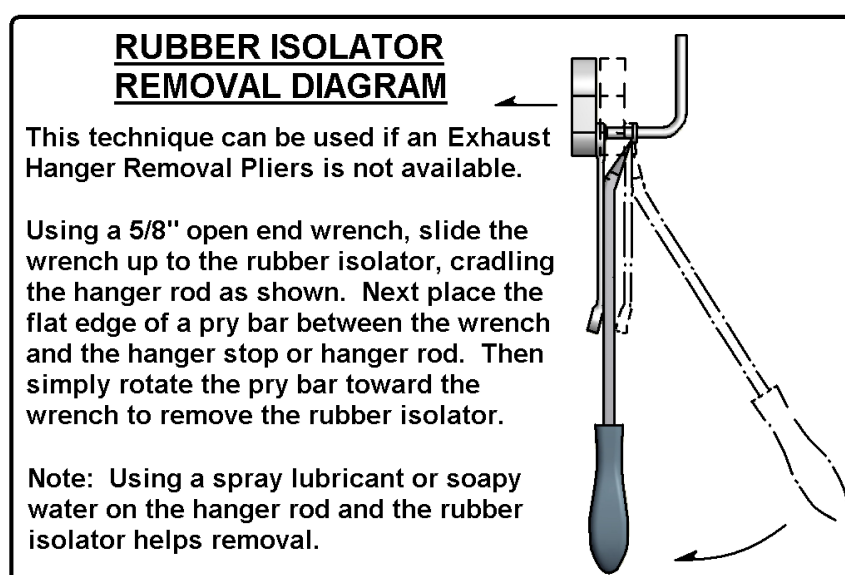

PERIODICALLY CHECK THIS RECEIVER HITCH TO ENSURE THAT ALL FASTENERS ARE TIGHT AND THAT ALL STRUCTURAL COMPONENTS ARE SOUND.

CURT Manufacturing LLC., warrants this product to be free of defects in material and/or workmanship at the time of retail purchase by the original purchaser. If the product is found to be defective CURT Manufacturing LLC., may repair or replace the product, at their option, when the product is returned, prepaid, with proof of purchase. Alteration to, misuse of, or improper installation of this product voids the warranty. CURT Manufacturing LLC.'s liability is limited to repair or replacement of products found to be defective, and specifically excludes liability for incidental or consequential loss or damage.

CAB TO TRAILER CLEARANCE

*****DO NOT EXCEED VEHICLE MANUFACTURER'S RECOMMENDED TOWING CAPACITY.*****

HAVING INSTALLATION QUESTIONS? CALL TECHNICAL SUPPORT AT 1-877-287-8634

****REMOVAL OF REAR WINDOW ACCESSORIES MAY BE REQUIRED****

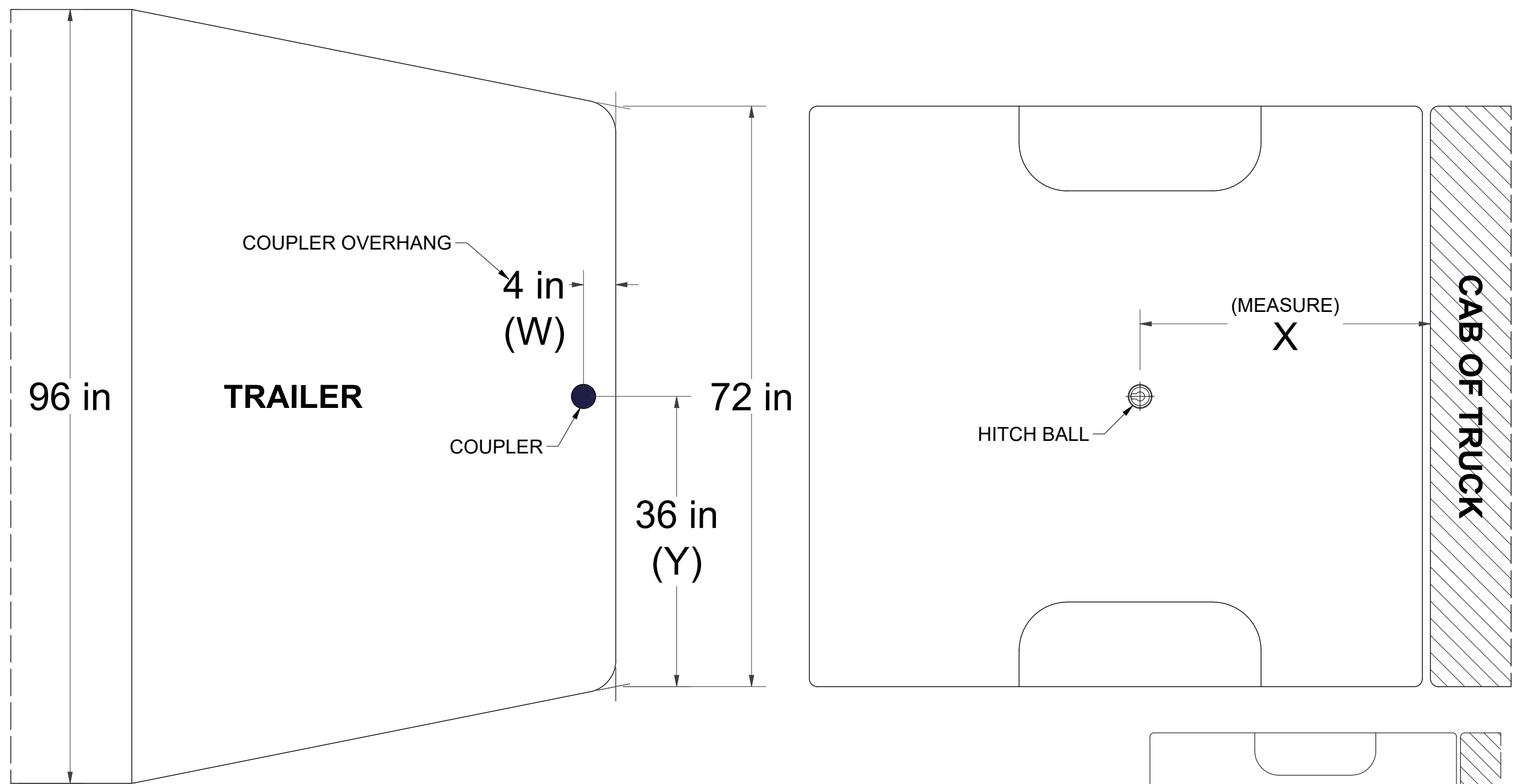

****GENERALLY, TAPERED NOSE TRAILERS ADHERE TO THE FOLLOWING DESIGNS:****
 8 FT. WIDE TRAILERS TAPER TO 6 FT. AT THE COUPLER
 7 FT. WIDE TRAILERS TAPER TO 5 FT. AT THE COUPLER

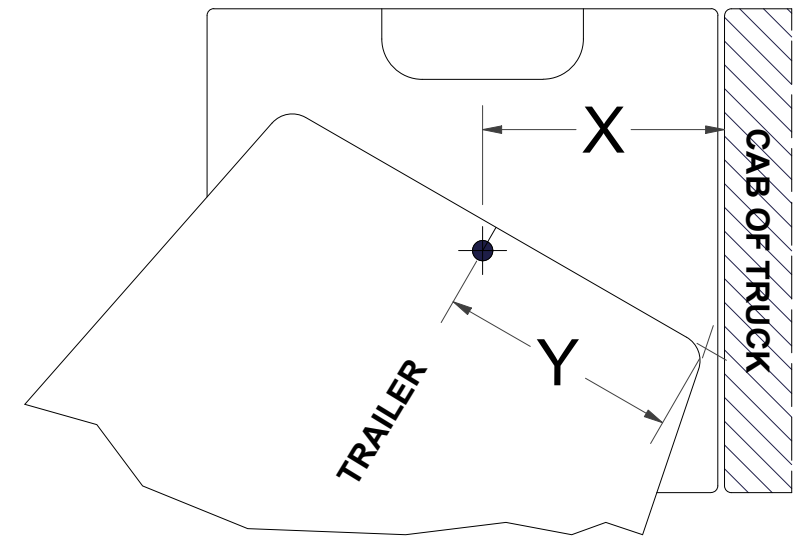

CLEARANCE CALCULATION

$$\begin{matrix} \text{(CAB TO BALL CENTER)} & - & 1/2 \text{ (TRAILER WIDTH)} & = & \text{(MINIMUM CLEARANCE)} \\ \text{(X)} & & \text{(Y)} & & \text{(Z)} \end{matrix}$$

IF THERE IS AN OVERHANG FROM THE COUPLER THEN THE EQUATION IS:

$$\begin{matrix} \text{[(X) - (W)]} & - & \text{(Y)} & = & \text{(Z)} \end{matrix}$$

*****IF (Z) IS POSITIVE, TRAILER WILL NOT INTERFERE WITH CAB OF TRUCK.*****
IF (Z) IS NEGATIVE, TRAILER WILL INTERFERE WITH CAB OF TRUCK!!!

EXAMPLE:

STANDARD TRAILER

$$\begin{matrix} X - Y = Z \\ 35 - 36 = -1 \\ \text{(TRAILER WILL INTERFERE WITH CAB)} \end{matrix}$$

TRAILER WITH OVERHANG

$$\begin{matrix} \text{[(X) - (W)]} - Y = Z \\ \text{[35 - 4]} - 36 = -5 \\ \text{(TRAILER WILL INTERFERE WITH CAB)} \end{matrix}$$

YOUR CALCULATION:

(CAB TO BALL CENTER) _____

(COUPLER OVERHANG) _____

1/2 (TRAILER WIDTH) _____

(MINIMUM CLEARANCE) _____

PERIODICALLY CHECK THIS RECEIVER HITCH TO ENSURE THAT ALL FASTENERS ARE TIGHT AND THAT ALL STRUCTURAL COMPONENTS ARE SOUND.

CURT Manufacturing LLC., warrants this product to be free of defects in material and/or workmanship at the time of retail purchase by the original purchaser. If the product is found to be defective CURT Manufacturing LLC., may repair or replace the product, at their option, when the product is returned, prepaid, with proof of purchase. Alteration to, misuse of, or improper installation of this product voids the warranty. CURT Manufacturing LLC.'s liability is limited to repair or replacement of products found to be defective, and specifically excludes liability for incidental or consequential loss or damage.

IMPORTANT TOWING INFORMATION

PAGE 4 OF 4

*****DO NOT EXCEED VEHICLE MANUFACTURER'S RECOMMENDED TOWING CAPACITY.*****

HAVING INSTALLATION QUESTIONS? CALL TECHNICAL SUPPORT AT 1-877-287-8634

BEFORE TOWING THE FIRST TIME:

- Verify adequate turning clearance between the truck cab / box corners and trailer(s).
- Check truck box clearance. There should be a minimum clearance of 6" between the bottom of the trailer(s) overhang and the top of the box sides.
- Verify all hardware is torqued to the proper specification.
- Verify the trailer safety chain length. Too much slack in the chain may prevent maintaining control in the event of separation. Leave only enough slack to allow full turning without interference.
- Verify the trailer attachments to the safety chain loops are secure (cannot be shaken free during towing).

MAINTENANCE:

- Keep gooseneck ball, receiver, and trailer coupler lubricated regularly. Use silicone spray or equivalent to prevent wear / rust.
- Keep gooseneck ball, receiver, and trailer coupler free of dirt and other foreign debris.
Note: Failure to maintain your towing system could result in poor performance and/or catastrophic failure.

BEFORE TOWING EVERY TIME:

- Ensure all fasteners are tight and that all structural components are sound.
Note: Do not tow trailer with worn or damaged parts.
- Attach trailer securely to safety chain loops.
- Ensure the trailer weight does not exceed any part of your towing system. Be sure load is heavier towards front of the trailer while not exceeding the hitch tongue weight. Be sure trailer load is secured to prevent shifting and centered from left to right. **Note:** Never load the trailer heavier behind the trailer axle(s).
- Check tires to ensure they are inflated to the proper specification. Follow vehicle and trailer recommendations.
- Verify trailer lights, electric brakes, and breakaway switches are working properly.

WARNING!!

- Vehicle performance (braking, handling, acceleration, turning radius) can be drastically affected by the trailer. Allow additional time / space for stopping, changing lanes, passing and turning.
- Do not tow more than one trailer at a time. This may cause loss of control.
- Severe bumps can damage your towing system. Avoid or drive slowly over rough terrain.

PERIODICALLY CHECK THIS RECEIVER HITCH TO ENSURE THAT ALL FASTENERS ARE TIGHT AND THAT ALL STRUCTURAL COMPONENTS ARE SOUND.

CURT Manufacturing LLC., warrants this product to be free of defects in material and/or workmanship at the time of retail purchase by the original purchaser. If the product is found to be defective CURT Manufacturing LLC., may repair or replace the product, at their option, when the product is returned, prepaid, with proof of purchase. Alteration to, misuse of, or improper installation of this product voids the warranty. CURT Manufacturing LLC.'s liability is limited to repair or replacement of products found to be defective, and specifically excludes liability for incidental or consequential loss or damage.