

# INSTALLATION MANUAL

# 70129

## Level of Difficulty

Moderate

Installation difficulty levels are based on time and effort involved and may vary depending on the installer level of expertise, condition of the vehicle and proper tools and equipment.

## Installed Attachment Tabs

Height	17-1/4"
Width	24"

## Parts List

Item	Qty	Description
1	1	Tow bar base plate, universal
2	2	Tow bar mounting tab
3	2	Safety cable, 7,500 lbs.
4	2	Spacer plates
5	2	Carriage bolt, 1/2"-13 x 1-3/4", grade 8
6	4	Carriage bolt, 3/8"-16, 1-1/2", grade 8
7	2	Carriage bolt, 1/2"-13 x 2", grade 8
8	4	Serrated-flange nut, 3/8"-16, grade 8
9	4	Serrated-flange nut, 1/2"-13, grade 8
10	2	Socket plug
11	2	Quick link, 1/2"
12	4	Fishwire, 1/2"
13	4	Fishwire, 3/8"
14	2	Round-hole spacer, 1/2" x 1-1/4" x 2-1/2"
15	2	Square-hole spacer, 3/8" x 1-1/4" x 2-1/2"
16	2	Square-hole spacer, 1/4" x 1-1/4" x 2-1/2"
17	4	Square-hole spacer, 1/4" x 1" x 2"

## Tools Required

Torque wrench	Drill
Socket, 7/16"	Drill bit, 1/2"
Socket, 16mm	Die grinder with carbide bit
Socket, 18mm	Large vise grip
Wrench, 7/16"	Tape
Wrench, 16mm	--

## ⚠ WARNING

Never exceed the vehicle manufacturer's recommended gross vehicle weight rating (GVWR).

## Product Photo



Not pictured: Safety cables, quick links and socket plugs

## ⚠ CAUTION

Take care when cutting any plastic or metal as injury may occur if done improperly.

## NOTICE

Visit [www.curtmfg.com](http://www.curtmfg.com) for a full-color copy of this instruction manual, as well as helpful videos, guides and much more!

Before you begin installation, read all instructions thoroughly.

Proper tools will improve the quality of installation and reduce the time required.

This installation requires:

- Removal of underbody panel
- Temporary removal of underbody shield
- Trimming and drilling
- Fishwiring to install hardware

To help prevent damage to the product or vehicle, refer to the specified torque specifications when securing hardware during the installation process.

If equipped, we recommend removing the base plate attachment tabs when not in use.

## SAFETY INSTRUCTIONS

Safety glasses should be worn at all times while installing this product.

## Product Registration and Warranty

CURT stands behind our products with industry-leading warranties. To get copies of the product warranties, register your purchase or provide feedback, visit: [warranty.curtgroup.com/surveys](http://warranty.curtgroup.com/surveys)

# ASSEMBLY

## Parts List

Item	Qty	Description
1	1	Tow bar base plate, universal
2	2	Tow bar mounting tab
3	2	Safety cable, 7,500 lbs.
4	2	Spacer plates
5	2	Carriage bolt, 1/2"-13 x 1-3/4", grade 8
6	4	Carriage bolt, 3/8"-16, 1-1/2", grade 8
7	2	Carriage bolt, 1/2"-13 x 2", grade 8

## Parts List

Item	Qty	Description
8	4	Serrated-flange nut, 3/8"-16, grade 8
9	4	Serrated-flange nut, 1/2"-13, grade 8
10	2	Socket plug
11	2	Quick link, 1/2"
12	4	Fishwire, 1/2"
13	4	Fishwire, 3/8"

## Parts List

Item	Qty	Description
14	2	Round-hole spacer, 1/2" x 1-1/4" x 2-1/2"
15	2	Square-hole spacer, 3/8" x 1-1/4" x 2-1/2"
16	2	Square-hole spacer, 1/4" x 1-1/4" x 2-1/2"
17	4	Square-hole spacer, 1/4" x 1" x 2"

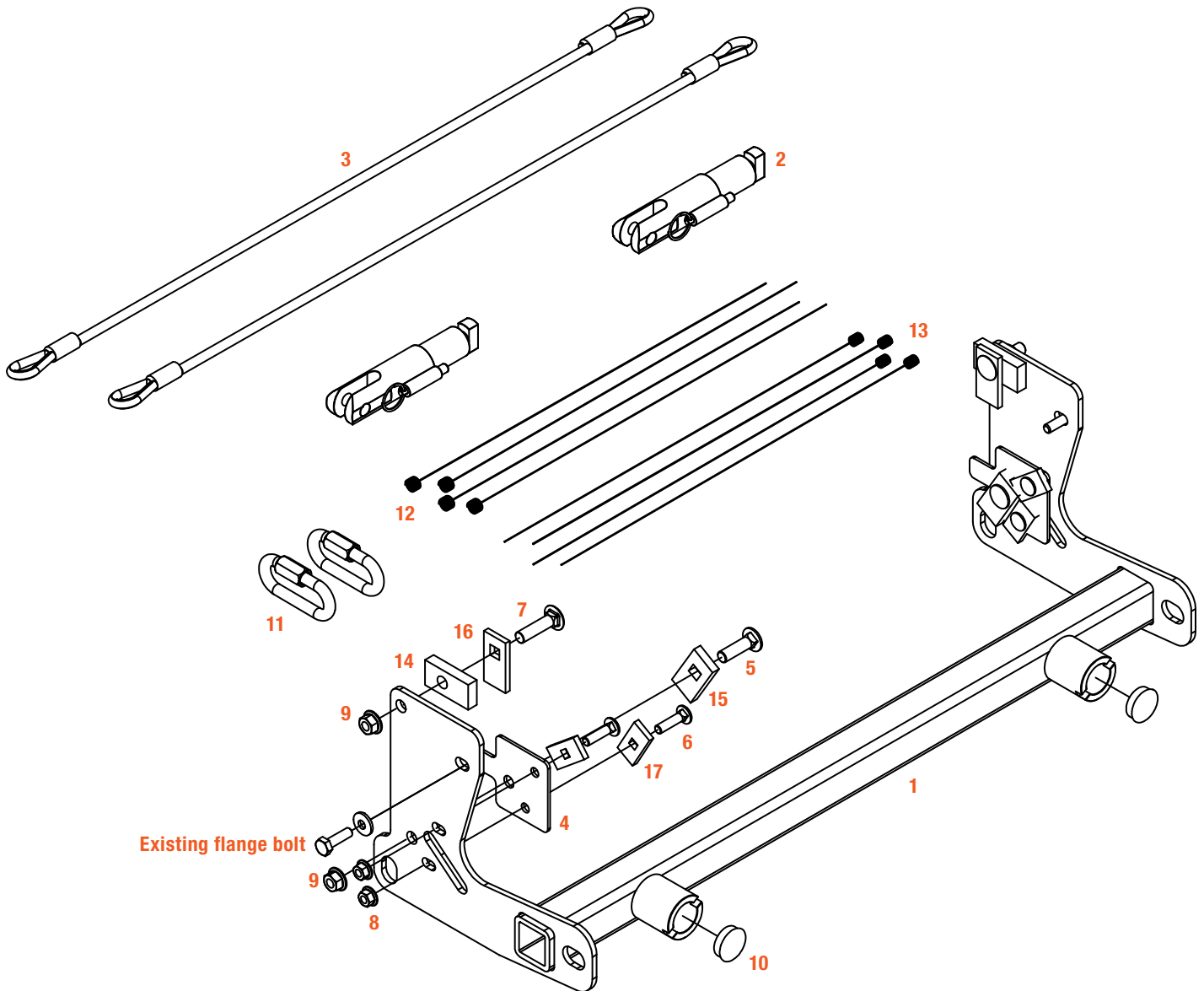

# BUMPER REMOVAL

## Step 1

Remove the two push pins on top of the plastic trim behind the bumper



## Step 2

**Rubicon with Plastic Bumper:** Use a 13mm socket to remove four bolts from the underbody panel and set aside.

**Rubicon with Steel Bumper:** Use a 13mm socket to remove seven bolts from the underbody panel, five toward the front and two at the back. Temporarily remove the underbody panel and set aside.

**Sport & Sport S:** Remove eight push pins from the underbody panel and use a 8mm socket to remove two bolts. Temporarily remove the underbody panel and set aside.

**Overland:** To remove the underbody panel, remove nine push pins along the front and two bolts at the rear with a 8mm socket. Temporarily remove the underbody panel and set aside

## Step 3

**Sport, Sport S, & Overland Models:** Use a 16mm socket to remove the two bolts from the debris guard. Lift the guard to unhook and set aside.

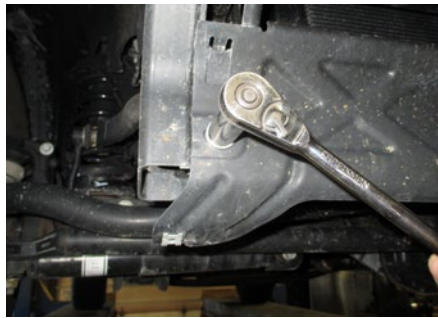

#### Step 4

Unplug the gray electrical connector on the passenger side as shown.



#### Step 5

Use an 18mm socket to remove four nuts on each side, attaching the bumper to the vehicle. Temporarily remove the underbody panel and set aside.

**All Models:** Remove the outer frame brackets with a 16mm socket.

**Rubicon with Plastic Bumper Models:** Remove the small underbody panel bracket by removing two bolts with a 16mm socket. Temporarily remove the underbody panel bracket from each side and set aside.

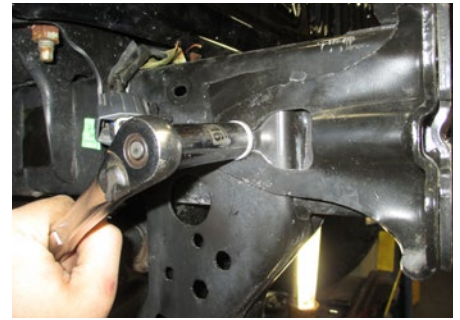
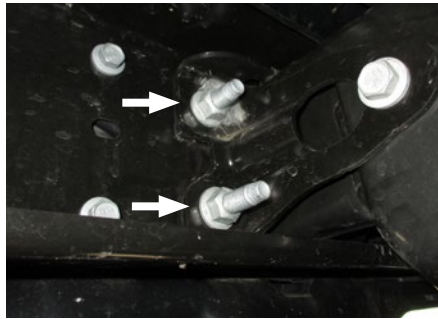



# TOW BAR BASE PLATE INSTALLATION

## Step 6

Enlarge the lower center slot in the frame as needed on both vehicle sides for the hardware to pass through.

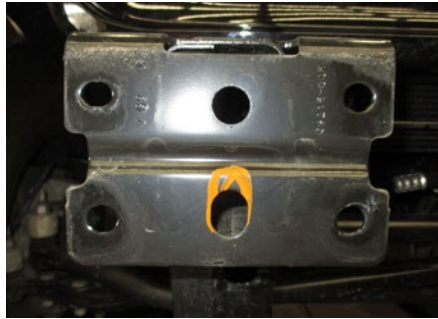

## Step 7

Use a strip of tape to hold the outer frame brackets (removed in step 5) in place. Use the factory 10mm bolts to loosely secure the base plate weldment to the frame.

Line up the holes in the frame with the base plate, making sure the base plate is level. Snug the two 10mm bolts.

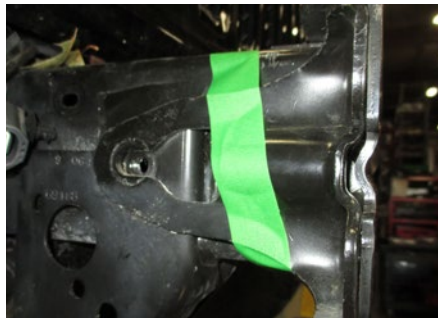

## Step 8

### Rubicon with Plastic Bumper Models:

Reinstall the small underbody panel bracket between the frame and the base plate (#1) and reinstall the two existing 10mm flange bolts removed in step 5.

Fishwire (#12) one 1/2" x 1-3/4" carriage bolt (#5) and square-hole spacer (#15) into the lower rearward hole. The hole may require enlarging for the 1/2" bolt. Loosely install the 1/2" serrated-flange nut (#9) and repeat on the other side of the vehicle.



**All Other Models:** Slide the spacer plate (#4) between the frame and the base plate (#1) as shown. To allow for more room, pry the plate out to slide the spacer plate into position.

Fishwire (#13) two 3/8" carriage bolts (#6) and square-hole spacers (#17) into position and secure with serrated-flange nuts (#8). Fishwire (#12) one 1/2" x 1-3/4" carriage bolt (#5) and square-hole spacer (#15) into the lower rearward hole. The hole may require enlarging for the 1/2" bolt. Loosely install a 1/2" serrated-flange nut (#9) and repeat on the other side of the vehicle.



## Step 9

Use the base plate (#1) as a guide to drill two 1/2" holes for the upper rearward fasteners.

Fishwire (#12) the remaining 1/2" x 2" carriage bolts (#7) and square-hole spacers (#16) into position and secure with 1/2" serrated-flange nuts (#9) on both sides of the vehicle.

Be sure to position the round-hole spacers (#14) between the frame and base plate while fishwiring the hardware into position.



## Step 10

Torque all 3/8" fasteners to 37 ft-lbs.  
and all 1/2" fasteners to 110 ft-lbs.

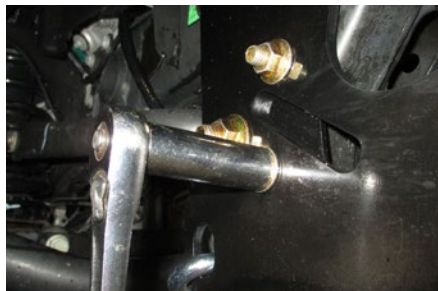

### Step 11

Install the permanent safety cables (#3) and quick links (#11), looping them around the vehicle frame and linking them to the tow bar base plate (#1). There must be one cable on each side of the vehicle.

Make sure the cables do not pinch or interfere with any hoses, wiring or other components.

See 'Installing the Permanent Base Plate Safety Cables' for additional information.

#### **Sport, Sport S, & Overland Models:**

Reinstall the debris guard removed in step 3.

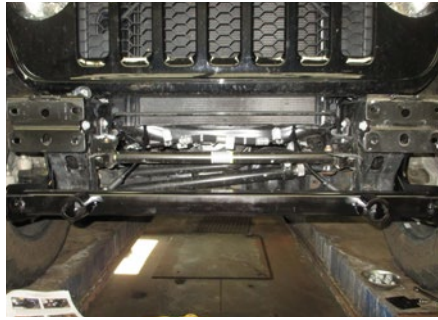

### Step 12

Trim underbody panel as noted below.

**Rubicon with Plastic Bumper:** Measure from the middle of the small underbody panel bracket hole to the inside of the base plate mounting plate and mark. Then measure and mark for the outer side of the base plate mounting plate. To get the length of the slot needed, measure from the middle of the small underbody panel bracket hole to the rearward edge of the base plate mounting plate. Hold the underbody panel in position and adjust the trimmed slot as needed.

Reinstall the underbody panel when finished trimming.

**All Other Models:** Hold underbody panel close to the mounting location, mark, and trim slots.

### Step 13

Reinstall the bumper and plug in the electrical for the fog lights.

When ready to tow, install the tow bar mounting tabs (#2). When not towing, insert the socket plugs (#10) into the end of the tow bar base plate (#1).

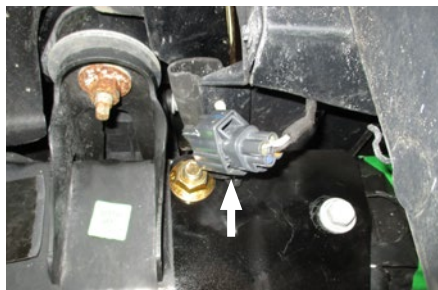



## Final Installed Image



# SAFETY CABLE INSTALLATION

## Installing the Permanent Base Plate Safety Cables

When dinghy towing a vehicle with a tow bar, base plate safety cables should be used at all times. In the event of a disconnect, the safety cables are designed to help prevent complete vehicle separation. When installing the safety cables, use the illustrations below as a guide.

### Installation guidelines

1. The cables must be connected to the base plate and the vehicle frame.
2. Two cables must be installed.
3. Each cable must meet or exceed the gross weight of the towed vehicle.
4. Make sure cables do not pinch or interfere with hoses, wiring or other components.

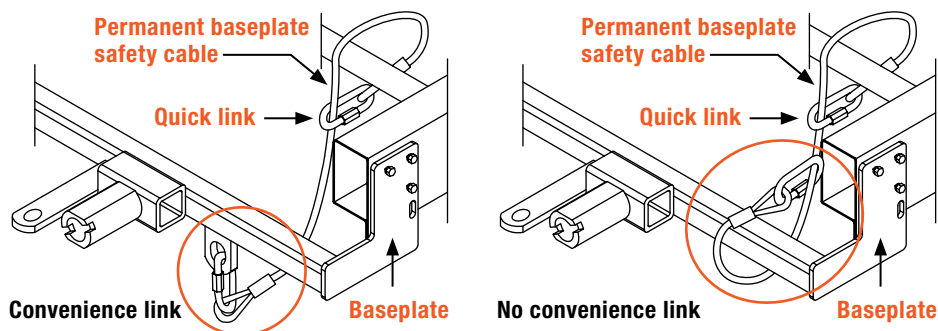

**Note:** Base plate safety cables are not a replacement for safety chains connecting the tow vehicle to the towed vehicle.

# ADDITIONAL INFORMATION

## Towing Tips

### Check your equipment

Periodically check the condition of all towing equipment. Ensure all fasteners are tight and that all structural components are sound. Do not tow with worn or damaged parts.

### Towing vehicle and trailer manufacturer's recommendations

Review the owner's manual for your towing vehicle and trailer for specific recommendations, capacities and requirements.