



Safety glasses should be worn at all times while installing this product.

YEARS: 2013

MAKE: BUICK/CHEVROLET

MODEL: ENCORE/TRAX

STYLE: CROSSOVER

WARNING: NEVER EXCEED YOUR VEHICLE MANUFACTURER'S RECOMMENDED TOWING CAPACITY

WEIGHT CARRYING:
 TRAILER WEIGHT: 2,000 LBS.
 TONGUE WEIGHT: 200 LBS.

WARNING:
 WE RECOMMEND THE USE OF 18050 STABILIZING STRAPS FOR ALL NON-TRAILER (WHEEL-LESS) LOADS. PLEASE SEE THE CURT CATALOG OR VISIT US ONLINE AT WWW.CURTMFG.COM FOR FURTHER INFORMATION.

PRO INSTALL TIME: 30 MIN.
NOVICE INSTALL TIME: 60 MIN.

IF YOU ARE HESITANT TO UNDERTAKE THIS TASK ON YOUR OWN, CONTACT AN AUTHORIZED CURT INSTALLER FOR ADDITIONAL ASSISTANCE.

INSTALLATION TIPS:

- BEFORE YOU BEGIN INSTALLATION, READ ALL INSTRUCTIONS THOROUGHLY.
- TO EASE INSTALLATION, 2 PEOPLE MAY BE REQUIRED.
- USING PROPER TOOLS WILL GREATLY IMPROVE THE QUALITY OF THE INSTALL AND REDUCE THE TIME REQUIRED.
- NEED HELP OR HAVE SOME QUESTIONS? CALL TECHNICAL SUPPORT AT 800.798.0813



INSTALLATION REQUIRES:

SAFETY GLASSES	SPRAY LUBRICANT	DIE GRINDER
CUT-OFF WHEEL	RATCHET	6" SOCKET EXTENSION
SOCKET 11/16"	TORQUE WRENCH	

LEVEL OF DIFFICULTY: MODERATE

EASY	MODERATE	CHALLENGING
	LOWER EXHAUST FOR EASE OF INSTALLATION	
	HOLE ENLARGEMENT REQUIRED	
	TRIMMING REQUIRED	
	FISHWIRING REQUIRED	

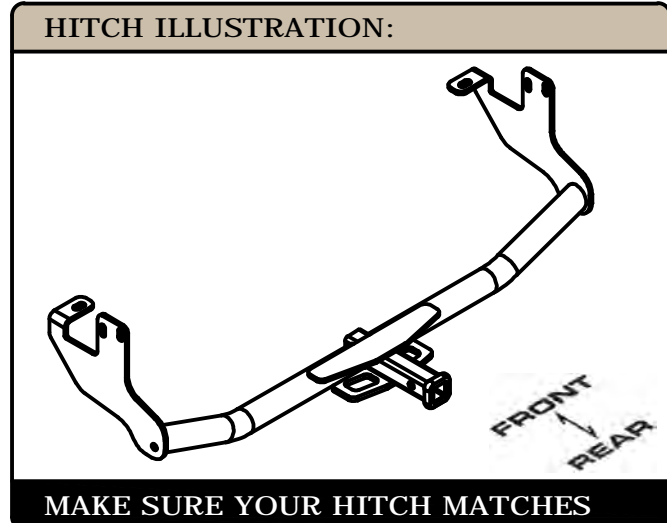

PERIODICALLY CHECK THIS RECEIVER HITCH TO ENSURE ALL FASTENERS ARE TIGHT AND ALL STRUCTURAL COMPONENTS ARE SOUND

CURT Manufacturing LLC. warrants this product to be free of defects in material and/or workmanship at the time of retail purchase by the original purchaser. If the product is found to be defective, Curt Manufacturing LLC. may repair or replace the product at their option, when the product is returned, prepaid, with proof of purchase. Alteration to, misuse of, or improper installation of this product voids the warranty. Curt Manufacturing LLC.'s liability is limited to repair or replacement of products found to be defective, and specifically excludes liability for incidental or consequential loss or damage.

For more information log onto www.curtmfg.com, & for helpful towing tips log onto www.hitchinfo.com

INSTALLATION WALKTHROUGH:

Parts List			
ITEM	QTY	PART NUMBER	DESCRIPTION
1	6	7_16 - 14 x 1 1_4 CARRIAGE (GRADE 8)	CARRIAGE BOLT
2	6	7_16 FISHWIRE	7/16" FISHWIRE
3	6	CM-SP2	.250 x .88 x 2.25" SQUARE HOLE SPACER
4	6	7/16-14	HEX FLANGE NUT
5	4	M12-1.25 x 30mm	HEX BOLT
6	4	1/2	CONICAL TOOTHED WASHER
7	4	M12-1.75 x 30mm	HEX BOLT

HARDWARE USAGE WILL VARY WITH APPLICATION

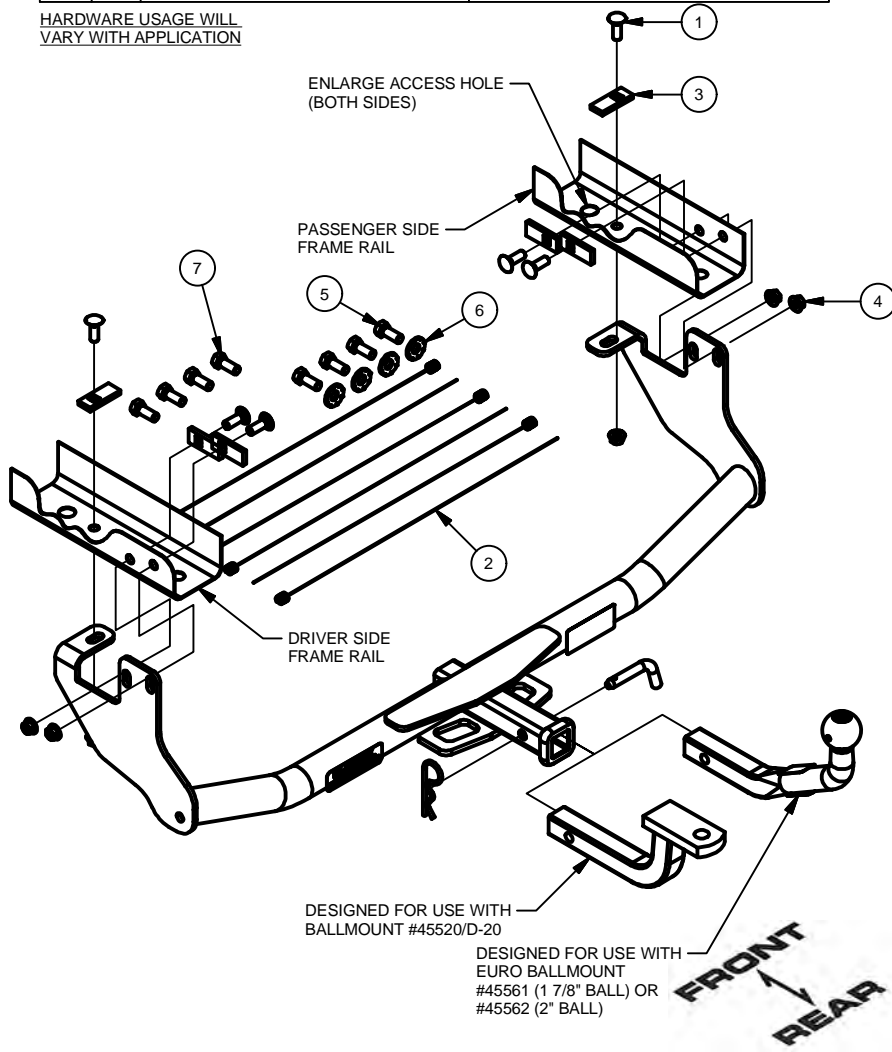

1) Lower rear exhaust hangers from one location on each side of the vehicle. For ease of installation, the exhaust can also be lowered in one location at the front center of the vehicle. This location will need to be lowered slowly and supported from underneath during install.

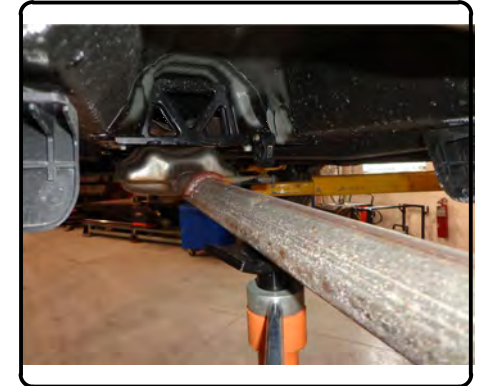

2) The wheel well plastic on each side of the vehicle near the frame rails will need to be trimmed to provide a flush fit for the hitch side plates. Be sure to avoid the vehicle brake lines when cutting the plastic away.



INSTALLATION WALKTHROUGH:

- 3) Enlarge the access holes in the vehicle frame in order to fit the SP2 spacers provided in the hardware kit. Be sure to avoid the vehicle brake lines when cutting the frame material away.

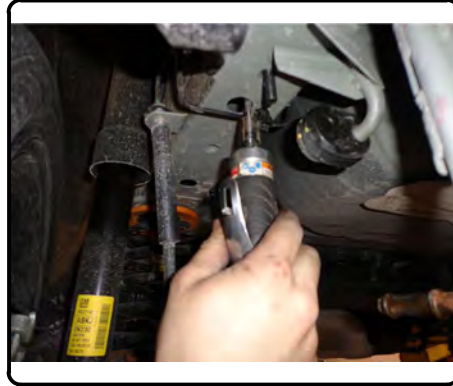

- 4) Fishwire spacers and 7/16" bolts through access holes and into the bottom mounting holes in the vehicle frame. Raise hitch into position and loosely secure in place with the 7/16" nuts provided.



- 5a) If no weldnuts exist in frame, fishwire the hardware for the vertical mounting points through the framerrail and the hitch side plates. Secure all 7/16" hardware.
b) If weldnuts exist in frame, then secure hitch with M12 bolts and 1/2" conical washers in the side mounting plates



- 6) Torque all 7/16" hardware to 70 lb-ft.
Torque all M12 hardware to 86 lb-ft.
Raise exhaust hangers back into position.

Installation is complete

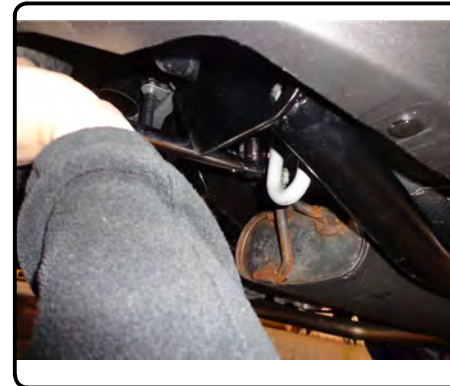

11358

BUICK ENCORE/CHEVROLET TRAX

11/13/2017

GROSS LOAD CAPACITY WHEN USED AS A WEIGHT CARRYING HITCH: 2,000 LBS. TRAILER WEIGHT & 200 LBS. TONGUE WEIGHT.

DO NOT EXCEED VEHICLE MANUFACTURER'S RECOMMENDED TOWING CAPACITY.

WARNING: ALL NON-TRAILER LOADS APPLIED TO THIS PRODUCT MUST BE SUPPORTED BY 18050 STABILIZING STRAPS.

** FAILURE TO PROPERLY SUPPORT NON-TRAILER LOADS WILL VOID PRODUCT WARRANTY**

HAVING INSTALLATION QUESTIONS? CALL TECHNICAL SUPPORT AT 1-800-798-0813

Parts List			
ITEM	QTY	PART NUMBER	DESCRIPTION
1	6	7_16 - 14 x 1 1_4 CARRIAGE (GRADE 8)	CARRIAGE BOLT
2	6	7_16 FISHWIRE	7/16" FISHWIRE
3	6	CM-SP2	.250 x .88 x 2.25" SQUARE HOLE SPACER
4	6	7/16-14	HEX FLANGE NUT
5	4	M12-1.25 x 30mm	HEX BOLT
6	4	1/2 CONICAL TOOTHED WASHER	WASHER, CONICAL, TOOTHED, 1/2"
7	4	M12-1.75 x 30mm	HEX BOLT

RUBBER ISOLATOR REMOVAL DIAGRAM

This technique can be used if an Exhaust Hanger Removal Pliers is not available.

Using a 5/8" open end wrench, slide the wrench up to the rubber isolator, cradling the hanger rod as shown. Next place the flat edge of a pry bar between the wrench and the hanger stop or hanger rod. Then simply rotate the pry bar toward the wrench to remove the rubber isolator.

Note: Using a spray lubricant or soapy water on the hanger rod and the rubber isolator helps removal.

HARDWARE USAGE WILL VARY WITH APPLICATION

PASSENGER SIDE FRAME RAIL

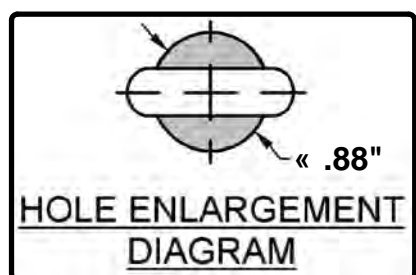

ENLARGE ACCESS HOLE (BOTH SIDES)

DRIVER SIDE FRAME RAIL

DESIGNED FOR USE WITH EURO BALLMOUNT #45561 (1 7/8" BALL) OR #45562 (2" BALL)

TOOLS REQUIRED
SPRAY LUBRICANT
DIE GRINDER
RATCHET
SOCKET EXTENSION
11/16" SOCKET
TORQUE WRENCH

FISHWIRE TECHNIQUE

INSERT COILED END OF FISHWIRE TOOL THROUGH HITCH MOUNTING HOLE IN VEHICLE FRAME RAIL AND OUT THE ACCESS HOLE. PASS COILED END OF FISHWIRE THROUGH SPACER AND THREAD BOLT INTO COIL. KINK WIRE TO KEEP SPACER SEPERATE FROM BOLT AS SHOWN. PULL FISHWIRE, SPACER, AND BOLT THROUGH FRAME AND OUT MOUNTING HOLE. USE FISHWIRE TO GUIDE HITCH DURING MOUNTING AND PREVENT LOSS OF BOLT / SPACER INSIDE FRAME RAIL.

NOTE: SOME VEHICLES MAY FISHWIRE THROUGH END OF FRAME

DESIGNED FOR USE WITH BALLMOUNT #45520/D-20

FRONT
REAR

INSTALLATION STEPS

- 1) Lower rear exhaust hangers from one location on each side of the vehicle. For ease of installation, the exhaust can also be lowered in one location at the front center of the vehicle. This location will need to be lowered slowly and supported from underneath during install.
- 2) The wheel well plastic on each side of the vehicle near the frame rails will need to be trimmed to provide a flush fit for the hitch side plates. Be sure to avoid the vehicle brake lines when cutting the plastic away.
- 3) Enlarge the access holes in the vehicle frame in order to fit the SP2 spacers provided in the hardware kit. Be sure to avoid the vehicle brake lines when cutting the frame material away.
- 4) Fishwire spacers and 7/16" bolts through access holes and into the bottom mounting holes in the vehicle frame. Raise hitch into position and loosely secure in place with the 7/16" nuts provided.
- 5a) If no weldnuts exist in frame, fishwire the hardware for the side mounting points through the framerail and the hitch side plates. Secure all 7/16" hardware.
- b) If weldnuts exist in frame, then secure hitch with M12 bolts and 1/2" conical washers in the side mounting points.
- 6) Torque all 7/16" hardware to 70 lb-ft. Torque all M12 hardware to 86 lb-ft. Raise exhaust hangers back into position.

PERIODICALLY CHECK THIS RECEIVER HITCH TO ENSURE THAT ALL FASTENERS ARE TIGHT AND THAT ALL STRUCTURAL COMPONENTS ARE SOUND.

Curt Manufacturing LLC., warrants this product to be free of defects in material and/or workmanship at the time of retail purchase by the original purchaser. If the product is found to be defective, Curt Manufacturing LLC., may repair or replace the product, at their option, when the product is returned, prepaid, with proof of purchase. Alteration to, misuse of, or improper installation of this product voids the warranty. Curt Manufacturing LLC.'s liability is limited to repair or replacement of products found to be defective, and specifically excludes liability for incidental or consequential loss or damage.