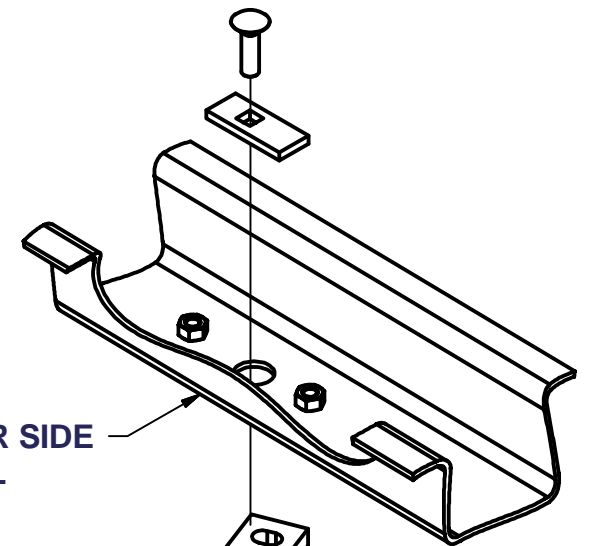
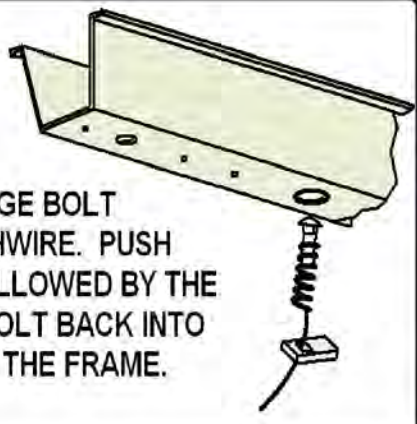

11555**HONDA CR-V****7/17/2012****GROSS LOAD CAPACITY WHEN USED AS A WEIGHT CARRYING HITCH: 2,000 LBS. TRAILER WEIGHT & 200 LBS. TONGUE WEIGHT.****WARNING: ALL NON-TRAILER LOADS APPLIED TO THIS PRODUCT MUST BE SUPPORTED BY 18050 STABILIZING STRAPS.****WARNING: ** FAILURE TO PROPERLY SUPPORT NON-TRAILER LOADS WILL VOID PRODUCT WARRANTY ******WARNING: *** DO NOT EXCEED VEHICLE MANUFACTURER'S RECOMMENDED TOWING CAPACITY *******FOR MORE INFORMATION LOG ONTO WWW.CURTMFG.COM
HAVING INSTALLATION QUESTIONS? CALL TECHNICAL SUPPORT AT 1-800-798-0813**

Parts List			
ITEM	QTY	PART NUMBER	DESCRIPTION
1	1	1/2-13 x 2 1/2 LG.	CARRIAGE BOLT
2	3	CM-SP12	.250 x 1.00 x 2.00" SQUARE HOLE SPACER
3	1	HFN 1213	HEX FLANGE NUT
4	2	7_16 FISHWIRE	7/16" FISHWIRE
5	2	7/16-14 x 1 1/2	CARRIAGE BOLT
6	2	7/16-14	HEX FLANGE NUT
7	2	CM-SP11	.250 x 1.00 x 2.50" SQUARE HOLE SPACER

FRONT
REAR**PASSENGER SIDE
FRAME RAIL****REVERSE PULL FISHWIRE
TECHNIQUE**

ATTACH FISHWIRE TO CARRIAGE BOLT AND SLIDE SPACER ONTO FISHWIRE. PUSH THE BOLT THRU THE HOLE FOLLOWED BY THE SPACER (AS SHOWN). PULL BOLT BACK INTO POSITION, PROTRUDING FROM THE FRAME.

**RUBBER ISOLATOR
REMOVAL DIAGRAM**

This technique can be used if an Exhaust Hanger Removal Pliers is not available.

Using a 5/8" open end wrench, slide the wrench up to the rubber isolator, cradling the hanger rod as shown. Next place the flat edge of a pry bar between the wrench and the hanger stop or hanger rod. Then simply rotate the pry bar toward the wrench to remove the rubber isolator.

Note: Using a spray lubricant or soapy water on the hanger rod and the rubber isolator helps removal.

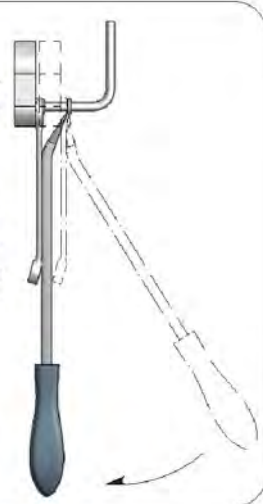
**DRIVER SIDE
FRAME RAIL****ENLARGE EXISTING HOLES****TOW LOOP****3.00 in****4.00 in****DESIGNED FOR USE WITH
BALLMOUNT #55001 / 45501****NOTE: DIMENSIONS ARE
APPROXIMATE, CONFIRM
FIT PRIOR TO TRIMMING****13.50 in** **3.00 in****UNDERBODY PANEL TRIM DIAGRAM****HITCH WEIGHT: 21 LBS.****INSTALL TIME****PROFESSIONAL: 35 MINUTES****NOVICE (DIY): 70 MINUTES****INSTALL NOTES:**

- ENLARGE EXISTING HOLES
- LOWER EXHAUST
- REVERSE FISHWIRE HARDWARE

INSTALLATION STEPS

1. If present, remove (10) fasteners and lower underbody panel.
2. Lower exhaust by removing rubber isolators from muffler hangers. (See Rubber Isolator Removal Diagram.)
3. Mark and trim underbody panel. **Note:** Dimensions are approximate, confirm fit prior to trimming. Use ribs of the underbody panel as cutting guides. (See underbody panel trim diagram)
4. Enlarge existing hole in both frame rails to allow access for 1.00 X 3.00 spacers to be inserted as shown above.
5. Reverse fishwire carriage bolts and blocks into frame rails.
6. Raise hitch into position. If underbody panel is present you will need to raise it with the hitch.
7. Loosely install tow hook attachment bolt and spacers.
8. Level hitch and install tow loop attachment fasteners and tighten. This must be done to prevent the receiver tube from angling up when other fasteners are tightened.
9. Loosely install hex flange nuts.
10. Torque all 7/16" hardware to 70 lb-ft. Torque all 1/2" hardware to 110 lb-ft.
11. If present, reattach underbody panel using fasteners removed in Step (1)
12. Raise exhaust back into position and re-install rubber isolators removed in Step 1.

**PERIODICALLY CHECK THIS RECEIVER HITCH TO ENSURE THAT ALL FASTENERS
ARE TIGHT AND THAT ALL STRUCTURAL COMPONENTS ARE SOUND.****Scan
for more
information**

CURT Manufacturing LLC., warrants this product to be free of defects in material and/or workmanship at the time of retail purchase by the original purchaser. If the product is found to be defective, CURT Manufacturing LLC., may repair or replace the product, at their option, when the product is returned, prepaid, with proof of purchase. Alteration to, misuse of, or improper installation of this product voids the warranty. CURT Manufacturing LLC.'s liability is limited to repair or replacement of products found to be defective, and specifically excludes liability for incidental or consequential loss or damage.

This product complies with safety specifications and requirements for connecting devices and towing systems of the state of New York, V.E.S.C.Regulation V-5 and SAE J684.