

GROSS LOAD CAPACITY WHEN USED AS A WEIGHT CARRYING HITCH: 3,500 LBS. TRAILER WEIGHT & 350 LBS. TONGUE WEIGHT.

**\*\*\*DO NOT EXCEED VEHICLE MANUFACTURER'S RECOMMENDED TOWING CAPACITY.\*\*\***

**WARNING: ALL NON-TRAILER LOADS APPLIED TO THIS PRODUCT MUST BE SUPPORTED BY AUXILIARY STABILIZING STRAPS.**

**\*\* FAILURE TO PROPERLY SUPPORT NON-TRAILER LOADS WILL VOID PRODUCT WARRANTY\*\***

HAVING INSTALLATION QUESTIONS? CALL TECHNICAL SUPPORT AT 1-800-798-0813

Parts List			
ITEM	QTY	PART NUMBER	DESCRIPTION
1	4	M12-1.75 x 40mm	HEX BOLT
2	4	1/2"	CONICAL TOOTHED WASHER

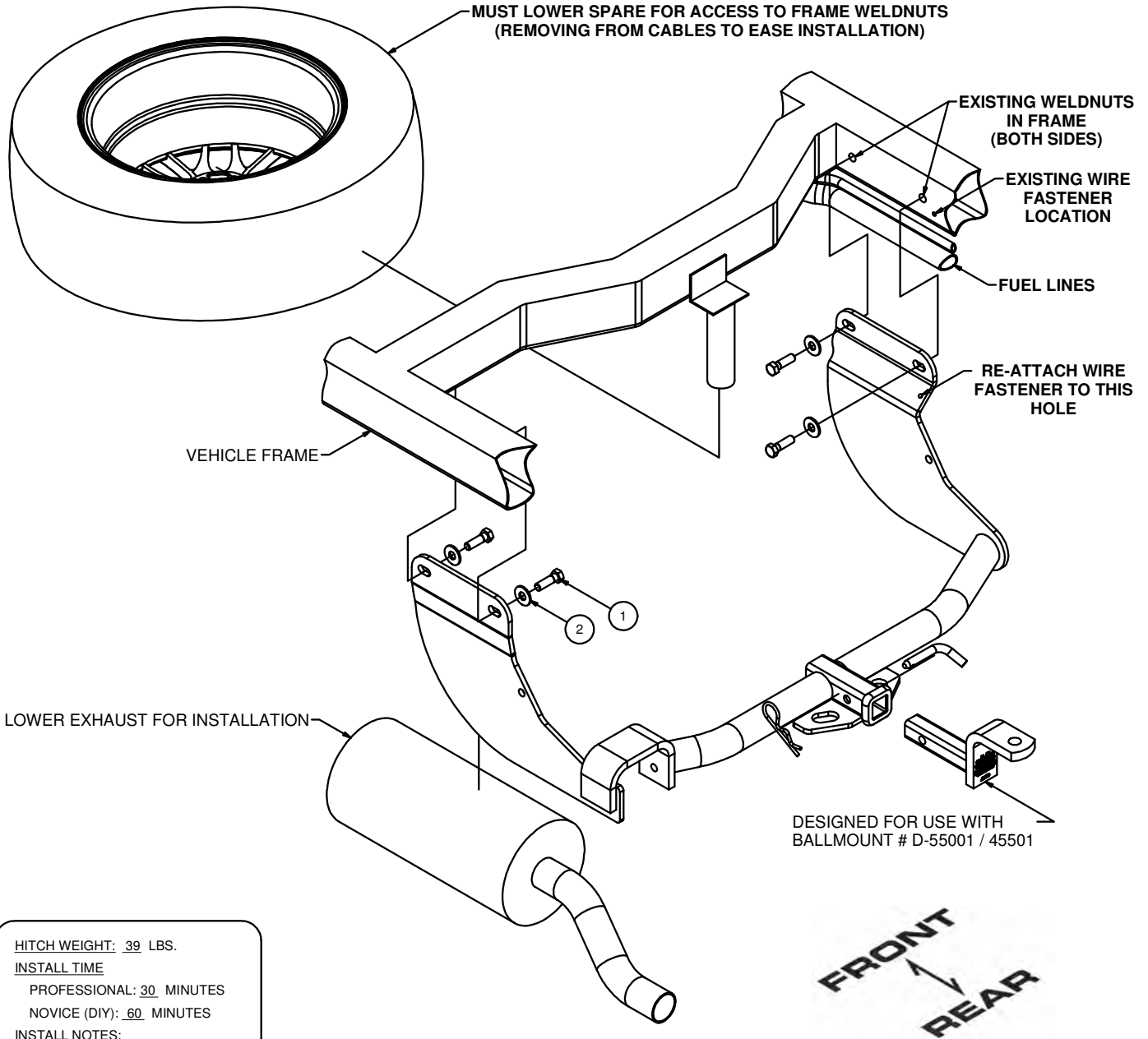

HITCH WEIGHT: 39 LBS.  
 INSTALL TIME  
 PROFESSIONAL: 30 MINUTES  
 NOVICE (DIY): 60 MINUTES  
 INSTALL NOTES:  
 - NO DRILLING REQUIRED  
 - LOWER EXHAUST  
 - LOWER SPARE TIRE

**PERIODICALLY CHECK THIS RECEIVER HITCH TO ENSURE THAT ALL FASTENERS ARE TIGHT AND THAT ALL STRUCTURAL COMPONENTS ARE SOUND.**

Curt Manufacturing Inc., warrants this product to be free of defects in material and/or workmanship at the time of retail purchase by the original purchaser. If the product is found to be defective, Curt Manufacturing Inc., may repair or replace the product, at their option, when the product is returned, prepaid, with proof of purchase. Alteration to, misuse of, or improper installation of this product voids the warranty. Curt Manufacturing Inc.'s liability is limited to repair or replacement of products found to be defective, and specifically excludes liability for incidental or consequential loss or damage.

TOOLS REQUIRED
SOCKET WRENCH
TORQUE WRENCH
19mm SOCKET
SCREW DRIVER

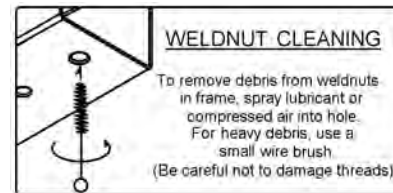
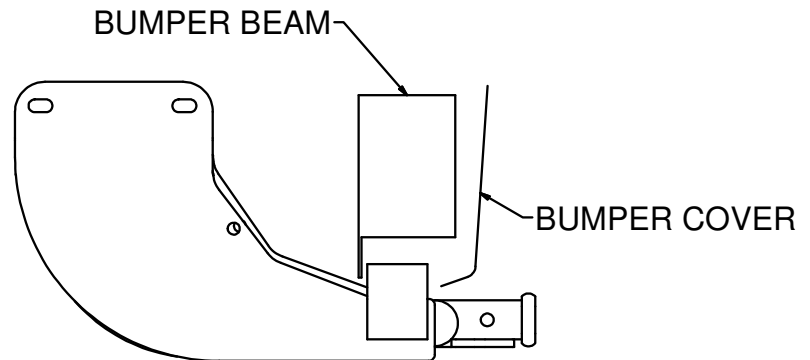
EXHAUST HANGER REMOVALINSTALLED HITCH POSITION

## INSTALLATION STEPS

- 1) Lower rearmost exhaust hanger by twisting the hanger 90° in the frame and lower through the slot in the frame. (See exhaust hanger removal image)
- 2) Lower the spare tire, to ease installation remove spare tire from vehicle. (Spare tire will be re-installed in step 7)  
  
(Note: Refer to vehicle manual for spare tire removal)
- 3) Using a screw driver, on the passenger side, pry the wire fastener from the frame rail.

**Caution:** before and while raising hitch into position, be sure not to pinch any wires or fuel lines between the hitch and the frame rails.

- 4) To raise hitch into position, raise the passenger side mounting plate up to the inside of the frame while sliding the hitch over the exhaust. Then raise the driver side mounting plate to the inside of the frame.
- 5) Loosely secure hitch with M12-1.75 hex bolts and 1/2" conical toothed washers through existing weldnuts in side of frame rails. Attach the wire fastener (removed in step 3) to passenger side mounting plate where shown.
- 6) Torque all 12mm fasteners to 79 lb-ft.
- 7) Re-install exhaust hanger (reverse of removal) and re-install spare tire (spare tire may touch hitch when fully raised).

**PERIODICALLY CHECK THIS RECEIVER HITCH TO ENSURE THAT ALL FASTENERS ARE TIGHT AND THAT ALL STRUCTURAL COMPONENTS ARE SOUND.**