



Safety glasses should be worn at all times while installing this product.

YEARS: 2013-PRESENT

MAKE: FORD

MODEL: ESCAPE

STYLE: SUV

**WARNING: NEVER EXCEED YOUR VEHICLE MANUFACTURER'S RECOMMENDED TOWING CAPACITY**

**WEIGHT CARRYING:**  
 TRAILER WEIGHT: 3,500 LBS.  
 TONGUE WEIGHT: 350 LBS.

**WARNING:**  
 WE RECOMMEND THE USE OF 18050 STABILIZING STRAPS FOR ALL NON-TRAILER (WHEEL-LESS) LOADS. PLEASE SEE THE CURT CATALOG OR VISIT US ONLINE AT [WWW.CURTMFG.COM](http://WWW.CURTMFG.COM) FOR FURTHER INFORMATION.

**PRO INSTALL TIME: 40 MIN.**  
**NOVICE INSTALL TIME: 80 MIN.**

IF YOU ARE HESITANT TO UNDERTAKE THIS TASK ON YOUR OWN, CONTACT AN AUTHORIZED CURT INSTALLER FOR ADDITIONAL ASSISTANCE.

**INSTALLATION REQUIRES:**

		6" SOCKET EXTENSION
13mm 10mm 11/16" SOCKET		AVIATION SHEARS

**INSTALLATION TIPS:**

- BEFORE YOU BEGIN INSTALLATION, READ ALL INSTRUCTIONS THOROUGHLY.
- TO EASE INSTALLATION, 2 PEOPLE MAY BE REQUIRED.
- USING PROPER TOOLS WILL GREATLY IMPROVE THE QUALITY OF THE INSTALL AND REDUCE THE TIME REQUIRED.
- NEED HELP OR HAVE SOME QUESTIONS? CALL TECHNICAL SUPPORT AT 800.798.0813

**LEVEL OF DIFFICULTY: MODERATE**

EASY	MODERATE	CHALLENGING
	- TEMPORARILY LOWER EXHAUST	
	- TRIM HEAT SHIELD	
	- FISHWIRE HARDWARE	
	- ENLARGE ACCESS HOLE	

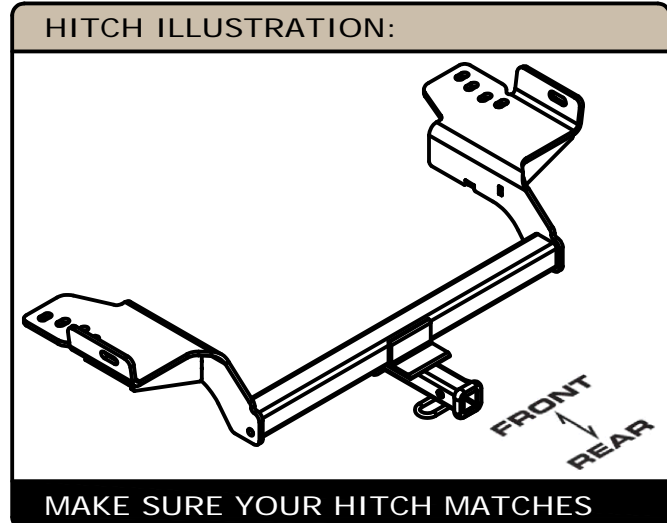

SCAN FOR MORE INFO

**PERIODICALLY CHECK THIS RECEIVER HITCH TO ENSURE ALL FASTENERS ARE TIGHT AND ALL STRUCTURAL COMPONENTS ARE SOUND**  
 CURT Manufacturing LLC. warrants this product to be free of defects in material and/or workmanship at the time of retail purchase by the original purchaser. If the product is found to be defective, CURT Manufacturing LLC. may repair or replace the product at their option, when the product is returned, prepaid, with proof of purchase. Alteration to, misuse of, or improper installation of this product voids the warranty. CURT Manufacturing LLC.'s liability is limited to repair or replacement of products found to be defective, and specifically excludes liability for incidental or consequential loss or damage. For more information log onto [www.curtmfg.com](http://www.curtmfg.com), & for helpful towing tips log onto [www.hitchinfo.com](http://www.hitchinfo.com)

# INSTALLATION WALKTHROUGH:

Parts List			
ITEM	QTY	PART NUMBER	DESCRIPTION
1	6	7_16 FISHWIRE	7/16" FISHWIRE
2	6	7/16-14 x 1 1/2	CARRIAGE BOLT
3	6	CM-SP7	.250 x 1.00 x 2.00" SQUARE HOLE SPACER
4	6	7/16-14	HEX FLANGE NUT
5	4	5/16"	WASHER
6	4	M8 - 1.25 x 30 HEX BOLT	HEX HEAD BOLT

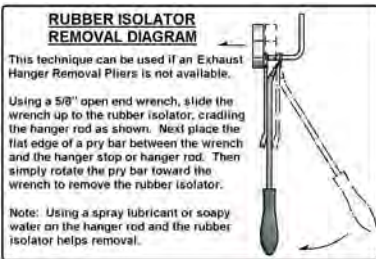
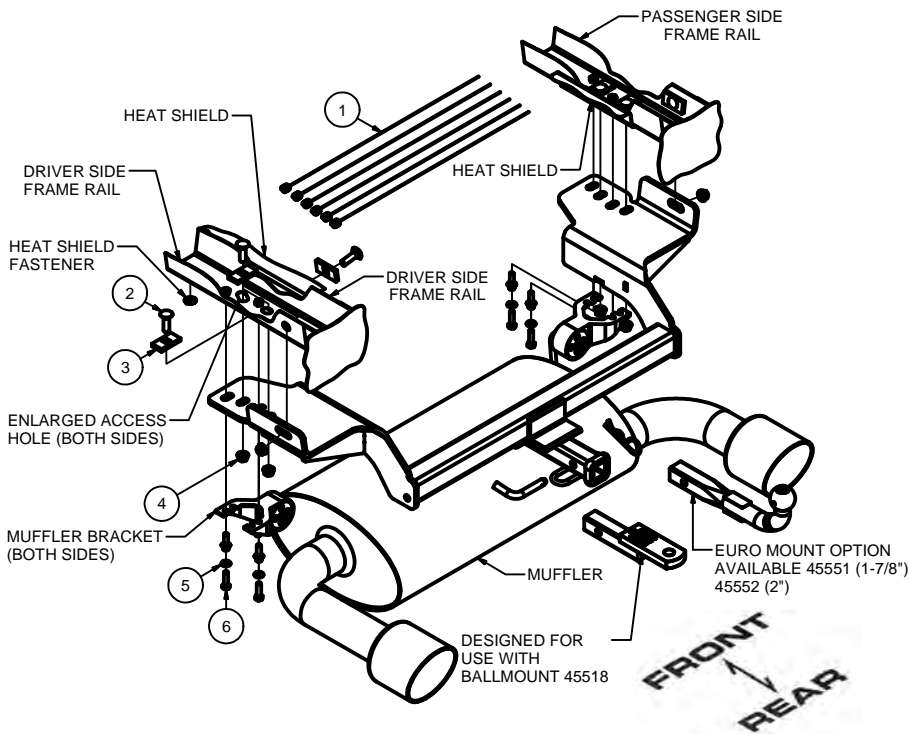

1. Lower exhaust by removing the (4) 8mm bolts from the muffler brackets and the forward rubber isolator. Return the (4) 8mm bolts to the owner.



2. Remove the (1) fastener securing the heat shield to the bottom of the driver side frame rail. Trim the portion of the heat shield covering the mounting areas of the driver and passenger side frame rails, see trim diagram. After trimming re-attach the heat shield to the bottom of the driver side.

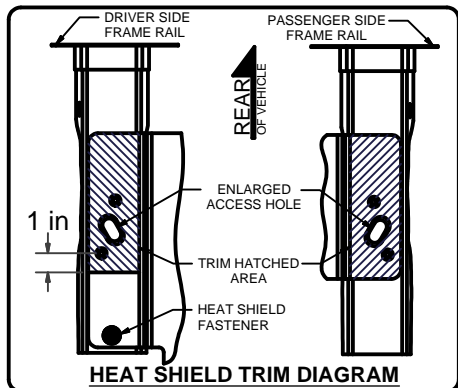

## INSTALLATION WALKTHROUGH:

3. Enlarge the access holes to allow 7/16" carriage bolts to pass through. Fishwire the 7/16" carriage bolts and SP7 spacers in the enlarged access hole and out the (2) rear-most mounting holes, both sides. Reverse fishwire the 7/16" carriage bolt and SP7 spacer in the enlarged access hole, both sides. **Note:** Leave fishwires attached to prevent loss into the frame rails. Push the side fasteners back into the frame rail prior to raising the hitch into position.

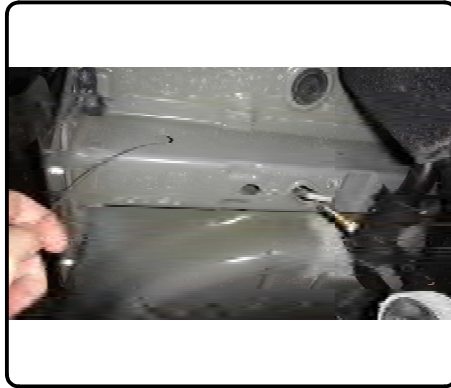

4. Slide the hitch in from the rear passenger side of the vehicle over the exhaust and into position. **Note:** Feed the fishwires through the mounting holes while raising the hitch.

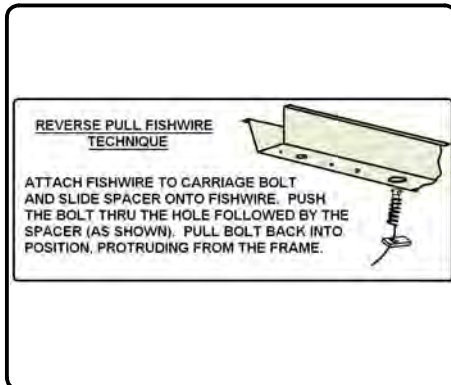
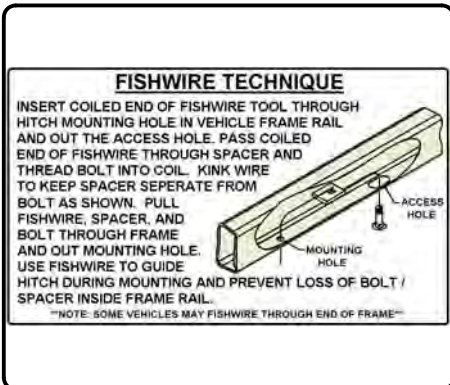

5. Remove the fishwires from the carriage bolts in the bottom of the frame rails and loosely secure the hitch with 7/16" flange nuts. Pull the fishwires through the side mounting holes and loosely secure them with 7/16" flange nuts. Re-attach the muffler brackets to the bottom of the hitch into the original mounting holes using the provided M8-1.25 hex bolts and 5/16" washers.



6. Torque all 7/16" hardware to 70 ft-lbs. Torque all M8 hardware to 23 ft-lbs. Re-attach rubber isolator removed in Step 1.

**Installation complete**



12111

# FORD ESCAPE

8/26/2014

**GROSS LOAD CAPACITY WHEN USED AS A WEIGHT CARRYING HITCH: 3,500 LBS. TRAILER WEIGHT & 350 LBS. TONGUE WEIGHT.**

\*\*\*DO NOT EXCEED VEHICLE MANUFACTURER'S RECOMMENDED TOWING CAPACITY.\*\*\*

**WARNING: ALL NON-TRAILER LOADS APPLIED TO THIS PRODUCT MUST BE SUPPORTED BY 18050 STABILIZING STRAPS.**

\*\* FAILURE TO PROPERLY SUPPORT NON-TRAILER LOADS WILL VOID PRODUCT WARRANTY\*\*

**HAVING INSTALLATION QUESTIONS? CALL TECHNICAL SUPPORT AT 1-800-798-0813**

Parts List			
ITEM	QTY	PART NUMBER	DESCRIPTION
1	6	7_16 FISHWIRE	7/16" FISHWIRE
2	6	7/16-14 x 1 1/2	CARRIAGE BOLT
3	6	CM-SP7	.250 x 1.00 x 2.00" SQUARE HOLE SPACER
4	6	7/16-14	HEX FLANGE NUT
5	4	5/16"	WASHER
6	4	M8 - 1.25 x 30 HEX BOLT	HEX HEAD BOLT

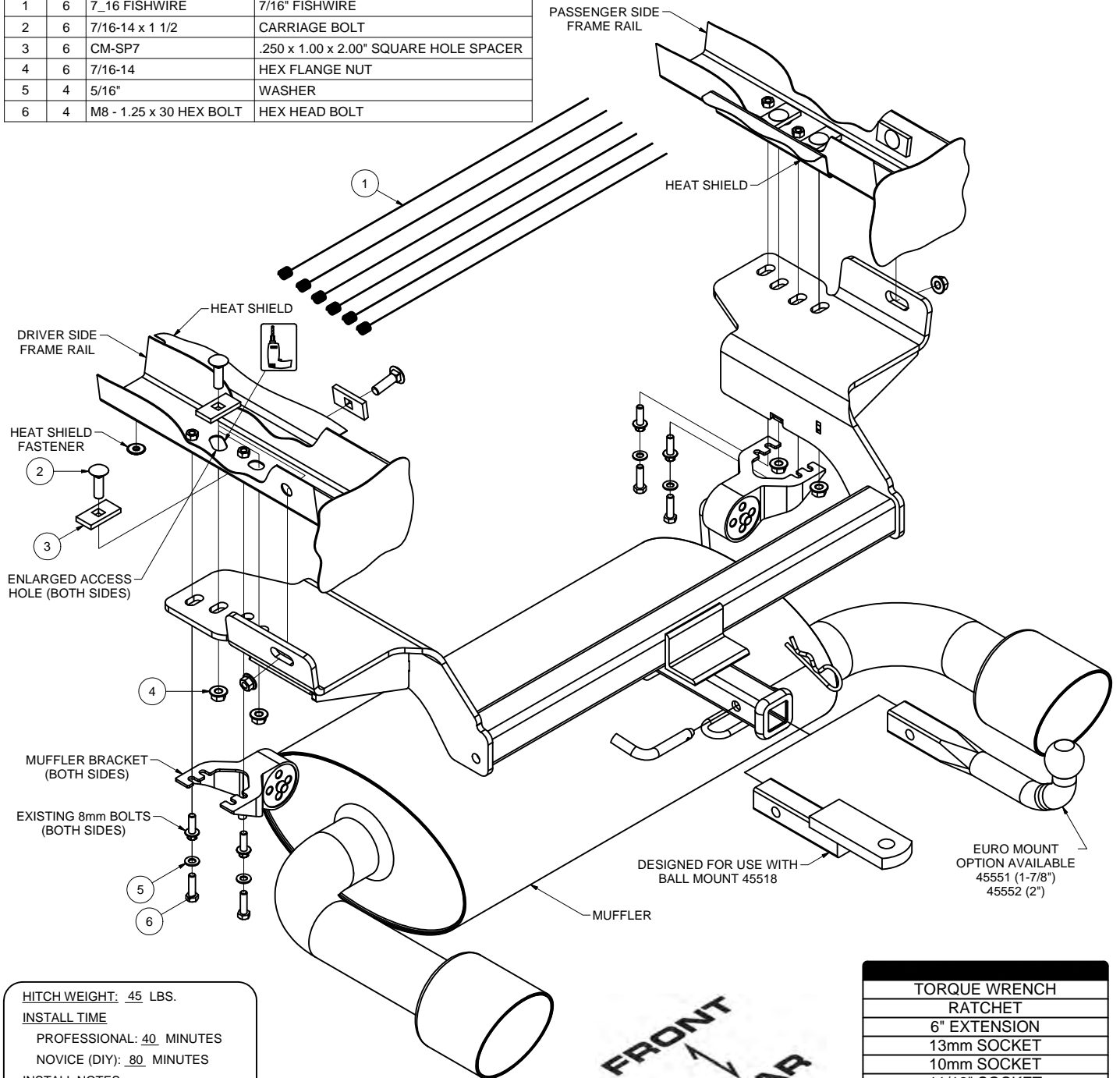

**HITCH WEIGHT: 45 LBS.**

**INSTALL TIME**

PROFESSIONAL: 40 MINUTES

NOVICE (DIY): 80 MINUTES

**INSTALL NOTES:**

- HOLE ENLARGEMENT
- FISHWIRE HARDWARE
- TRIM HEAT SHIELD
- TEMPORARILY LOWER EXHAUST

TORQUE WRENCH
RATCHET
6" EXTENSION
13mm SOCKET
10mm SOCKET
11/16" SOCKET
DIE GRINDER
SHEARS
SAFETY GLASSES

**PERIODICALLY CHECK THIS RECEIVER HITCH TO ENSURE THAT ALL FASTENERS ARE TIGHT AND THAT ALL STRUCTURAL COMPONENTS ARE SOUND.**



Scan for more information

CURT Manufacturing LLC., warrants this product to be free of defects in material and/or workmanship at the time of retail purchase by the original purchaser. If the product is found to be defective, CURT Manufacturing LLC., may repair or replace the product, at their option, when the product is returned, prepaid, with proof of purchase. Alteration to, misuse of, or improper installation of this product voids the warranty. CURT Manufacturing LLC.'s liability is limited to repair or replacement of products found to be defective, and specifically excludes liability for incidental or consequential loss or damage.



HAVING INSTALLATION QUESTIONS? CALL TECHNICAL SUPPORT AT 1-800-798-0813

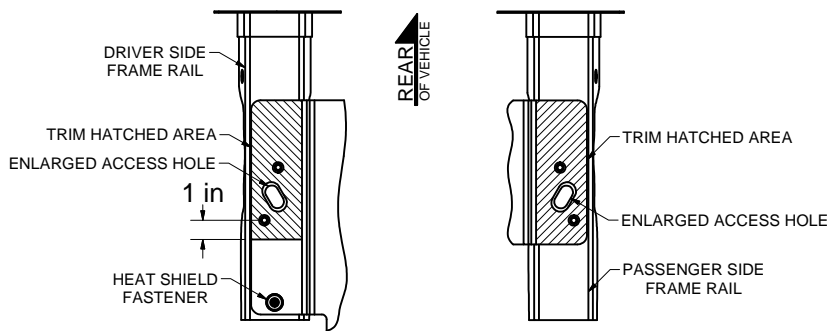

**HEAT SHIELD TRIM DIAGRAM**

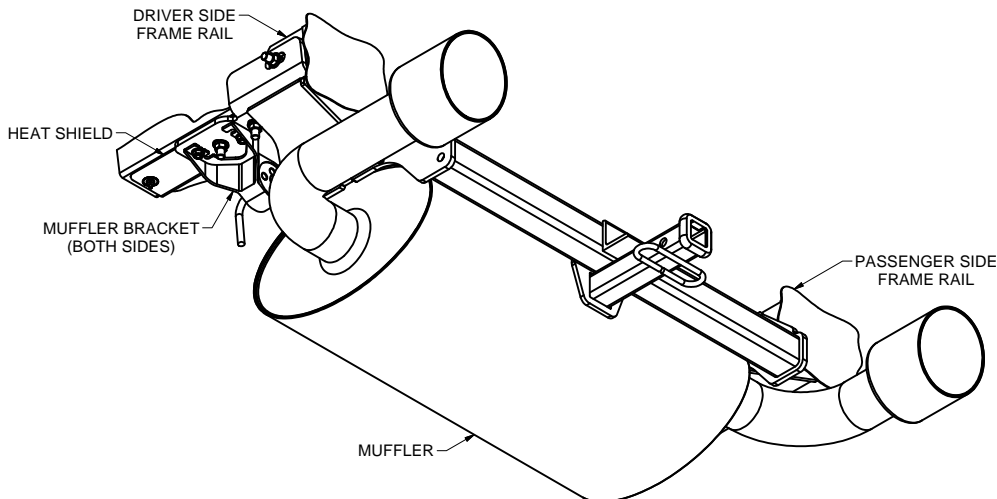

**INSTALLED HITCH**

**RUBBER ISOLATOR  
REMOVAL DIAGRAM**

This technique can be used if an Exhaust Hanger Removal Pliers is not available.

Using a 5/8" open end wrench, slide the wrench up to the rubber isolator, cradling the hanger rod as shown. Next place the flat edge of a pry bar between the wrench and the hanger stop or hanger rod. Then simply rotate the pry bar toward the wrench to remove the rubber isolator.

Note: Using a spray lubricant or soapy water on the hanger rod and the rubber isolator helps removal.

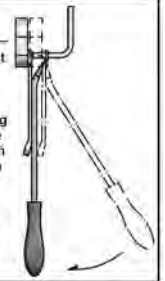

**WELDNUT CLEANING**

To remove debris from weldnuts in frame, spray lubricant or compressed air into hole. For heavy debris, use a small wire brush. (Be careful not to damage threads).

**FISHWIRE TECHNIQUE**

INSERT COILED END OF FISHWIRE TOOL THROUGH HITCH MOUNTING HOLE IN VEHICLE FRAME RAIL AND OUT THE ACCESS HOLE. PASS COILED END OF FISHWIRE THROUGH SPACER AND THREAD BOLT INTO COIL. KINK WIRE TO KEEP SPACER SEPARATE FROM BOLT AS SHOWN. PULL FISHWIRE, SPACER, AND BOLT THROUGH FRAME AND OUT MOUNTING HOLE. USE FISHWIRE TO GUIDE HITCH DURING MOUNTING AND PREVENT LOSS OF BOLT / SPACER INSIDE FRAME RAIL.

\*NOTE: SOME VEHICLES MAY FISHWIRE THROUGH END OF FRAME\*

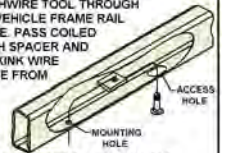

**REVERSE PULL FISHWIRE  
TECHNIQUE**

ATTACH FISHWIRE TO CARRIAGE BOLT AND SLIDE SPACER ONTO FISHWIRE. PUSH THE BOLT THRU THE HOLE FOLLOWED BY THE SPACER (AS SHOWN). PULL BOLT BACK INTO POSITION, PROTRUDING FROM THE FRAME.

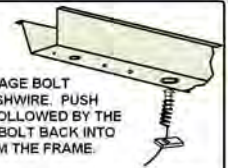

**INSTALLATION STEPS**

1. Lower exhaust by removing the (4) 8mm bolts from the muffler brackets and the forward rubber isolator. Return the (4) 8mm bolts to the owner. See Rubber Isolator Removal Diagram
2. Remove the (1) fastener securing the heat shield to the bottom of the driver side frame rail. Trim the portion of the heat shield covering the mounting areas of the driver and passenger side frame rails, see trim diagram. After trimming re-attach the heat shield to the bottom of the driver side.
3. Enlarge the access holes to allow 7/16" carriage bolts to pass through.
4. Fishwire the 7/16" carriage bolts and SP7 spacers in the enlarged access hole and out the (2) rear-most mounting holes, both sides. Reverse fishwire the 7/16" carriage bolt and SP7 spacer in the enlarged access hole, both sides. See Fishwire Diagrams. **Note:** Leave fishwires attached to prevent loss into the frame rails. Push the side fasteners back into the frame rail prior to raising the hitch into position.
5. Slide the hitch in from the rear passenger side of the vehicle over the exhaust and into position. **Note:** Feed the fishwires through the mounting holes while raising the hitch.
6. Remove the fishwires from the carriage bolts in the bottom of the frame rails and loosely secure the hitch with 7/16" flange nuts. Pull the fishwires through the side mounting holes and loosely secure them with 7/16" flange nuts.
7. Re-attach the muffler brackets to the bottom of the hitch into the original mounting holes using the provided M8-1.25 hex bolts and 5/16" washers.
8. Torque all 7/16" hardware to 70 ft-lbs. Torque all M8 hardware to 23 ft-lbs.
9. Re-attach rubber isolator removed in Step 1.

PERIODICALLY CHECK THIS RECEIVER HITCH TO ENSURE THAT ALL FASTENERS ARE TIGHT AND THAT ALL STRUCTURAL COMPONENTS ARE SOUND.

CURT Manufacturing LLC., warrants this product to be free of defects in material and/or workmanship at the time of retail purchase by the original purchaser. If the product is found to be defective, CURT Manufacturing LLC., may repair or replace the product, at their option, when the product is returned, prepaid, with proof of purchase. Alteration to, misuse of, or improper installation of this product voids the warranty. CURT Manufacturing LLC.'s liability is limited to repair or replacement of products found to be defective, and specifically excludes liability for incidental or consequential loss or damage.