



YEARS: 2017-PRESENT

MAKE: CHRYSLER

MODEL: PACIFICA

STYLE: VAN

**WARNING: NEVER EXCEED YOUR VEHICLE MANUFACTURER'S RECOMMENDED TOWING CAPACITY**  
 For more information log onto [www.curtmfg.com](http://www.curtmfg.com) & for helpful towing tips log onto [www.hitchinfo.com](http://www.hitchinfo.com)

**WEIGHT CARRYING:**  
 TRAILER WEIGHT: 3,500 LBS.  
 TONGUE WEIGHT: 350 LBS.

**WARNING:**  
 ALL NON-TRAILER (WHEEL-LESS) LOADS APPLIED TO THIS PRODUCT MUST BE SUPPORTED BY 18050 STABILIZING STRAPS. PLEASE SEE THE CURT CATALOG OR VISIT US ONLINE AT [WWW.CURTMFG.COM](http://WWW.CURTMFG.COM) FOR FURTHER INFORMATION.

**PRO INSTALL TIME: 45 MIN.**  
**NOVICE INSTALL TIME: 90 MIN.**

IF YOU ARE HESITANT TO UNDERTAKE THIS TASK ON YOUR OWN, CONTACT AN AUTHORIZED CURT INSTALLER FOR ADDITIONAL ASSISTANCE.

**INSTALLATION REQUIRES:**

RATCHET	TORQUE WRENCH	SOCKET EXTENSION 6"
SOCKET 8mm, 10mm, 3/4"	UNIVERSAL JOINT SOCKET	SCREW DRIVER
MASKING TAPE	AVIATION SHEARS	DIE GRINDER
SAFETY GLASSES		

**INSTALLATION TIPS:**

- BEFORE YOU BEGIN INSTALLATION, READ ALL INSTRUCTIONS THOROUGHLY.
- TO EASE INSTALLATION, 2 PEOPLE MAY BE REQUIRED.
- USING PROPER TOOLS WILL GREATLY IMPROVE THE QUALITY OF THE INSTALL AND REDUCE THE TIME REQUIRED.
- NEED HELP OR HAVE SOME QUESTIONS? CALL TECHNICAL SUPPORT AT 800.798.0813

**LEVEL OF DIFFICULTY: MODERATE**

EASY	MODERATE	CHALLENGING
	LOWER EXHAUST	
	TEMPORARILY REMOVE HEAT SHIELD(S)	
	TRIMMING REQUIRED	
	FISHWIRE (4) BOLTS	
	REVERSE FISHWIRE (2) BOLTS	

**VEHICLE PHOTO:**



REPRESENTATIVE PHOTO

**HITCH ILLUSTRATION:**

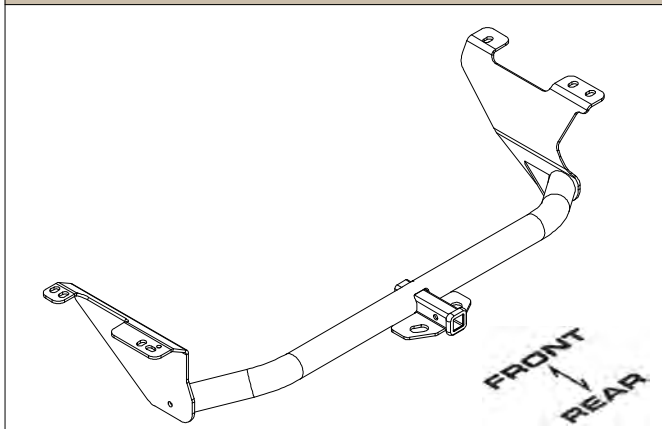

MAKE SURE YOUR HITCH MATCHES



SCAN FOR MORE INFO

**PERIODICALLY CHECK THIS RECEIVER HITCH TO ENSURE ALL FASTENERS ARE TIGHT AND ALL STRUCTURAL COMPONENTS ARE SOUND**

CURT Manufacturing LLC. warrants this product to be free of defects in material and/or workmanship at the time of retail purchase by the original purchaser. If the product is found to be defective, CURT Manufacturing LLC. may repair or replace the product at their option, when the product is returned, prepaid, with proof of purchase. Alteration to, misuse of, or improper installation of this product voids the warranty. CURT Manufacturing LLC.'s liability is limited to repair or replacement of products found to be defective, and specifically excludes liability for incidental or consequential loss or damage.

For more information log onto [www.curtmfg.com](http://www.curtmfg.com)

This product complies with safety specifications and requirements for connecting devices and towing systems of the state of New York, V.E.S.C.Regulation V-5 and SAE J684.

# INSTALLATION WALKTHROUGH:

Parts List			
ITEM	QTY	PART NUMBER	DESCRIPTION
1	5	1/2-13 x 1 1/2	CARRIAGE BOLT
2	5	CM-SP10	.250 x 1.00 x 2.50" SQUARE HOLE SPACER
3	5	1/2 CONICAL TOOTHED WASHER	WASHER, CONICAL, TOOTHED, 1/2"
4	5	HFN 1213	HEX FLANGE NUT
5	5	1_2 FISHWIRE	1/2" FISHWIRE
6	1	M6 - 1.00 X 40 TAP BOLT	TAP BOLT
7	1	1_4-20 x 1.00 HEX BOLT	1/4-20 x 1.00 HEX BOLT
8	1	1_4 - 20	HEX NUT

**FISHWIRE TECHNIQUE**

INSERT COILED END OF FISHWIRE TOOL THROUGH HITCH MOUNTING HOLE IN VEHICLE FRAME RAIL AND OUT THE ACCESS HOLE. PASS COILED END OF FISHWIRE THROUGH SPACER AND THREAD BOLT INTO COIL. KINK WIRE TO KEEP SPACER SEPARATE FROM BOLT AS SHOWN. PULL FISHWIRE, SPACER, AND BOLT THROUGH FRAME AND OUT MOUNTING HOLE. USE FISHWIRE TO GUIDE HITCH DURING MOUNTING AND PREVENT LOSS OF BOLT / SPACER INSIDE FRAME RAIL.

\*\*NOTE: SOME VEHICLES MAY FISHWIRE THROUGH END OF FRAME\*\*

**REVERSE PULL FISHWIRE TECHNIQUE**

ATTACH FISHWIRE TO CARRIAGE BOLT AND SLIDE SPACER ONTO FISHWIRE. PUSH THE BOLT THRU THE HOLE FOLLOWED BY THE SPACER (AS SHOWN). PULL BOLT BACK INTO POSITION, PROTRUDING FROM THE FRAME.

1. Locate and remove (5) screws with 8mm socket, (7) nuts with a 10mm socket, (2) bolts with a 10mm socket, and (2) plastic screws with a screwdriver. **NOTE:** if no underbody panel, skip to Step 3.



2. Locate and remove (3) screws from driver side wheel well with an 8mm socket. Remove underbody panel and mark out a 0.5" x 10" slot with masking tape. Use aviation shears to trim underbody panel. Set aside for later reinstallation.

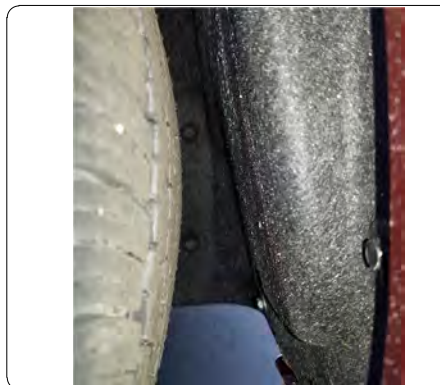

## INSTALLATION WALKTHROUGH:

3. Lower exhaust by removing (2) rubber isolators.  
(See Rubber Isolator Removal Diagram on previous page)



4. Locate and remove (2) plastic nuts with a 10mm socket. Remove heat shield and mark out a 5" x 13" section with masking tape. Use aviation shears to trim marked area. Reinstall with (1) nut using a 10mm socket.  
**NOTE:** If no underbody panel, remove (4) plastic nuts, trim panel, and reinstall with (3) plastic nuts.

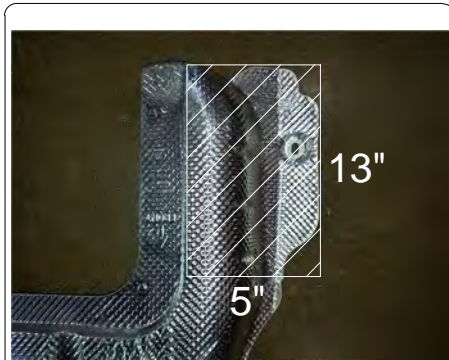
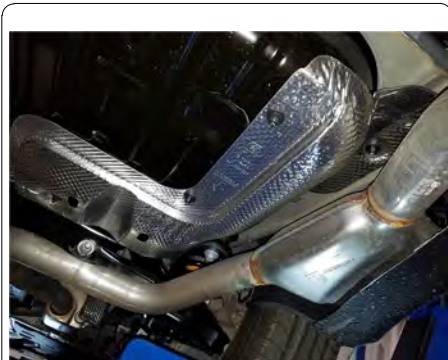

5. **On Hybrid models only:** temporarily remove emissions canister on driver side frame rail using 10mm socket to remove (2) bolts. Use provided M6 hardware to reinstall.



6. **On Hybrid models only:** enlarge holes on driver side frame rail using die grinder as shown in the Hole Enlargement Diagram



## INSTALLATION WALKTHROUGH:

7. Fishwire (1) 1/2" carriage bolt and (1) CM-SP10 spacer in the rear most holes of driver side frame rail through the access hole. Fishwire (2) 1/2" carriage bolts and (2) CM-SP10 spacers in the rear most holes of passenger side frame rail through the access hole. Reverse Fishwire (1) 1/2" carriage bolt and (1) CM-SP10 spacer into the access hole on each frame rail.

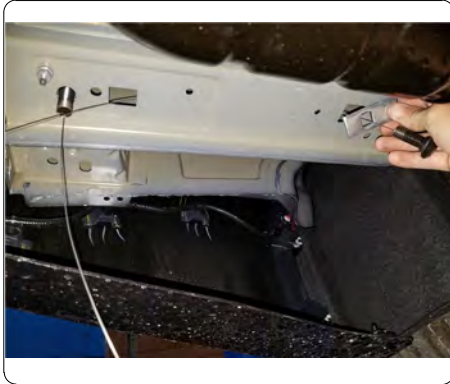

8. On driver side frame rail locate and remove (1) nut using 10mm socket.  
**NOTE:** If electrical ground is present relocate using provided 1/4" hardware. Assure the area is free of rust, dirt and paint.



9. Raise hitch into position starting with the passenger side. Run the fishwires through the holes on hitch to help align bolts with hitch holes. Remove fishwires and loosely fasten (2) 1/2" hex flange nuts on driver side and (3) 1/2" hex flange nuts on passenger side.

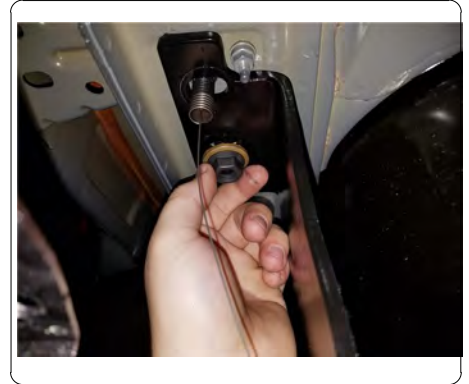
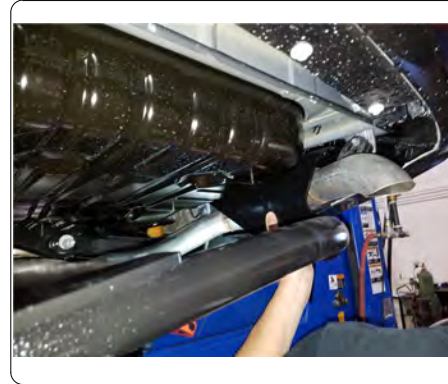

10. Torque all 1/2" hardware to 110 ft-lbs. Reinstall Underbody panel following steps 1 and 2 in reverse order.



## TOWING SAFETY INFORMATION

### Gross Trailer Weight / GTW

The Gross Trailer Weight is the weight of the trailer & cargo. Measure this by putting the fully loaded trailer on a vehicle scale.



### Tongue Weight / TW

The downward force that is exerted on the hitch ball by the coupler. The tongue weight will vary depending on where the load is positioned in relationship to the trailer axle(s). To measure the tongue weight, use either a commercial scale or a bathroom scale with the coupler at towing height. When using a bathroom scale with heavier tongue weights, use the method shown and multiply the scale reading by 3.

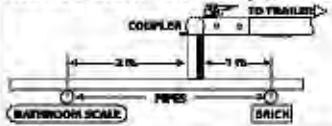

### Weight Carrying / WC

The total weight of both the trailer and the cargo inside. Never exceed the weight capacity of your trailer hitch.

### Weight Distribution / WD

Used to balance the weight of the cargo between the front and rear wheels throughout the trailer, allowing for better steering, braking, and level riding.



### Sway Control

A device used to reduce the lateral movements of the trailer that are caused by the wind. This works in conjunction with a weight distribution hitch. Do not use this on a class 1 or 2 hitch, or with surge brakes.

### How Much Can You Safely Tow?

TONGUE WEIGHT		TONGUE WEIGHT SHOULD BE ABOUT 10 TO 15 PERCENT OF THE GROSS TRAILER WEIGHT												
TRAILER TYPE		CLASS 1					CLASS 2							
Coupler		CLASS 3												
1/2" Coupler	1100	1200	1300	1400	1500	1600								
3/4" Coupler	2100	2400	2700	3000	3300	3600	3900	4200	4500	4800				
1" Coupler	2800	3200	3600	4000	4400	4800	5200	5600	6000	6400				
1 1/2" Coupler														
2" Coupler														
2 1/2" Coupler														
3" Coupler														
3 1/2" Coupler														
4" Coupler														
4 1/2" Coupler														
5" Coupler														
5 1/2" Coupler														
6" Coupler														
6 1/2" Coupler														
7" Coupler														
7 1/2" Coupler														
8" Coupler														
8 1/2" Coupler														
9" Coupler														
9 1/2" Coupler														
10" Coupler														
10 1/2" Coupler														
11" Coupler														
11 1/2" Coupler														
12" Coupler														
12 1/2" Coupler														
13" Coupler														
13 1/2" Coupler														
14" Coupler														
14 1/2" Coupler														
15" Coupler														
15 1/2" Coupler														
16" Coupler														
16 1/2" Coupler														
17" Coupler														
17 1/2" Coupler														
18" Coupler														
18 1/2" Coupler														
19" Coupler														
19 1/2" Coupler														
20" Coupler														
20 1/2" Coupler														
21" Coupler														
21 1/2" Coupler														
22" Coupler														
22 1/2" Coupler														
23" Coupler														
23 1/2" Coupler														
24" Coupler														
24 1/2" Coupler														
25" Coupler														
25 1/2" Coupler														
26" Coupler														
26 1/2" Coupler														
27" Coupler														
27 1/2" Coupler														
28" Coupler														
28 1/2" Coupler														
29" Coupler														
29 1/2" Coupler														
30" Coupler														
30 1/2" Coupler														
31" Coupler														
31 1/2" Coupler														
32" Coupler														
32 1/2" Coupler														
33" Coupler														
33 1/2" Coupler														
34" Coupler														
34 1/2" Coupler														
35" Coupler														
35 1/2" Coupler														
36" Coupler														
36 1/2" Coupler														
37" Coupler														
37 1/2" Coupler														
38" Coupler														
38 1/2" Coupler														
39" Coupler														
39 1/2" Coupler														
40" Coupler														
40 1/2" Coupler														
41" Coupler														
41 1/2" Coupler														
42" Coupler														
42 1/2" Coupler														
43" Coupler														
43 1/2" Coupler														
44" Coupler														
44 1/2" Coupler														
45" Coupler														
45 1/2" Coupler														
46" Coupler														
46 1/2" Coupler														
47" Coupler														
47 1/2" Coupler														
48" Coupler														
48 1/2" Coupler														
49" Coupler														
49 1/2" Coupler														
50" Coupler														
50 1/2" Coupler														
51" Coupler														
51 1/2" Coupler														
52" Coupler														
52 1/2" Coupler														
53" Coupler														
53 1/2" Coupler														
54" Coupler														
54 1/2" Coupler														
55" Coupler														
55 1/2" Coupler														
56" Coupler														
56 1/2" Coupler														
57" Coupler														
57 1/2" Coupler														
58" Coupler														
58 1/2" Coupler														
59" Coupler														
59 1/2" Coupler														
60" Coupler														
60 1/2" Coupler														
61" Coupler														
61 1/2" Coupler														
62" Coupler														

GROSS LOAD CAPACITY WHEN USED AS A WEIGHT CARRYING HITCH: 3,500 LBS. TRAILER WEIGHT & 350 LBS. TONGUE WEIGHT.

WARNING: ALL NON-TRAILER (WHEEL-LESS) LOADS APPLIED TO THIS PRODUCT MUST BE SUPPORTED BY 18050 STABILIZING STRAPS.

WARNING: \*\* FAILURE TO PROPERLY SUPPORT NON-TRAILER LOADS WILL VOID PRODUCT WARRANTY \*\*

WARNING: \*\*\* DO NOT EXCEED VEHICLE MANUFACTURER'S RECOMMENDED TOWING CAPACITY \*\*\*

FOR MORE INFORMATION LOG ONTO WWW.CURTMFG.COM

HAVING INSTALLATION QUESTIONS? CALL TECHNICAL SUPPORT AT 1-800-798-0813



Parts List			
ITEM	QTY	PART NUMBER	DESCRIPTION
1	5	1/2-13 x 1 1/2	CARRIAGE BOLT
2	5	CM-SP10	.250 x 1.00 x 2.50" SQUARE HOLE SPACER
3	5	1/2 CONICAL TOOTHED WASHER	WASHER, CONICAL, TOOTHED, 1/2"
4	5	HFN 1213	HEX FLANGE NUT
5	5	1_2 FISHWIRE	1/2" FISHWIRE
6	1	M6 - 1.00 X 40 TAP BOLT	TAP BOLT
7	1	1_4-20 x 1.00 HEX BOLT	1/4-20 x 1.00 HEX BOLT
8	1	1_4 - 20	HEX NUT

TOOLS REQUIRED
RATCHET
TORQUE WRENCH
6" SOCKET EXTENSION
8mm, 10mm, 3/4" SOCKETS
UNIVERSAL JOINT SOCKET
SCREWDRIVER
MASKING TAPE
AVIATION SHEARS
DIE GRINDER
SAFETY GLASSES

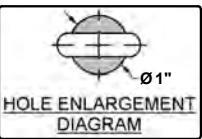
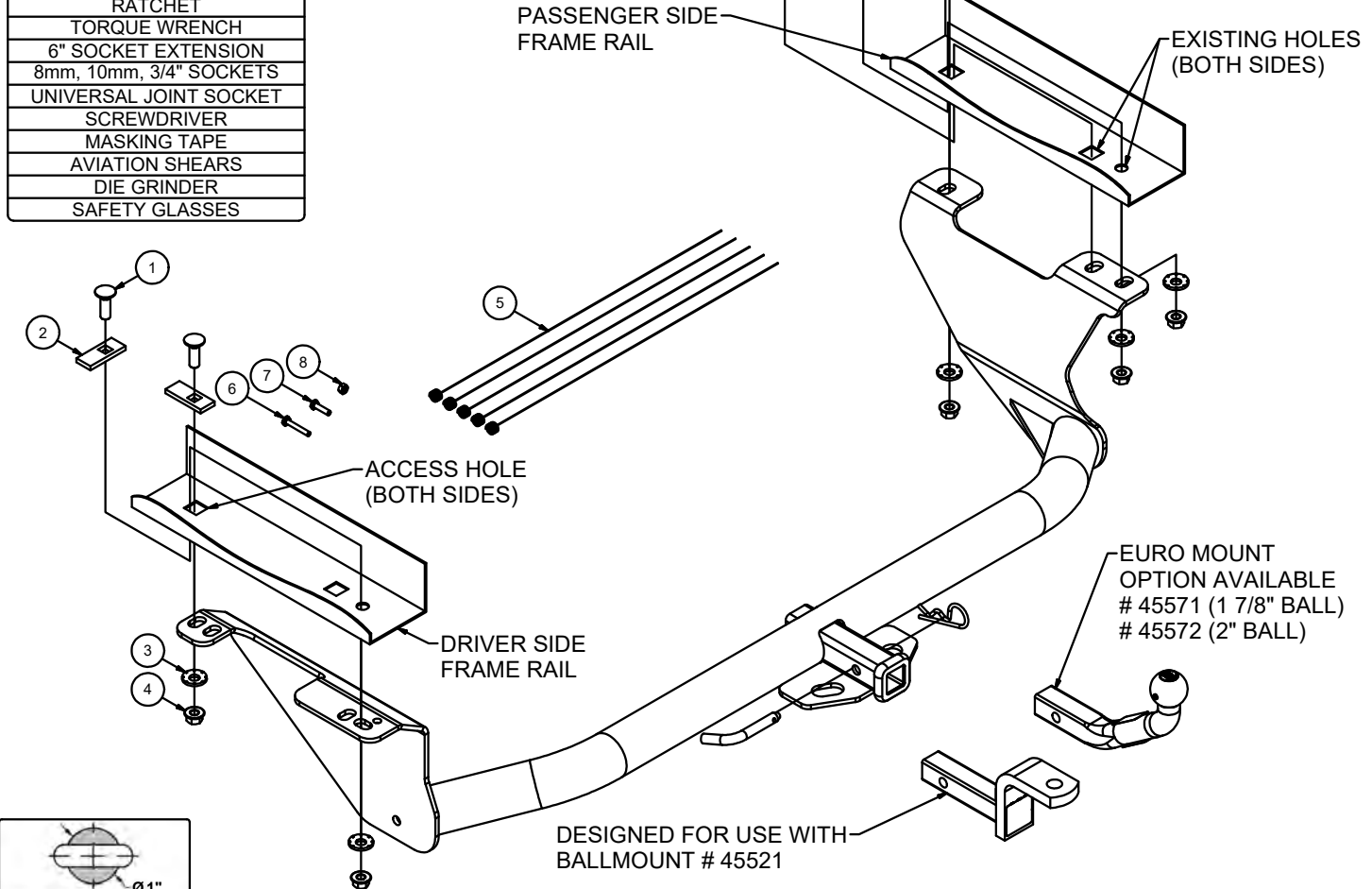
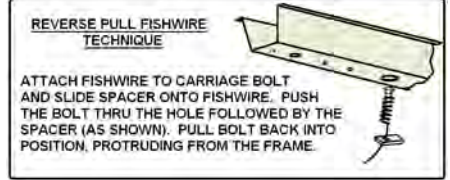

HITCH WEIGHT: 39 LBS.  
 INSTALL TIME  
 PROFESSIONAL: 45 MINUTES  
 NOVICE (DIY): 90 MINUTES  
 INSTALL NOTES:  
 -LOWER EXHAUST  
 -REMOVE HEAT SHIELD(S)  
 -TRIM HEAT SHIELD  
 -TRIM UNDERBODY PANEL

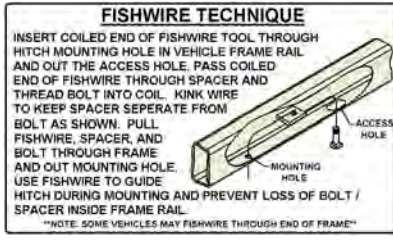

PERIODICALLY CHECK THIS RECEIVER HITCH TO ENSURE THAT ALL FASTENERS ARE TIGHT AND THAT ALL STRUCTURAL COMPONENTS ARE SOUND.



Scan for more information

CURT Manufacturing LLC., warrants this product to be free of defects in material and/or workmanship at the time of retail purchase by the original purchaser. If the product is found to be defective, CURT Manufacturing LLC., may repair or replace the product, at their option, when the product is returned, prepaid, with proof of purchase. Alteration to, misuse of, or improper installation of this product voids the warranty. CURT Manufacturing LLC.'s liability is limited to repair or replacement of products found to be defective, and specifically excludes liability for incidental or consequential loss or damage.

This product complies with safety specifications and requirements for connecting devices and towing systems of the state of New York, V.E.S.C.Regulation V-5 and SAE J684.

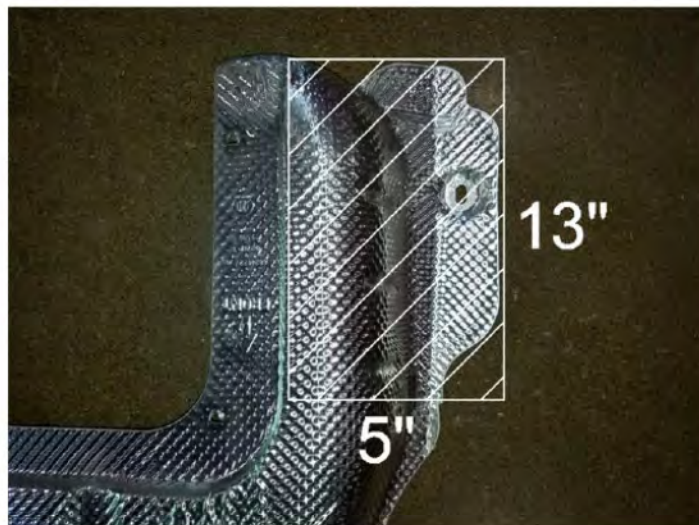
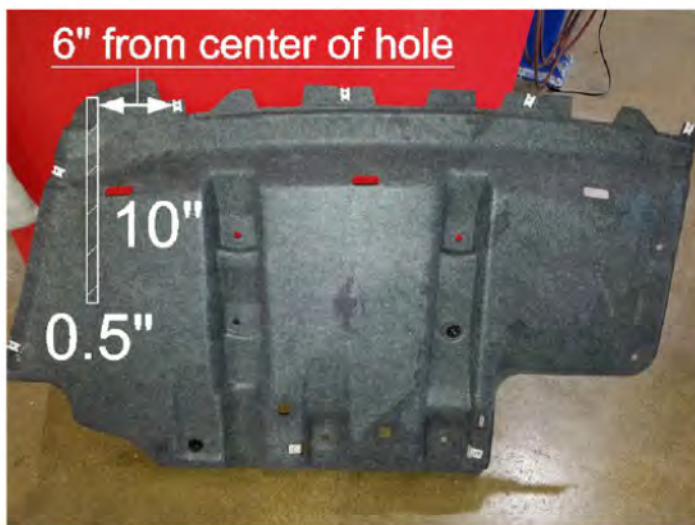

### INSTALLATION STEPS

1. Locate and remove (5) screws with 8mm socket, (7) nuts with a 10mm socket, (2) bolts with a 10mm socket, and (2) plastic screws with a screwdriver. **NOTE:** If no underbody panel, skip to Step 3.
2. Locate and remove (3) screws from driver side wheel well with a 8mm socket. Remove underbody panel and mark out a 0.5" x 10" slot with masking tape. Use aviation shears to trim underbody panel. Set aside for later reinstallation.
3. Lower exhaust by removing (2) rubber isolators. (See Rubber Removal Isolator Diagram on previous page)
4. Locate and remove (2) plastic nuts with a 10mm socket. Remove heat shield and mark out a 5" x 13" section with masking tape. Use aviation shears to trim marked area. Reinstall with (1) nut using a 10mm socket. **NOTE:** if no underbody panel, instead remove (4) plastic nuts, trim panel, and reinstall with (3) plastic nuts.
5. **On Hybrid models only:** temporarily remove emissions cannister on driver side frame rail using 10mm socket.
6. **On Hybrid models only:** Enlarge holes on driver side frame rail using die grinder as shown in the Hole Enlargement Diagram
7. Fishwire (1) 1/2" carriage bolt and (1) CM-SP10 spacer in the rear most hole of the frame rail through the access hole on driver side frame rail. Fishwire (3) 1/2" carriage bolts and (2) CM-SP10 spacers in the rear most hole of the frame rail through the access hole on passenger side frame rail. Reverse Fishwire (1) 1/2" carriage bolt and (1) CM-SP10 spacer into the access hole on each frame rail.
8. On driver side frame rail locate and remove (1) nut using 10mm socket. **NOTE:** If electrical ground is present relocate using provided 1/4" hardware. Assure the area is free of rust, dirt and paint.
9. Raise hitch into position starting with the passenger side. Run the fishwires through the holes on hitch to help align bolts with hitch holes. Remove fishwires and loosely fasten (2) 1/2" hex flange nuts on driver side and (2) 1/2" hex flange nuts on driver side
10. Torque all 1/2" hardware to 110 ft-lbs. Reinstall underbody panel following Steps 1 and 2 in reverse order.

PERIODICALLY CHECK THIS RECEIVER HITCH TO ENSURE THAT ALL FASTENERS ARE TIGHT AND THAT ALL STRUCTURAL COMPONENTS ARE SOUND.