

# 13063 CHEVROLET / GMC 2500 / 3500 SHORT AND LONG BED

10/19/2012

GROSS LOAD CAPACITY WHEN USED AS A WEIGHT CARRYING HITCH: 8,000 LBS. TRAILER WEIGHT & 800 LBS. TONGUE WEIGHT.  
 GROSS LOAD CAPACITY WHEN USED AS A WEIGHT DISTRIBUTION HITCH: 12,000 LBS. TRAILER WEIGHT & 1,200 LBS. TONGUE WEIGHT

**\*\*\*DO NOT EXCEED VEHICLE MANUFACTURER'S RECOMMENDED TOWING CAPACITY.\*\*\***

HAVING INSTALLATION QUESTIONS? CALL TECHNICAL SUPPORT AT 1-800-798-0813

Parts List				
ITEM	QTY	PART NUMBER	DESCRIPTION	
1	4	9/16" CONICAL WASHER	CONICAL TOOTHED WASHER	
2	4	M14 - 2 x 45 HEX	HEX BOLT	
3	2	1/2-13 x 1 3/4	CARRIAGE BOLT	
4	2	HFN 1213	HEX FLANGE NUT	
5	2	CM-SP1	.250 x 1.50 x 2.00" SQUARE HOLE SPACER	

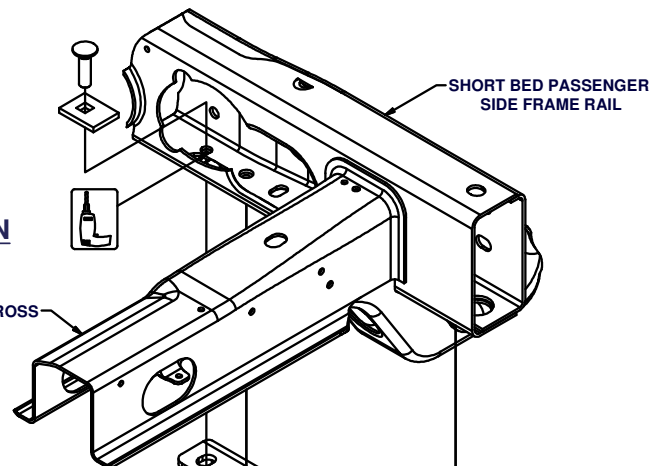

## SHORT BED INSTALLATION

## LONG BED INSTALLATION

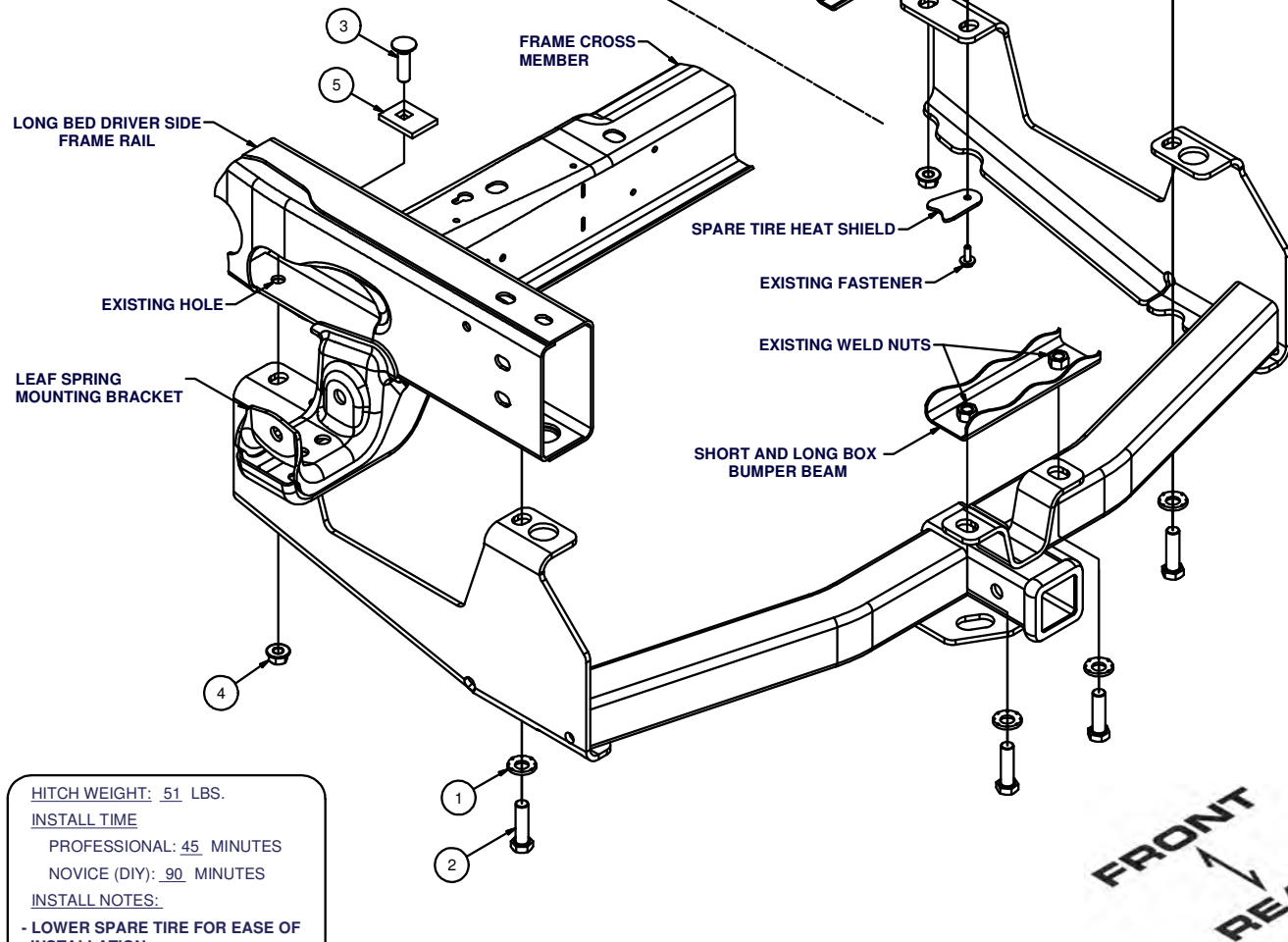

HITCH WEIGHT: 51 LBS.

INSTALL TIME

PROFESSIONAL: 45 MINUTES

NOVICE (DIY): 90 MINUTES

INSTALL NOTES:

- LOWER SPARE TIRE FOR EASE OF INSTALLATION
- DRILLING REQUIRED (SHORT BED)

**PERIODICALLY CHECK THIS RECEIVER HITCH TO ENSURE THAT ALL FASTENERS ARE TIGHT AND THAT ALL STRUCTURAL COMPONENTS ARE SOUND.**

Curt Manufacturing Inc., warrants this product to be free of defects in material and/or workmanship at the time of retail purchase by the original purchaser. If the product is found to be defective, Curt Manufacturing Inc., may repair or replace the product, at their option, when the product is returned, prepaid, with proof of purchase. Alteration to, misuse of, or improper installation of this product voids the warranty. Curt Manufacturing Inc.'s liability is limited to repair or replacement of products found to be defective, and specifically excludes liability for incidental or consequential loss or damage.

# 13063 CHEVROLET / GMC 2500 / 3500 SHORT AND LONG BED

10/19/2012

**\*\*\*DO NOT EXCEED VEHICLE MANUFACTURER'S RECOMMENDED TOWING CAPACITY.\*\*\***

HAVING INSTALLATION QUESTIONS? CALL TECHNICAL SUPPORT AT 1-800-798-0813

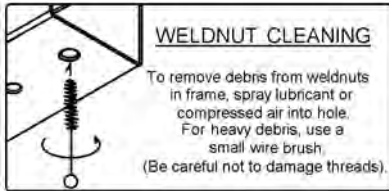

TOOLS REQUIRED
RATCHET
TORQUE WRENCH
10" EXTENSION
21mm SOCKET
3/4" SOCKET
13mm SOCKET
17/32" DRILL BIT
DRILL

## INSTALLATION STEPS

### LONG BED INSTALLATION

1. Lower spare tire for ease of installation.
2. Remove existing 14mm fasteners from end of each frame rail if present and return to vehicle owner.
3. Raise hitch into position, locating slots in hitch over weldnuts in vehicle frame.
4. Install 14mm fasteners and 9/16" conical toothed washers through hitch into weldnuts in vehicle frame and bumper.
5. Install 1/2" fasteners, CM-SP1 spacers and hex flange nuts through existing hole, as shown.
6. Torque all 14mm fasteners to 126 ft-lbs, and all 1/2" fasteners to 110 ft-lbs.

### SHORT BED INSTALLATION

1. Lower spare tire for ease of installation.
2. Remove existing 14mm fasteners from end of each frame rail if present and return to vehicle owner.
3. Remove existing 7mm fastener holding rear of spare tire heat shield of passenger side of vehicle. Retain fastener for reinstallation
4. Raise hitch into position, locating slots in hitch over weldnuts in vehicle frame. The passenger hitch side plate will be sandwiched between the spare tire heat shield and frame rail.
5. Install 14mm fasteners and 9/16" conical toothed washers through hitch into weldnuts in vehicle frame and bumper.
6. Reinstall spare tire heat shield fastener.
7. Using hitch as a template, drill front hole for 1/2" fasteners on driver and passenger side of vehicle.
8. Install 1/2" fasteners, CM-SP1 spacers and hex flange nuts through drilled hole, as shown.
9. Torque all 14mm fasteners to 126 ft-lbs, and all 1/2" fasteners to 110 ft-lbs. and 7mm fastener to 16 ft-lbs.

**PERIODICALLY CHECK THIS RECEIVER HITCH TO ENSURE THAT ALL FASTENERS ARE TIGHT AND THAT ALL STRUCTURAL COMPONENTS ARE SOUND.**

Curt Manufacturing Inc., warrants this product to be free of defects in material and/or workmanship at the time of retail purchase by the original purchaser. If the product is found to be defective, Curt Manufacturing Inc., may repair or replace the product, at their option, when the product is returned, prepaid, with proof of purchase. Alteration to, misuse of, or improper installation of this product voids the warranty. Curt Manufacturing Inc.'s liability is limited to repair or replacement of products found to be defective, and specifically excludes liability for incidental or consequential loss or damage.