



Safety glasses should be worn at all times while installing this product.

YEARS: 2018-PRESENT

MAKE: BMW

MODEL: X3

STYLE: SUV

WARNING: NEVER EXCEED YOUR VEHICLE MANUFACTURER'S RECOMMENDED TOWING CAPACITY
 For more information log onto www.curtmfg.com & for helpful towing tips log onto www.hitchinfo.com

WEIGHT CARRYING:
 TRAILER WEIGHT: 5,000 LBS.
 TONGUE WEIGHT: 750 LBS.

WARNING:
 ALL NON-TRAILER (WHEEL-LESS) LOADS APPLIED TO THIS PRODUCT MUST BE SUPPORTED BY 18050 STABILIZING STRAPS. PLEASE SEE THE CURT CATALOG OR VISIT US ONLINE AT WWW.CURTMFG.COM FOR FURTHER INFORMATION.

PRO INSTALL TIME: 90 MIN.
NOVICE INSTALL TIME: 180 MIN.

IF YOU ARE HESITANT TO UNDERTAKE THIS TASK ON YOUR OWN, CONTACT AN AUTHORIZED CURT INSTALLER FOR ADDITIONAL ASSISTANCE.

- INSTALLATION TIPS:**
- BEFORE YOU BEGIN INSTALLATION, READ ALL INSTRUCTIONS THOROUGHLY.
 - TO EASE INSTALLATION, 2 PEOPLE MAY BE REQUIRED.
 - USING PROPER TOOLS WILL GREATLY IMPROVE THE QUALITY OF THE INSTALL AND REDUCE THE TIME REQUIRED.
 - NEED HELP OR HAVE SOME QUESTIONS? CALL TECHNICAL SUPPORT AT 800.798.0813



INSTALLATION REQUIRES:

LEVEL OF DIFFICULTY: CHALLENGING

EASY	MODERATE	CHALLENGING
	REMOVE BUMPER AND EXHAUST HANGERS	
	TRIM UNDERBODY PANEL	
	NO DRILLING REQUIRED	

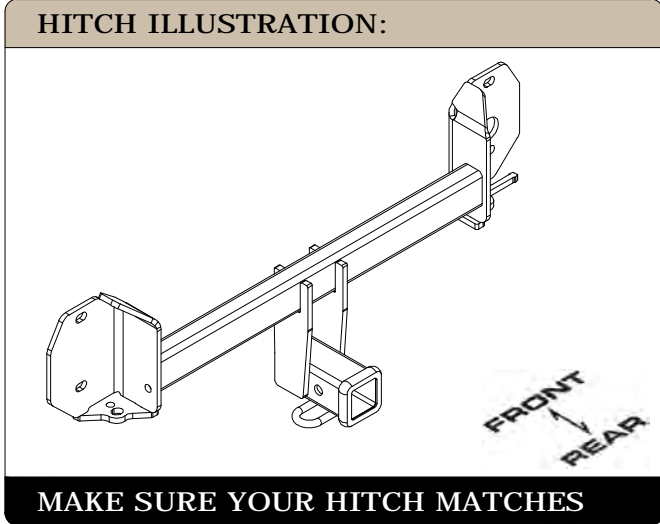

PERIODICALLY CHECK THIS RECEIVER HITCH TO ENSURE ALL FASTENERS ARE TIGHT AND ALL STRUCTURAL COMPONENTS ARE SOUND
 CURT Manufacturing LLC. warrants this product to be free of defects in material and/or workmanship at the time of retail purchase by the original purchaser. If the product is found to be defective, CURT Manufacturing LLC. may repair or replace the product at their option, when the product is returned, prepaid, with proof of purchase. Alteration to, misuse of, or improper installation of this product voids the warranty. CURT Manufacturing LLC.'s liability is limited to repair or replacement of products found to be defective, and specifically excludes liability for incidental or consequential loss or damage.
 For more information log onto www.curtmfg.com
 This product complies with safety specifications and requirements for connecting devices and towing systems of the state of New York, V.E.S.C.Regulation V-5 and SAE J684.

INSTALLATION WALKTHROUGH:

Parts List			
ITEM	QTY	PART NUMBER	DESCRIPTION
1	8	M6 RIVET	NYLON RIVET (AUVECO #20754)
2	1	M8-1.25 x 35	HEX BOLT

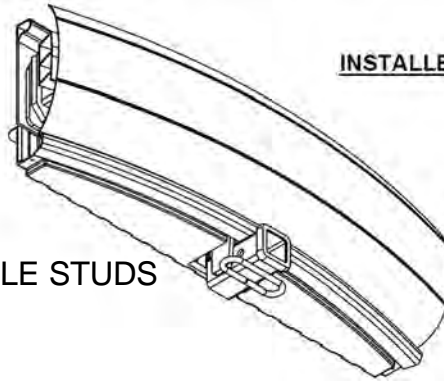
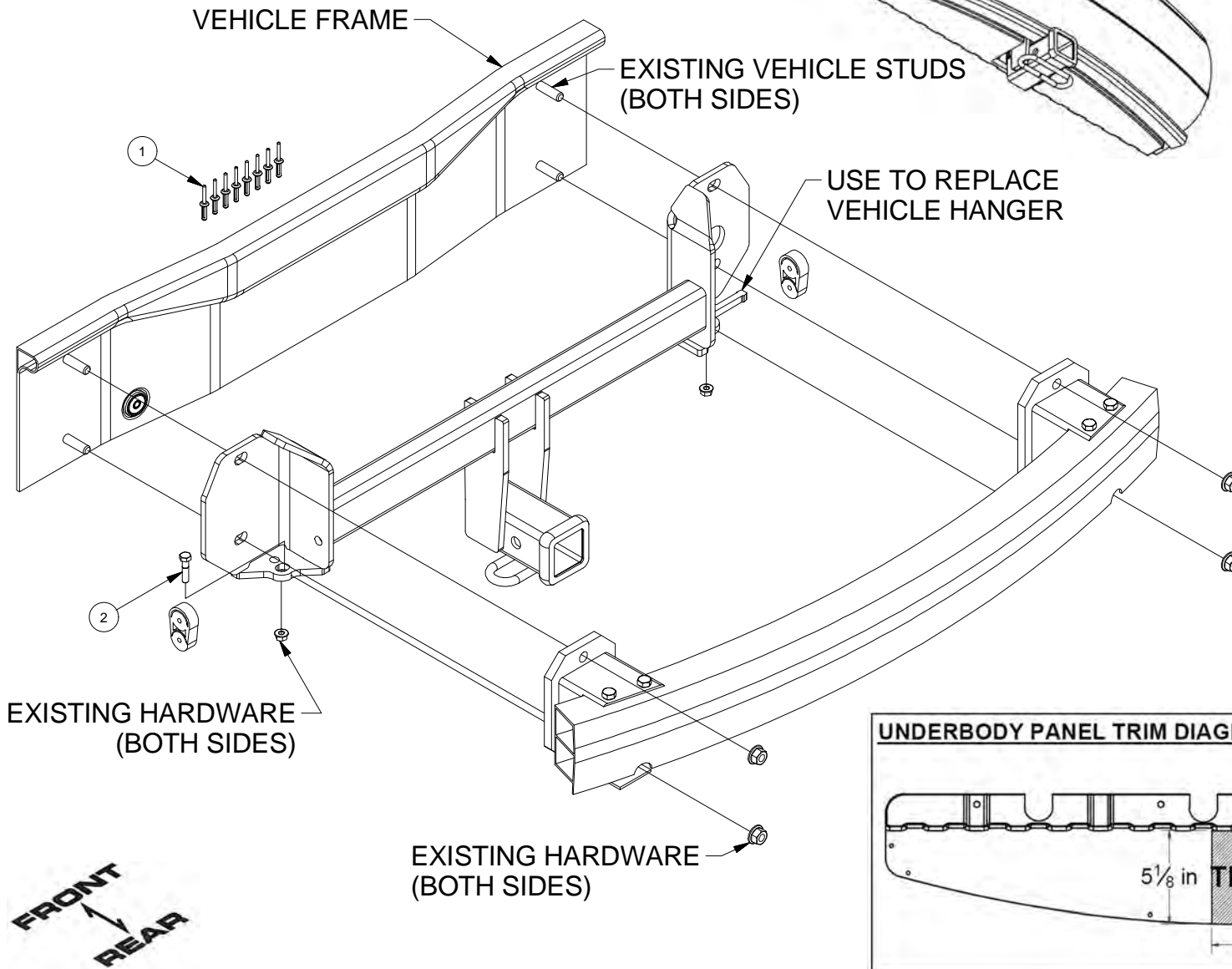

INSTALLED POSITION

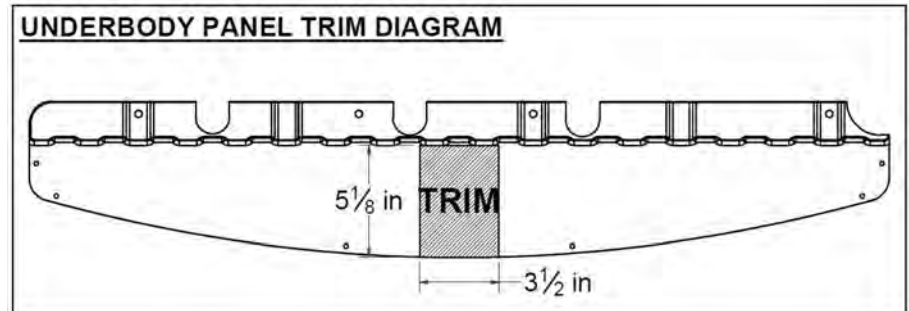
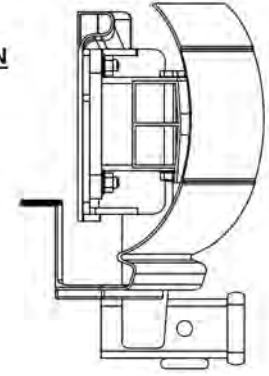

INSTALLATION WALKTHROUGH:

1. Remove underbody panel by removing (10) fasteners using 8mm socket.

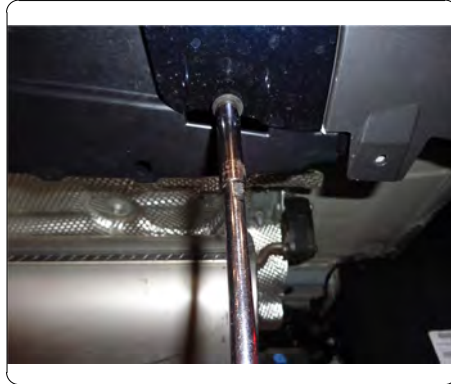

2. Located on bottom of rear fascia remove (3) fasteners on each side using 8mm socket. Inside wheel well trim remove (1) fastener on each side using 8mm socket

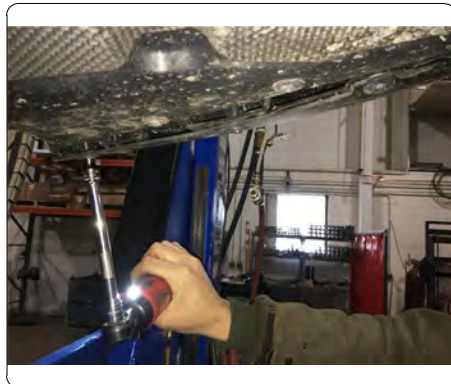
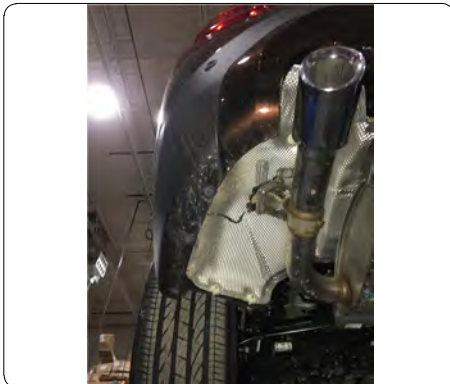

3. Remove (3) rivets from wheel well trim above each tire. To remove rivets push small center rod through rivet with a small punch. Pry rivets from trim.
NOTE: Replacement rivets included.



4. Remove (2) fasteners from each side of bumper cover using 8 mm socket which are now accessible due to wheel well trim removal.

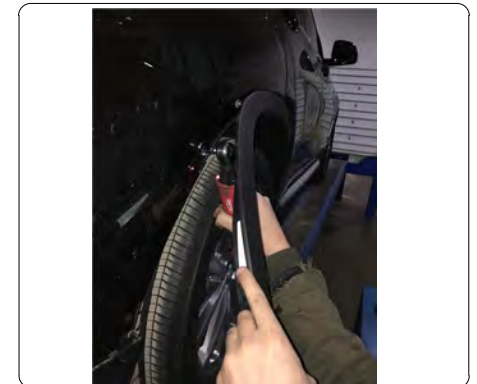

INSTALLATION WALKTHROUGH:

5. Remove (1) plastic clip on each side using a pry tool. Gently unclip plastic covers located on inside of each tail light.



6. Located in trunk of vehicle remove interior panel to access tail light and remove exposed fastener using 10mm socket.



7. Remove (2) nuts from each tail light using 10mm socket.



8. Unplug electrical harness and gently remove each tail light. Remove (1) fastener from rear fascia under each tail light on each side using 8mm socket.

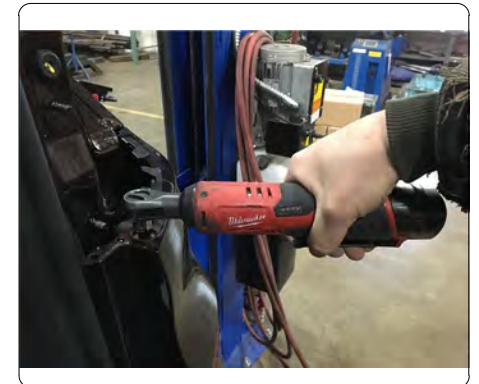

INSTALLATION WALKTHROUGH:

9. Gently unclip (1) reflector on each side of rear fascia to access and remove (1) fastener on each side using 8mm socket.

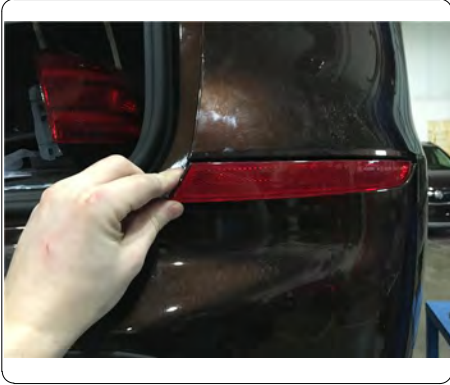

10. Carefully remove rear fascia by releasing press in tabs along top portion of rear fascia. If present, unclip electrical harness.

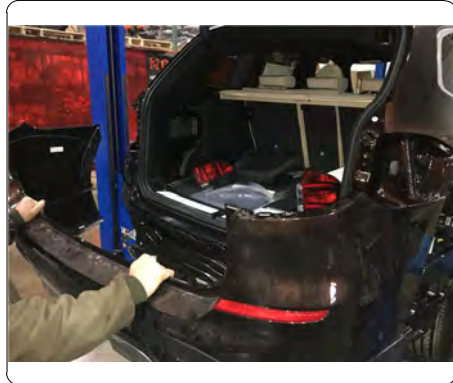
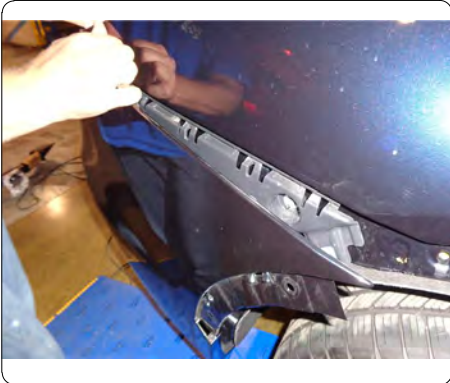

11. Remove bumper beam by removing (2) nuts on each side using 18mm socket. Also remove (1) nut on each side from exhaust hanger that is attached to bumper beam using 13mm socket. Remove passenger side hanger and return to owner. If present, unclip electrical harness.

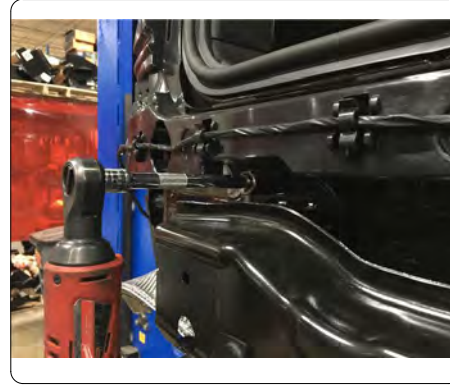

12. Raise hitch and bumper beam into position onto vehicle studs and secure using existing vehicle hardware. Use vehicle hardware to reattach driver side hanger bracket. Use hanger on hitch to reattach passenger side exhaust. **NOTE:** Remove driver side exhaust bracket stud and replace with provided M8 hardware.



INSTALLATION WALKTHROUGH:

13. Torque all M12 hardware to 86 ft-lbs. Torque all M8 hardware to 23 ft-lbs.



14. Reinstall rear fascia and tail lights by reassembling components removed in STEPS 2-10 in reverse order.
NOTE: A plastic rivet gun is required to fasten supplied rivets when reinstalling wheel well trim.

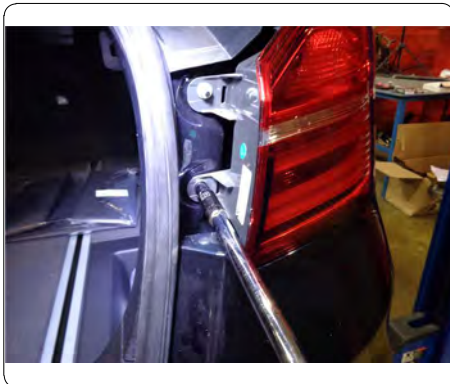

For more information log onto www.curtmfg.com

15. Trim underbody panel. See UNDERBODY TRIM DIAGRAM use as reference. Reinstall underbody panel as removed in STEP 1.

NOTE: All dimensions are approximate, confirm fit prior to trimming.

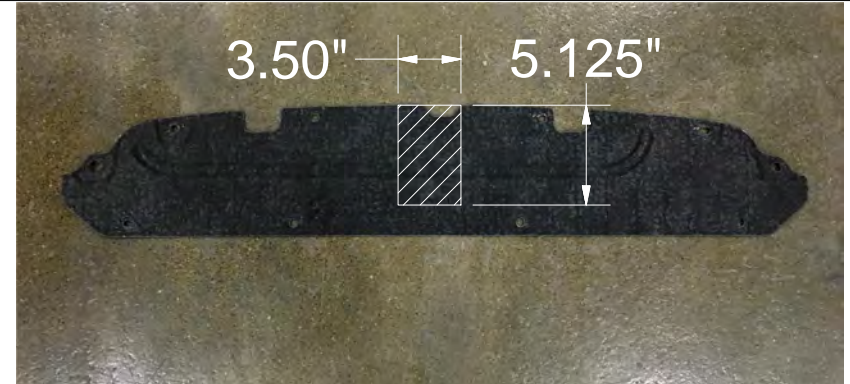

INSTALL COMPLETE



TOWING SAFETY INFORMATION

Gross Trailer Weight / GTW

The Gross Trailer Weight is the weight of the trailer & cargo. Measure this by putting the fully loaded trailer on a vehicle scale.



Tongue Weight / TW

The downward force that is exerted on the hitch ball by the coupler. The tongue weight will vary depending on where the load is positioned in relationship to the trailer axle(s). To measure the tongue weight, use either a commercial scale or a bathroom scale with the coupler at towing height. When using a bathroom scale with heavier tongue weights, use the method shown and multiply the scale reading by 3.

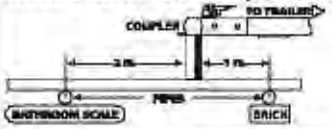

Weight Carrying / WC

The total weight of both the trailer and the cargo inside. Never exceed the weight capacity of your trailer hitch.

Weight Distribution / WD

Used to balance the weight of the cargo between the front and rear wheels throughout the trailer, allowing for better steering, braking, and level riding.



Sway Control

A device used to reduce the lateral movements of the trailer that are caused by the wind. This works in conjunction with a weight distribution hitch. Do not use this on a class 1 or 2 hitch, or with surge brakes.

How Much Can You Safely Tow?

TONGUE WEIGHT ¹ <small>Tongue weight should not exceed 10% percent of the gross trailer weight.</small>	TRAILER CLASS									
	CLASS 1	CLASS 2	CLASS 3	CLASS 4	CLASS 5	CLASS 6	CLASS 7	CLASS 8	CLASS 9	CLASS 10
TRAILER TYPE										
Coupler										
1-1/2"	1100	1200	1300	1400	1500	1600				
Weighted										
1-1/2"	2100	2400	2700	3000	3300	3600	3900	4200	4500	4800
Weighted										
2"	2800	3200	3600	4000	4400	4800	5200	5600	6000	6400
2-1/2" Weighted										
2"										

Refer to owner's manual for towing capabilities and limitations.

Ball Mount

The ball mount is placed inside the opening of the receiver hitch which is mounted to the vehicle. Make sure a hitch pin and clip is properly securing the ball mount to the receiver hitch before you begin towing.

• A: Rise. B: Drop. C: Hole Size. D: Length.

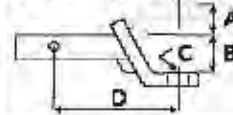

Trailer Ball

The connection from the hitch to the trailer. There are many factors that determine the correct hitch ball:

- Number one is the hitch ball's gross trailer weight rating.
- The mounting platform must be at least 3/8" thick.
- The hole diameter must not be more than 1/16" larger than the threaded shank.
- Every time you tow, check the nut and lock washer to make sure they are fastened securely.



• A: Ball Dia. B: Shank Dia. C: Shank Length. D: Shank Rise.

Coupler

The component that is placed over the trailer ball to connect the vehicle to the trailer. Be sure that the coupler size matches the size of the hitch ball and that the coupler handle is securely fastened. To determine what size hitch ball you need for your application you will need to know the size of coupler that is on the trailer. Be sure your coupler is properly adjusted to the ball you are using.

NOTE: For added security the use of safety devices such as Coupler Safety Pins and Locks is strongly recommended.

Safety Chains

Safety chains are a requirement and should be crossed under the tongue of the trailer so that the tongue will not drop to the road if it becomes separated from the hitch. Always leave enough slack so you can turn. Never allow the safety chains to drag on the ground and never attach the chains to the bumper.

Trailer Classification: Safety Chain Breaking Force - Minimum

Class 1: 2,000 lbs. (8.9 kN)

Class 2: 3,500 lbs. (15.6 kN)

Class 3: 5,000 lbs. (22.2 kN)

The strength rating of each length of safety chain or its equivalent and its attachments shall be equal to or exceed in minimum breaking force the GVWR (Gross Vehicle Weight Rating) of the trailer.

Electrical

Trailer lights, Electric Brakes, Break-away systems - Every time you tow, be sure to check that all components are working properly.

Wiring identification by color:



13387

BMW X3

6/26/2018

PAGE 1 of 2

GROSS LOAD CAPACITY WHEN USED AS A WEIGHT CARRYING HITCH: 5,000 LBS. TRAILER WEIGHT & 750 LBS. TONGUE WEIGHT.

WARNING: ALL NON-TRAILER (WHEEL-LESS) LOADS APPLIED TO THIS PRODUCT MUST BE SUPPORTED BY 18050 STABILIZING STRAPS.

WARNING: ** FAILURE TO PROPERLY SUPPORT NON-TRAILER LOADS WILL VOID PRODUCT WARRANTY **

WARNING: *** DO NOT EXCEED VEHICLE MANUFACTURER'S RECOMMENDED TOWING CAPACITY ***



FOR MORE INFORMATION LOG ONTO WWW.CURTMFG.COM
 HAVING INSTALLATION QUESTIONS? CALL TECHNICAL SUPPORT AT 1-800-798-0813

Parts List			
ITEM	QTY	PART NUMBER	DESCRIPTION
1	8	M6 RIVET	NYLON RIVET (AUVECO #20754)
2	1	M8-1.25 x 35	HEX BOLT



TOOLS REQUIRED
PLASTIC RIVET GUN
8mm / 10mm / 18mm SOCKETS
RATCHET
PRY TOOL
TORQUE WRENCH
TAPE MEASURE
ROTARY CUTTING TOOL
SMALL PUNCH
SAFETY GLASSES

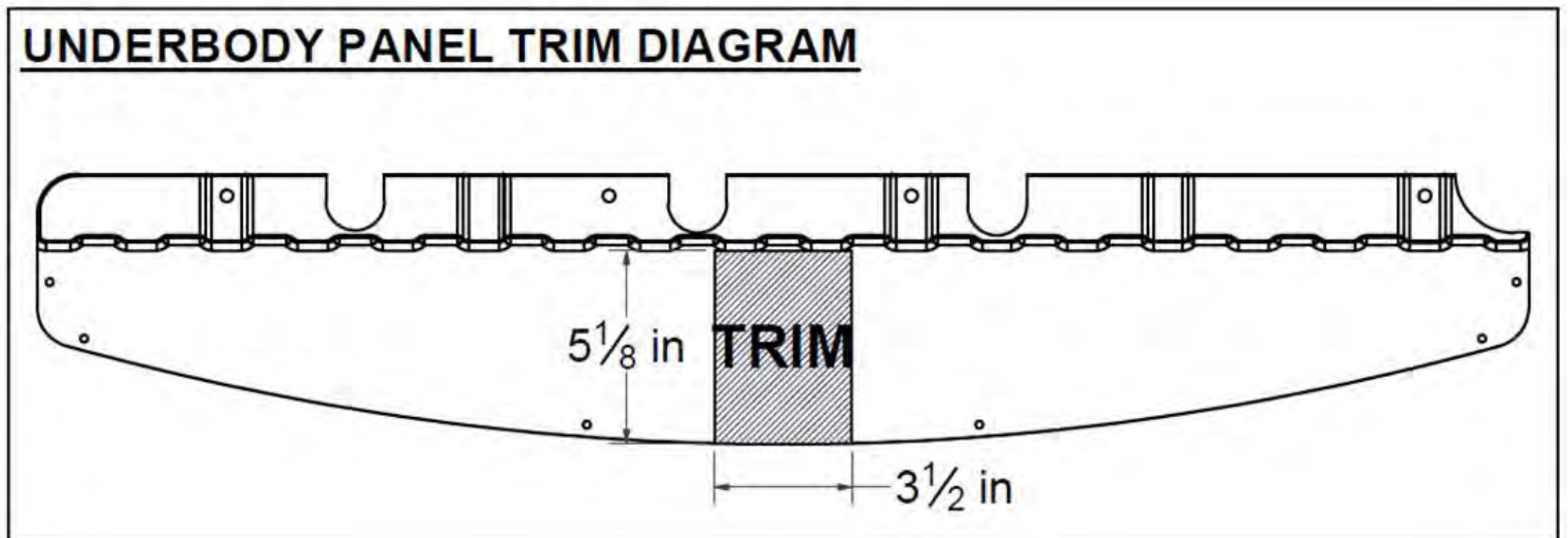
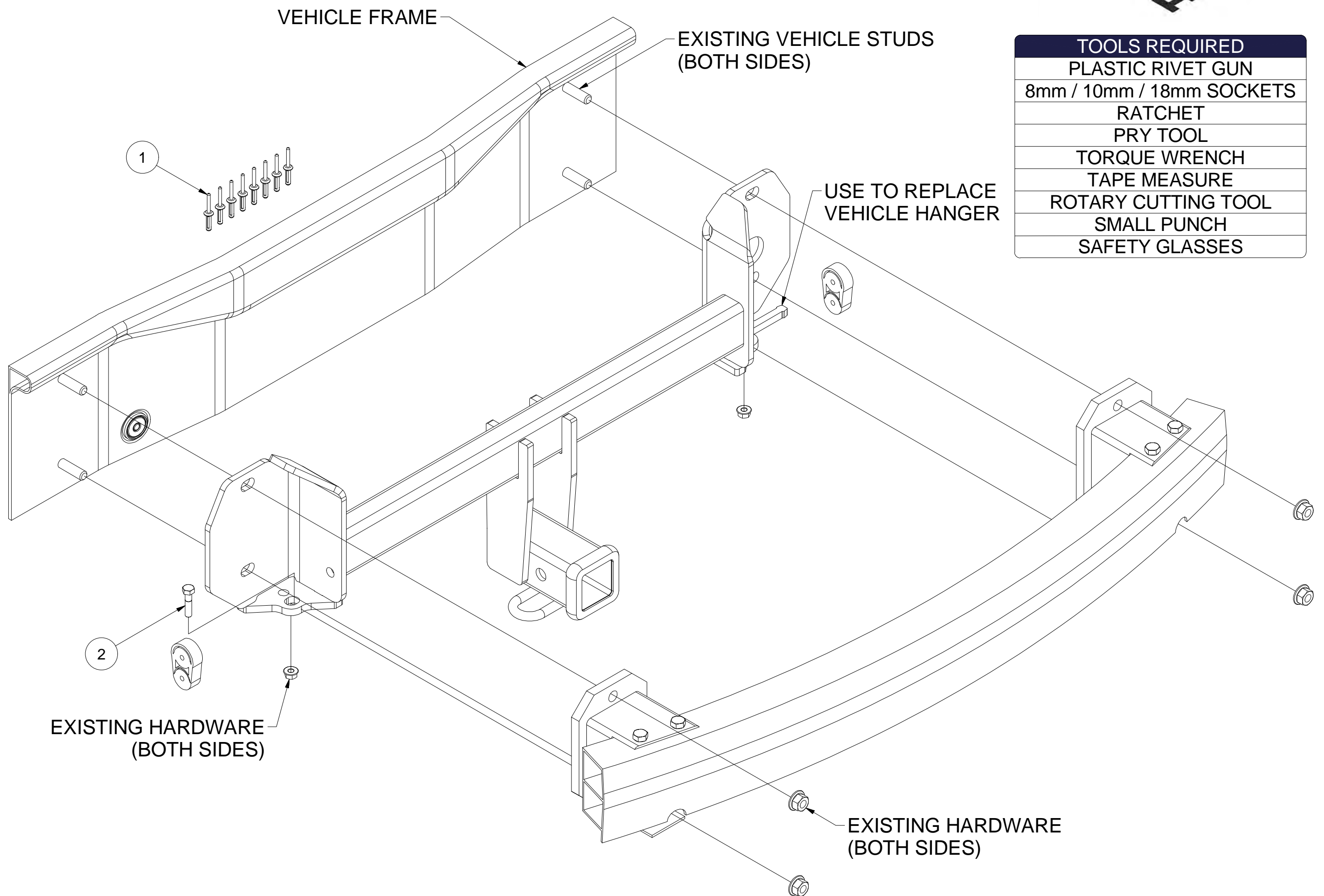

HITCH WEIGHT: 25 LBS.

INSTALL TIME

PROFESSIONAL: 90 MINUTES

NOVICE (DIY): 180 MINUTES

INSTALL NOTES:

- REMOVE BUMPER
- TRIM UNDERBODY PANEL
- NO DRILLING

PERIODICALLY CHECK THIS RECEIVER HITCH TO ENSURE THAT ALL FASTENERS ARE TIGHT AND THAT ALL STRUCTURAL COMPONENTS ARE SOUND.

CURT Manufacturing LLC., warrants this product to be free of defects in material and/or workmanship at the time of retail purchase by the original purchaser. If the product is found to be defective, CURT Manufacturing LLC., may repair or replace the product, at their option, when the product is returned, prepaid, with proof of purchase. Alteration to, misuse of, or improper installation of this product voids the warranty. CURT Manufacturing LLC.'s liability is limited to repair or replacement of products found to be defective, and specifically excludes liability for incidental or consequential loss or damage.

This product complies with safety specifications and requirements for connecting devices and towing systems of the state of New York, V.E.S.C.Regulation V-5 and SAE J684.



Scan for more information

HAVING INSTALLATION QUESTIONS? CALL TECHNICAL SUPPORT AT 1-800-798-0813

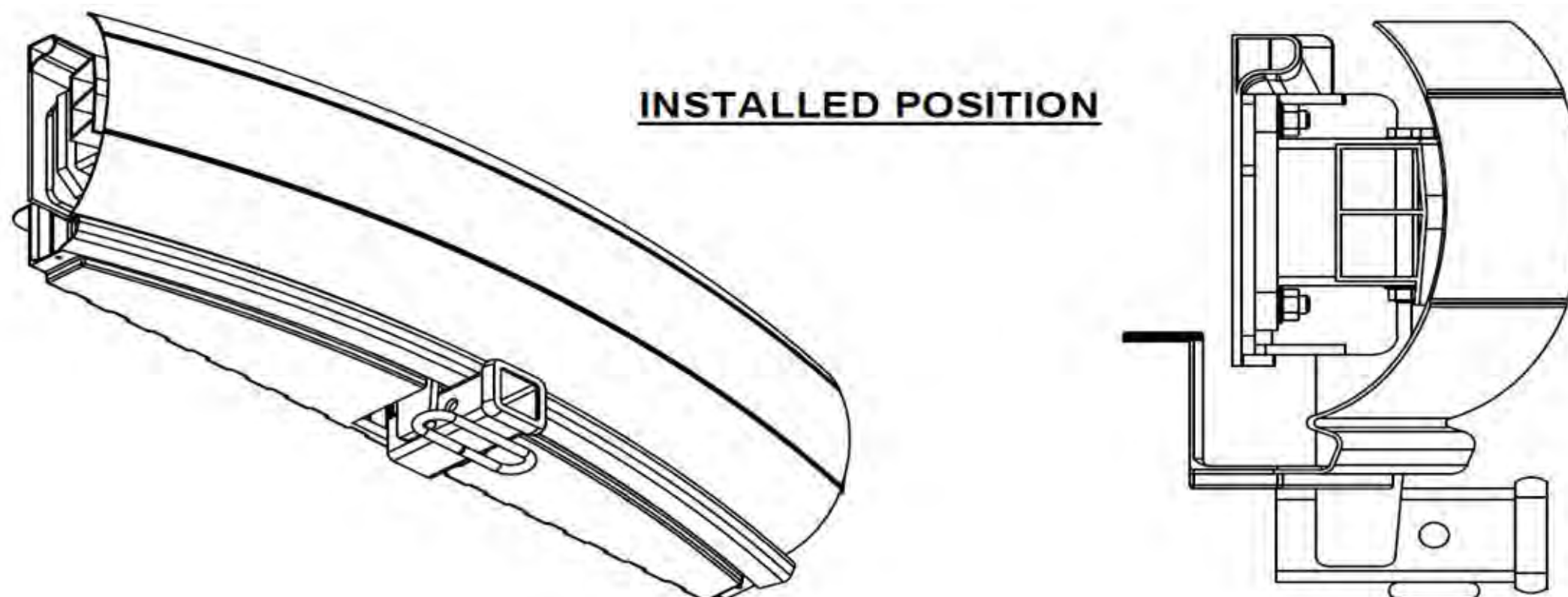

INSTALLATION STEPS

1. Remove underbody panel by removing (10) fasteners using 8mm socket.
2. Located on bottom of rear fascia remove (3) fasteners on each side using 8mm socket. Inside wheel well trim remove (1) fastener on each side using 8mm socket.
3. Remove (3) rivets from wheel well trim from above each rear tire. To remove rivets push small center rod through rivet with a small punch. Pry rivets from trim.
NOTE: Replacement rivets are included.
4. Remove (2) fasteners from each side of bumper cover using 8mm socket which are now accessible due to wheel well trim removal.
5. Remove (1) plastic clip on each side using a pry tool. Gently unclip plastic covers located on inside of each tail light.
6. Located in trunk of vehicle remove interior panel to access tail light and remove exposed fastener using 10mm socket.
7. Remove (2) nuts from each tail light using 10mm socket. Unplug electrical harness and gently remove each tail light.
8. Remove (1) fastener from rear fascia under each tail light.
9. Gently unclip (1) reflector on each side of rear fascia to access and remove (1) fastener on each side using 8mm socket.
10. Carefully remove rear fascia by releasing press in tabs along top portion of rear fascia. If present, unclip electrical harness.
11. Remove bumper beam by removing (2) nuts on each side using 18mm socket. Also remove (1) nut using on each side from exhaust hanger that is attached to bumper beam using 13mm socket. Remove passenger side hanger from isolator and return to owner. If present, unclip electrical harness.
12. Raise hitch and bumper beam into position onto vehicle studs and secure to vehicle using existing vehicle hardware. Use vehicle hardware to reattach driver side exhaust hanger. Use vehicle hardware to reattach driver side exhaust hanger bracket. Use hanger on hitch to reattach passenger side exhaust.
NOTE: Located on rear bumper remove driver side exhaust bracket stud and replace with provided M8 hardware.
13. Torque all M12 hardware to 86 ft-lbs. Torque all M8 hardware to 23 ft-lbs.
14. Reinstall rear fascia and tail lights by reassembling components removed in STEPS 2-10 in reverse order.
NOTE: A plastic rivet gun is required to fasten supplied rivets when reinstalling wheel well trim.
15. Trim underbody panel. See UNDERBODY PANEL TRIM DIAGRAM use as a reference. Reinstall underbody panel as removed in STEP 1.
NOTE: All dimensions are approximate, confirm fit prior to trimming.

PERIODICALLY CHECK THIS RECEIVER HITCH TO ENSURE THAT ALL FASTENERS ARE TIGHT AND THAT ALL STRUCTURAL COMPONENTS ARE SOUND.

CURT Manufacturing LLC., warrants this product to be free of defects in material and/or workmanship at the time of retail purchase by the original purchaser. If the product is found to be defective, CURT Manufacturing LLC., may repair or replace the product, at their option, when the product is returned, prepaid, with proof of purchase. Alteration to, misuse of, or improper installation of this product voids the warranty. CURT Manufacturing LLC.'s liability is limited to repair or replacement of products found to be defective, and specifically excludes liability for incidental or consequential loss or damage.

This product complies with safety specifications and requirements for connecting devices and towing systems of the state of New York, V.E.S.C.Regulation V-5 and SAE J684.