



## Installation Instructions: MT6

# TOYOTA TACOMA 6'2" BED LENGTH

2005-CURRENT

## TOOLS REQUIRED

- Adjustable wrench (that opens to about 1")
- 1/2" open end wrench
- #2 Phillips screwdriver,
- Short 7/32" hex wrench
- 7/16" deep socket
- 3/8" socket
- Electric drill
- 1/8" drill bit
- 9/64" drill bit
- 5/16" drill bit
- Drill stop
- T30 Torx Driver

Watch installation videos at [www.DECKED.com/video](http://www.DECKED.com/video) | Register your system at [www.DECKED.com/warranty](http://www.DECKED.com/warranty)

FOLLOW US:



@DECKEDUSA | #DECKEDUSA

VERSION 1

DECKED.COM | SERVICE@DECKED.COM | 208.806.0251

## ▼ HEY! TORQUE BOY: READ BEFORE YOU INSTALL DECKED ▼

1. **DON'T** over tighten bolts, get em' good 'ole hand-tight.
2. **DON'T** use power tools.
3. If you don't follow directions and do use power tools:
  - 1). Set clutch at a very low setting.
  - 2). Don't blow it.
  - 3). If you blow it, see NOTE.\*

**NOTE\*** Two extra threaded inserts are included in BAG PREP-EXTRA. That's all you get.

- 4). **DON'T** over tighten J-hooks during installation. Make 'em good and snug enough to keep the system from moving in the bed.
- 5). Do read these instructions closely.

**NOTE:** In your BAG PREP-MT6, you will have two types of 1" length bolts and flanged nuts. One bolt has a 1/4" diameter, and the other bolt has a 5/16" diameter. Don't screw this up! The flanged nuts only fit one type of bolt, so you better at least get that right...

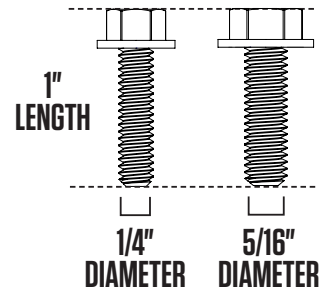

## ▼ ASSEMBLY OVERVIEW ▼

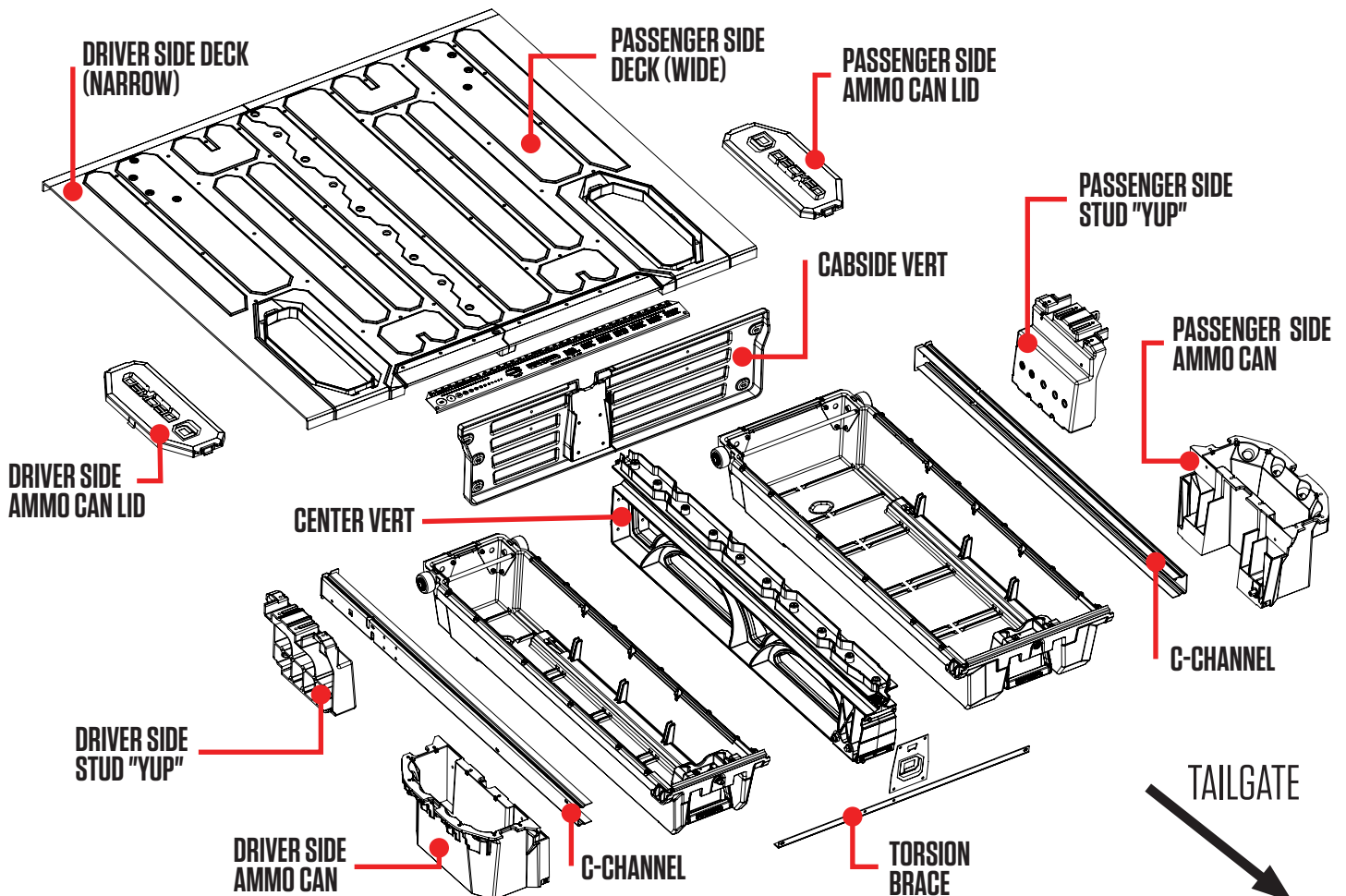

*Need Help? Watch our installation videos or give us a call. We're happy to help!*

**SERVICE@DECKED.COM | 208.806.0251 | DECKED.COM/VIDEO**

# PREP BED: MARK CENTER OF BED

- Use a marking pen or wax pencil to mark a centerline (blue) on the raised center bead.

## DETAIL A

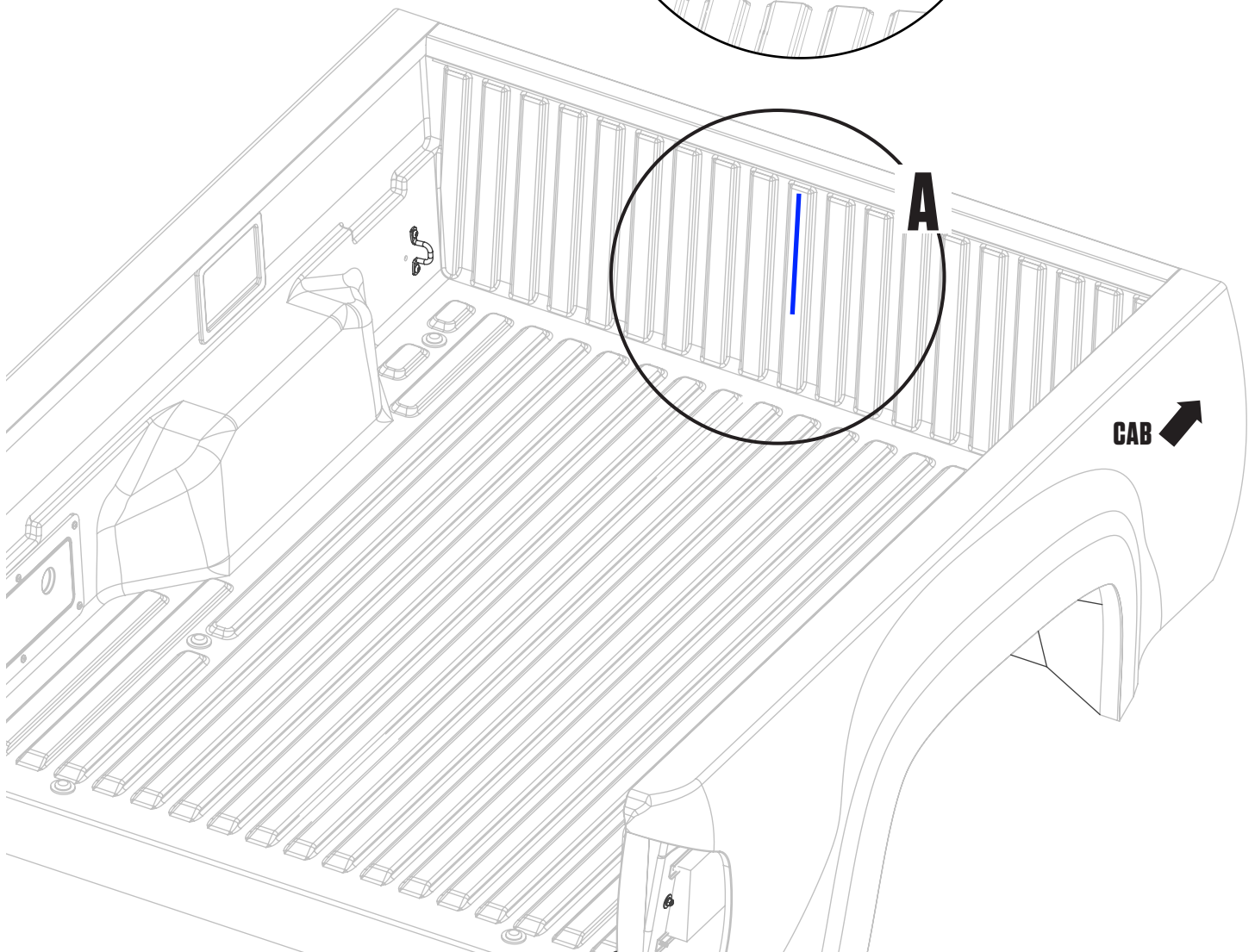
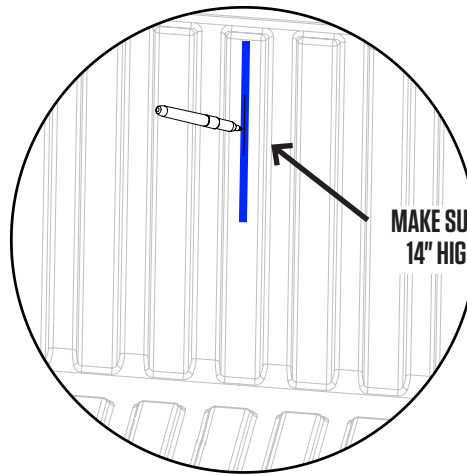

# PREP BED: SHIMS

- **2 SHIMS** that look like this can be found in your hardware kit.
- Using the information below:
  - 1) Clean the bed surface where the shims will be located. Isopropyl alcohol (do not drink) is recommended.
  - 2) Remove tape film and apply shim with the strength of 1000 men a.k.a push really hard.

## DETAIL B

Align shim to channel in floor shown. Place shim 8" from rear of bed (edge in red).

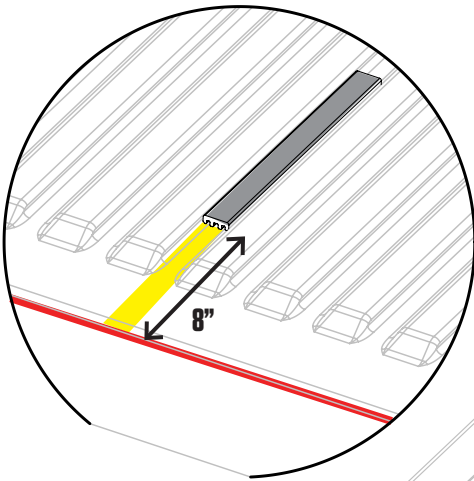

## DETAIL A

Align shim to channel in floor shown 3" from cabside panel of bed (edge in red).

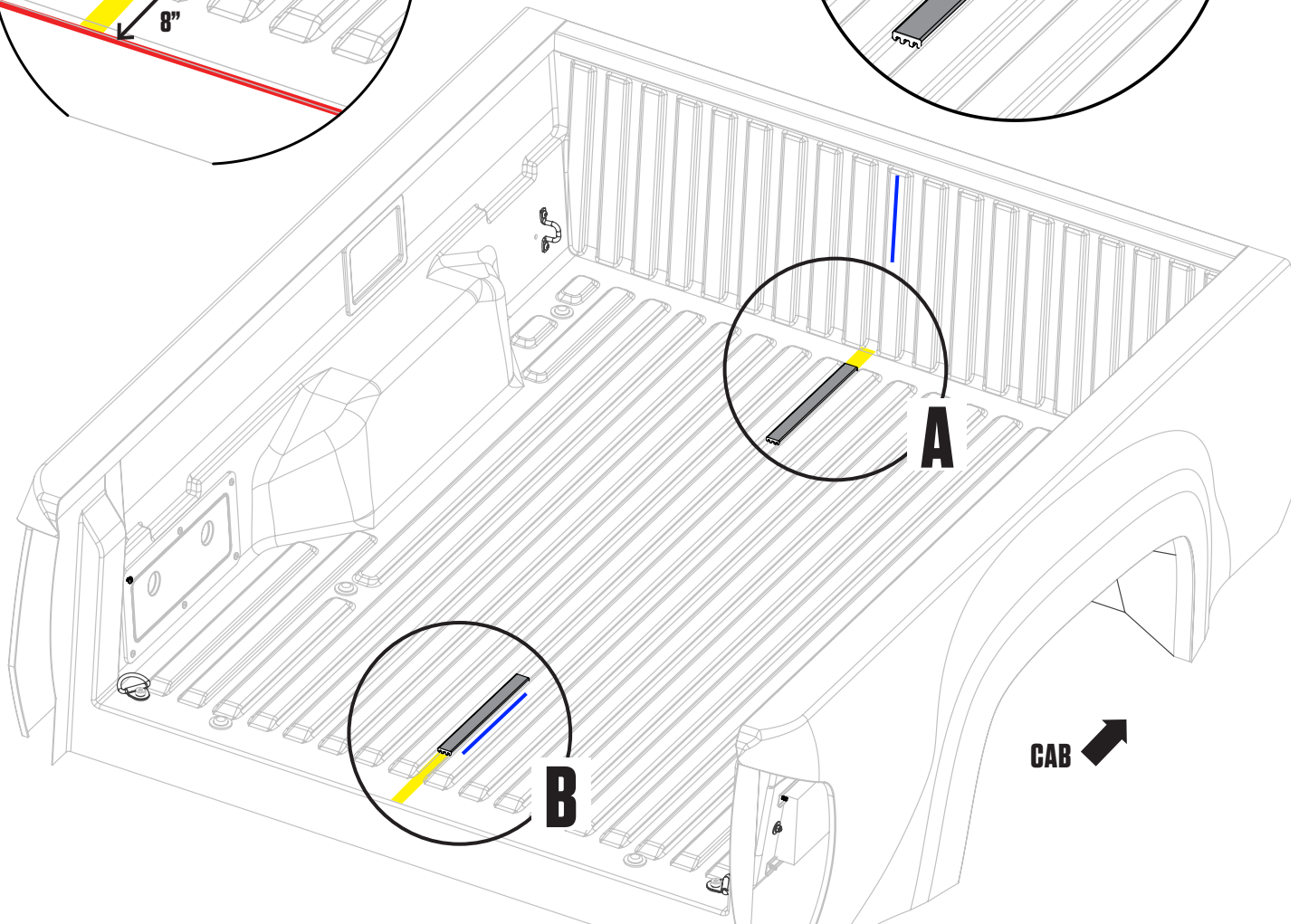
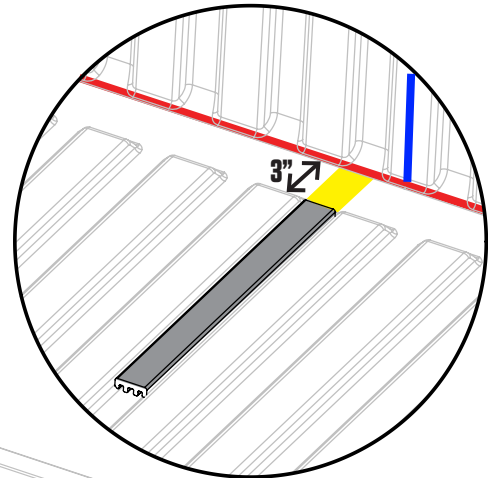



**Do you have a 2005-2014 Tacoma?  
Buy a new one, or **GO TO PAGE 4****

**Do you have a 2015-current Tacoma?  
Stop letting us know, and **GO TO PAGE 5****

# STOP:

Double check that you have a 2005 - 2014 Tacoma without a cabside factory tie-down. If you have a newer model with a cabside factory tie-down (you're stoked!), go directly to page 5.

## PREP BED: CABSIDE BRACKET (2005-2014)

- Follow STEP 1 - STEP 4; BAG PREP-MT6.
- Repeat passenger side.

### STEP 1

Mark bottom hole location (blue) at 2 1/2" up from floor and 4" from cabside panel of bed. Mark top hole location (red) 2 3/4" up from bottom hole and 4" from cabside panel.

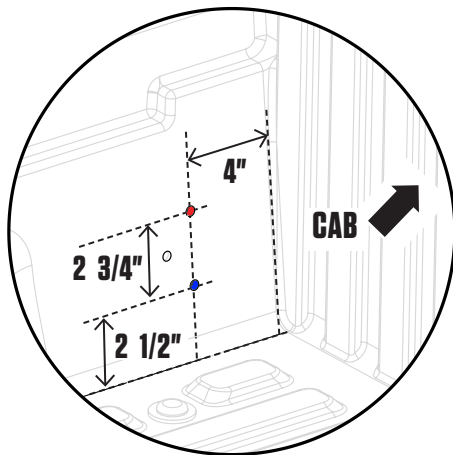

### STEP 2

Mark center hole (green) 1 3/8" up from lower hole center. Mark 1 1/8" toward tailgate from top hole center.

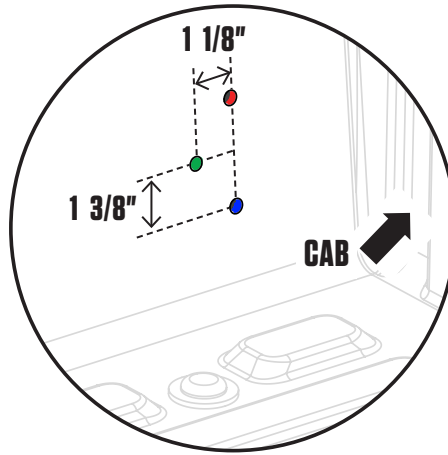

### STEP 3

At all three mark locations, drill a 5/16" hole using a 1/2" drill stop.



### STEP 4

Play Rock Paper Scissors with your pal. The loser needs to hold the backing plate inside the wheel well. Grab three 1" length x 5/16" diameter bolts and place two through the oval cabside bracket holes and one through the round tailgate side hole bracket. Install through backing plate holes shown (green). Securely tighten with flanged nuts.

**BACKER PLATE GOES OUTSIDE THE INNER PLASTIC BED ON THE INTERIOR WHEEL WELL WALL... TRY SAYING THAT THREE TIMES FAST.**

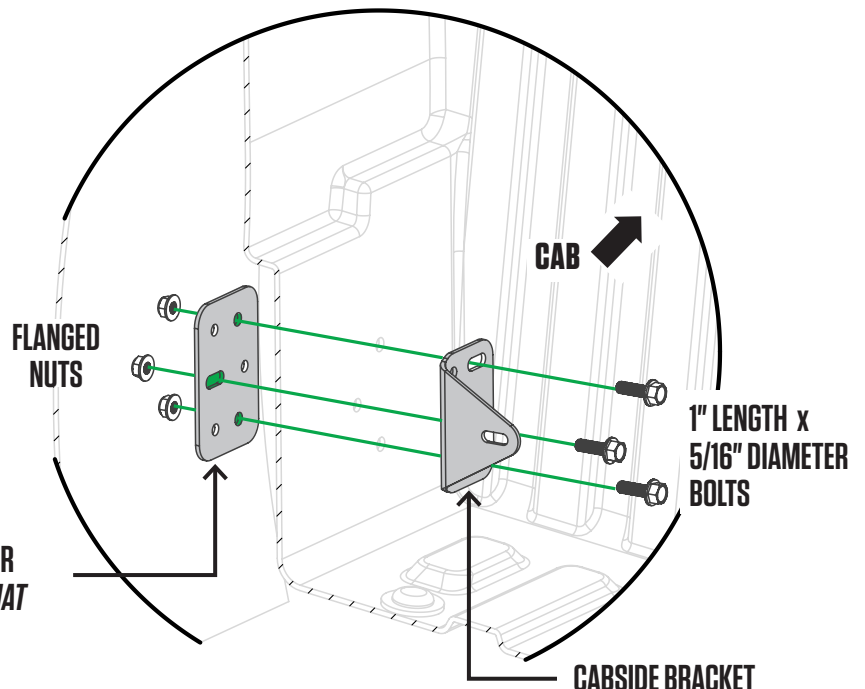

**NOTE: Do not attempt alone. Rock Paper Scissors for who lays on the ground to hold the backing plate.**

# STOP:

Double check that you have a 2015 - current Tacoma with a cabside factory tie-down. If you have an earlier model Tacoma with no cabside factory tie-down, revert to page 4.

## PREP BED: CABSIDE BRACKET (2015-CURRENT)

- Follow STEP 1 - STEP 2; BAG PREP-MT6.
- Repeat passenger side.

**STEP 1** Remove factory cabside tie-down with a T30 torx driver. Keep bolts. Mark 1 3/8" up from lower factory hole center. Mark 1 1/8" toward tailgate from factory hole centers. At center mark (green), drill a 5/16" hole using a 1/2" drill stop.

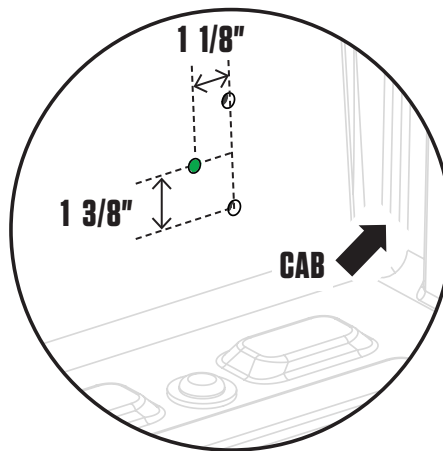
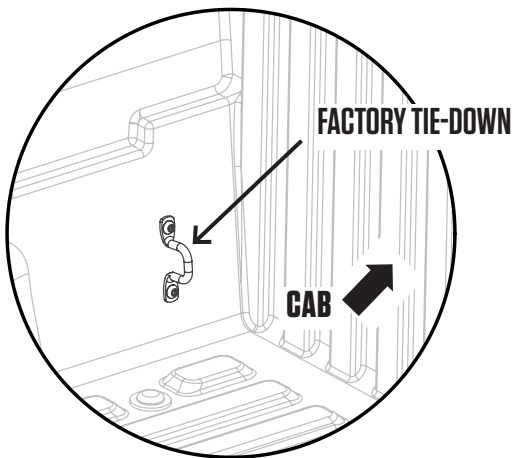

**STEP 2** Install cabside bracket with the two factory tie-down bolts inserted in the oval holes. Play Rock Paper Scissors with your pal. The loser needs to hold the backing plate inside the wheel well. Install one 1" length x 5/16" diameter bolt through center cabside bracket hole into backing plate and install with flanged nut. **NOTE: You'll have four extra 1" bolts and four nuts that you won't need in your MT6 bag. Do with them as you wish.**

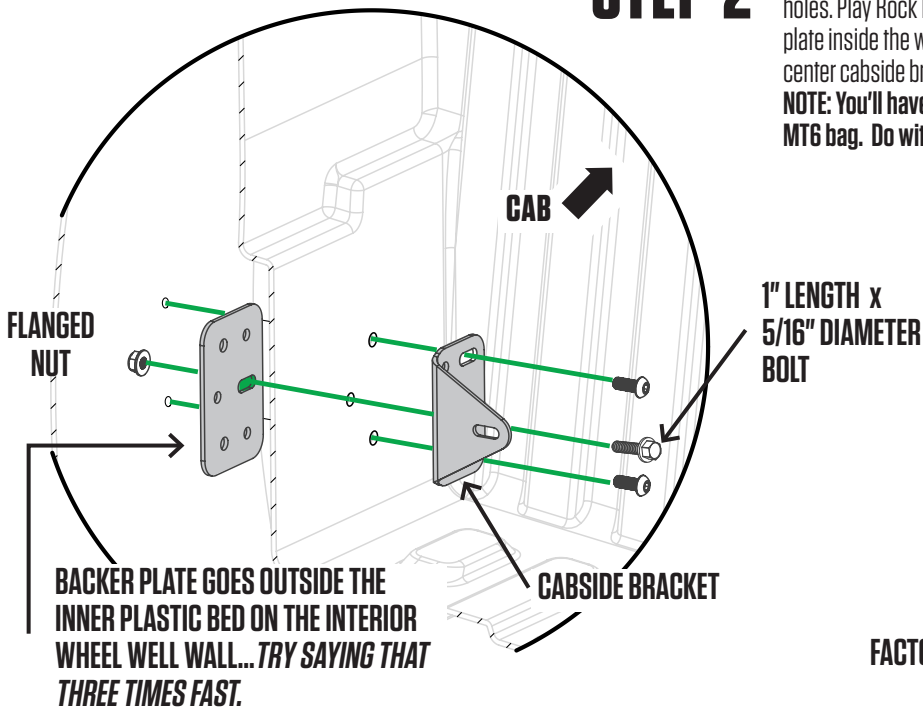

### VIEW FROM WHEEL WELL

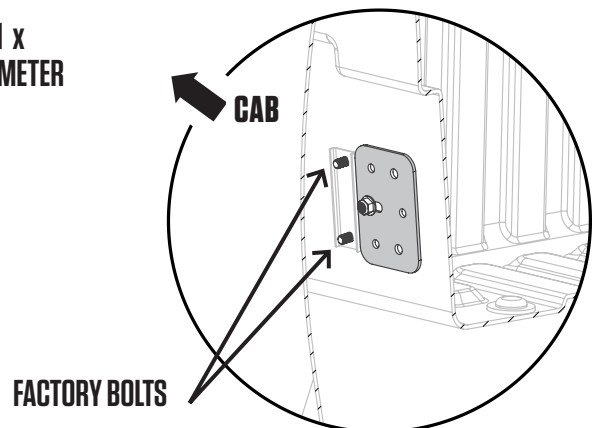

**NOTE: Do not attempt alone. Rock Paper Scissors for who lays on the ground to hold the backing plate.**

# PREP BED: TAILGATE BRACKET

**NOTE: If your pal left, clank some cans together to get them to come back.**

- Remove top rear factory compartment bolt from the driver side with a T30 Torx Driver. Keep bolt.
- Loosely attach driver side tailgate bracket with factory bolt in top hole. Make sure the tie down opening is angled toward the driver, not the tailgate; BAG PREP-MT6.
- Align bracket so it's parallel with vertical edge of compartment. Tighten factory bolt at last!
- Using the bottom hole in bracket as a guide, drill a 5/16" hole with a 1/2" drill stop through compartment and bed wall.
- Install a 1" length x 1/4" diameter bolt and flanged nut in bracket and tighten securely; BAG PREP-MT6.
- Repeat passenger side.

**NOTE: On passenger side ONLY, you will need to add a washer; BAG PREP-MT6...We know it's strange, trust us.**

## DRIVER SIDE

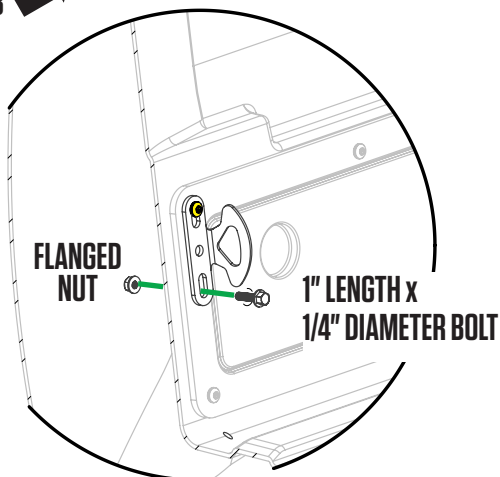
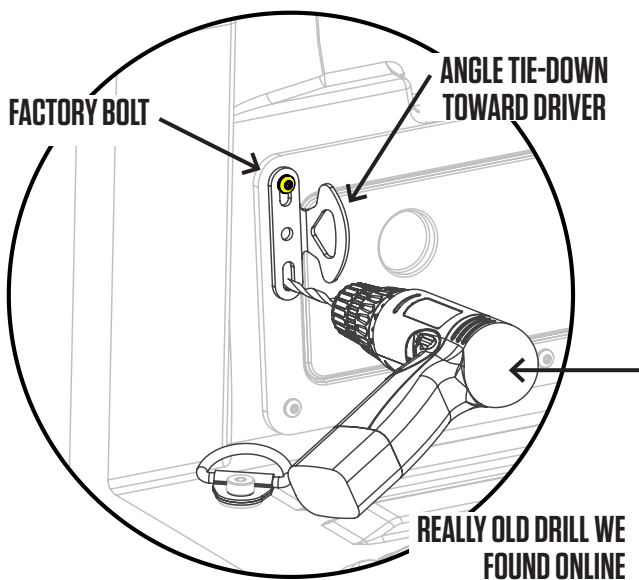

## PASSENGER SIDE

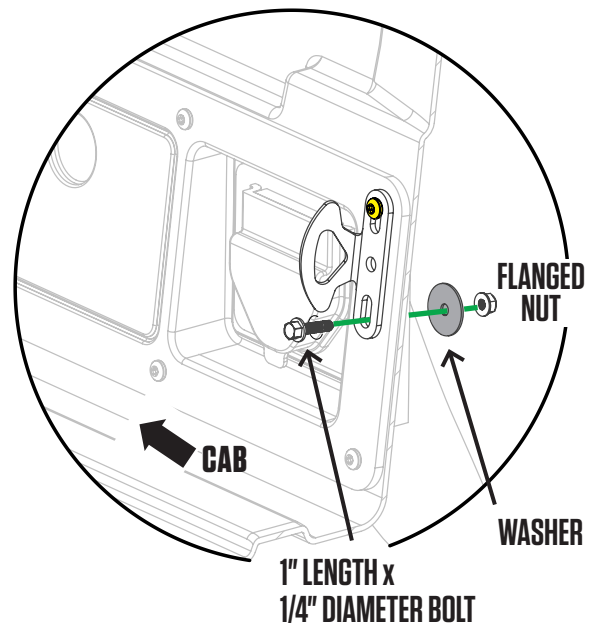

**HELPFUL TIP:** Feel free to remove doors of cubbies so you can still somewhat use them. Use will be compromised, but hey, life ain't always fair, right?!

**HELPFUL TIP:** The power outlet can still be used if you insert a flat head pigtail extension cord BEFORE you install the decks. Make sure to have the outlet capped to keep water out.



# ASSEMBLY: CENTER VERT + CABSIDE VERT

**NOTE:** Perform the next few steps on a flat surface like a garage floor.

- Attach center vert to cabside vert with four bolts. Alternate to tighten; BAG S1.

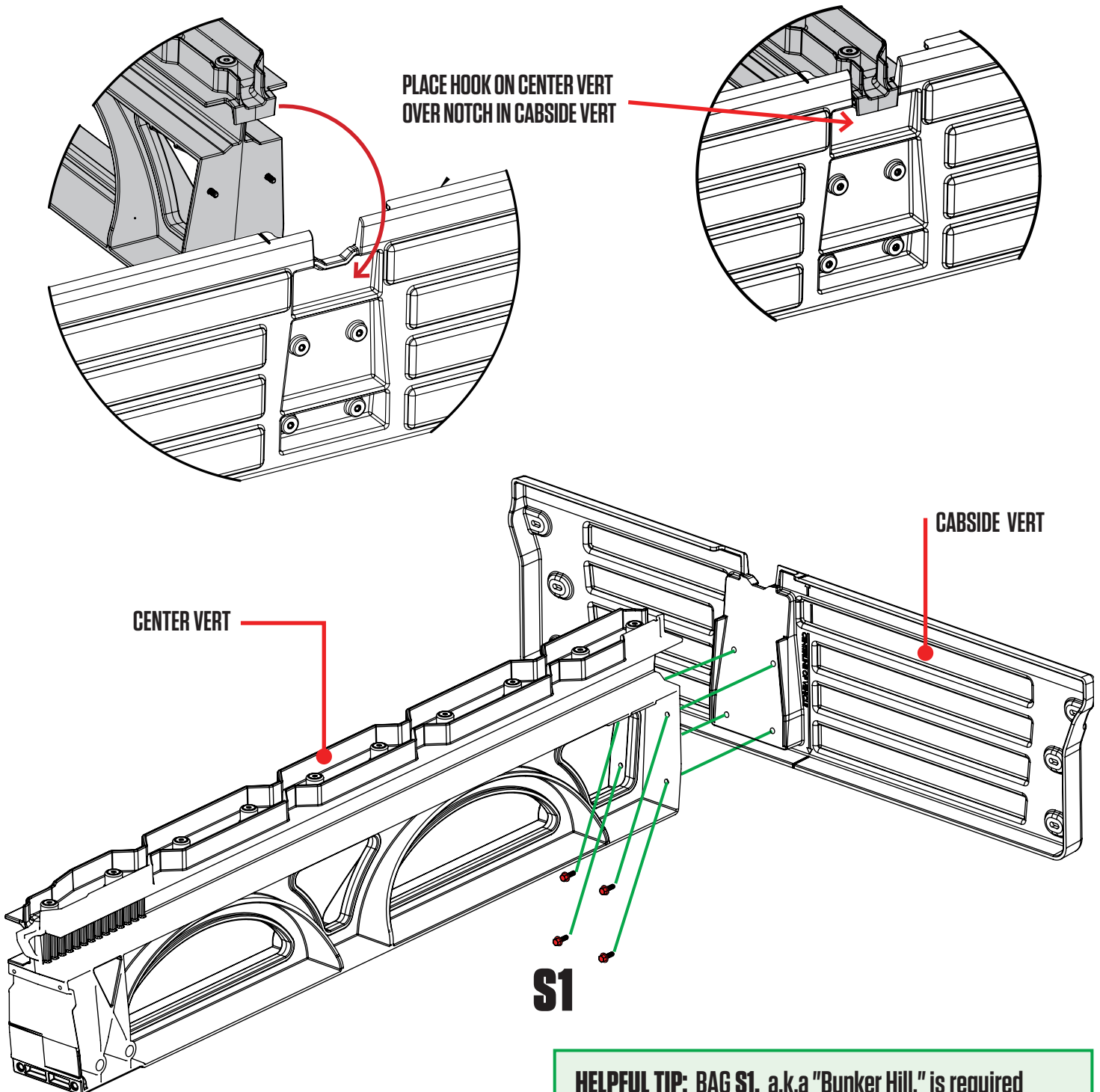

**HELPFUL TIP:** BAG S1, a.k.a "Bunker Hill," is required for most of the steps, so keep it close! These bolts are highlighted throughout instructions in **RED**.

# ASSEMBLY: LOOSELY ATTACH STUDS (YUP)

- **LOOSELY** attach studs to cabside vert with six bolts; BAG **S1**.

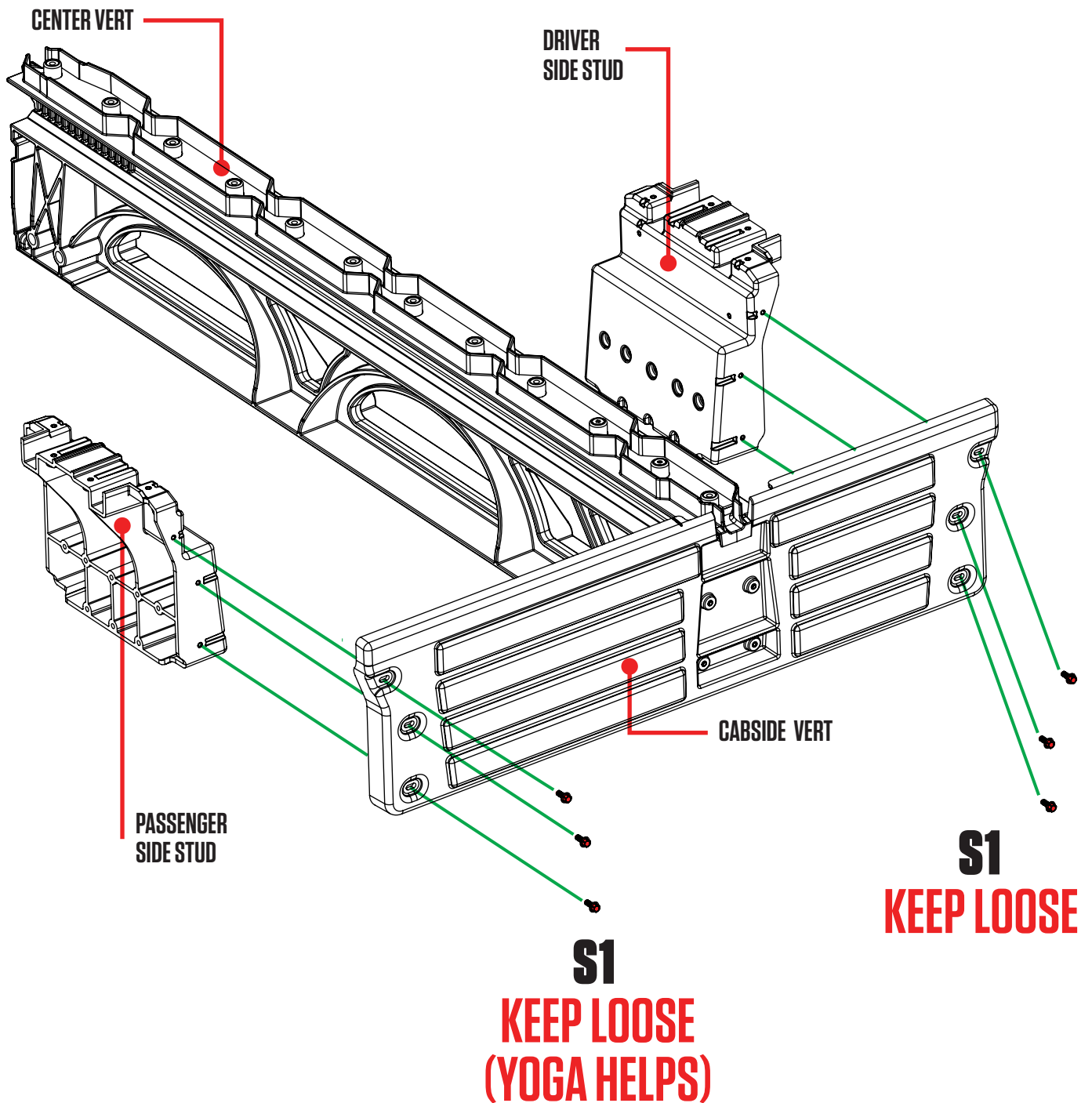

# ASSEMBLY: ALIGN & TIGHTEN STUDS (YUP)

**NOTE:** This step ensures the studs are properly located before tightening bolts. It's important.

- Place ammo cans to support tailgate end of deck panels.
- Lift deck panels on center vert + stud + cabside vert assembly.
- Slide studs around L-R until deck panels are seated.
- **DETAIL A:** Loosely secure four bolts to hold decks onto studs; **BAG S1**.
- Now you can securely tighten the bolts that hold the studs to the cabside vert.
- Unbolt deck from studs, remove deck panels, save bolts, remove ammo cans and set aside for later assembly.

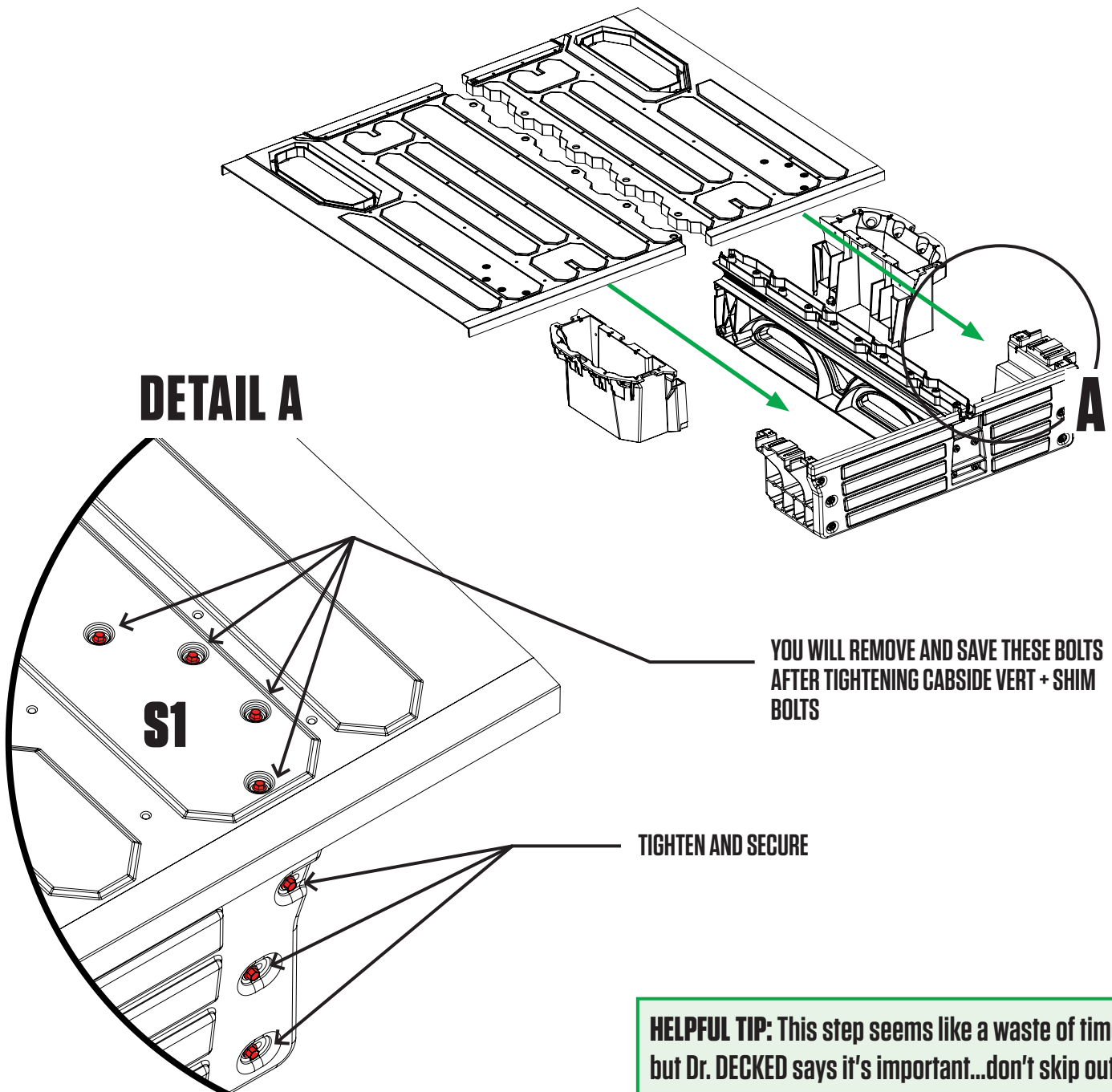

# ASSEMBLY: STUD BRACKETS

- **DETAIL A:** Securely attach stud bracket to driver side stud using three 3 1/2" length bolts and flanged nut in holes shown; BAG PREP-MT6.
- **DETAIL B:** Securely attach stud bracket to passenger side stud using three 3 1/2" length bolts and flanged nut; BAG PREP-MT6.

## DETAIL A

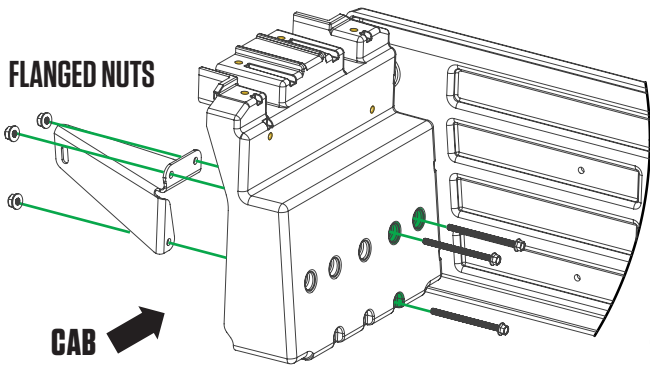

## DETAIL B

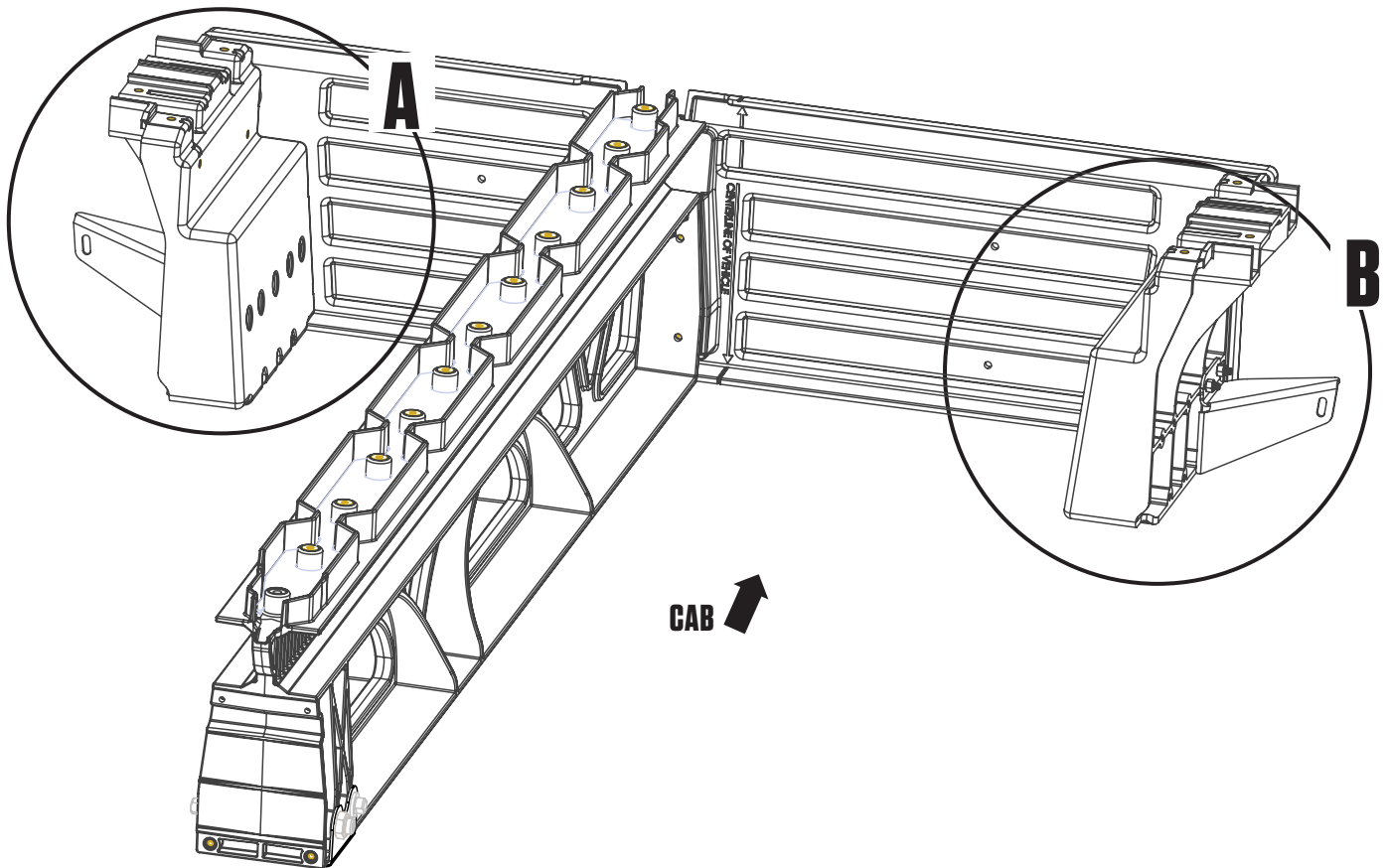
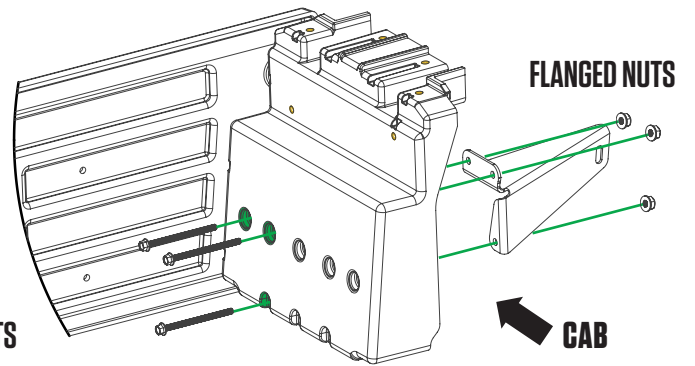

# INSTALL: MOUNTING + CABSIDE ATTACHMENT

- While supporting both ends, lift center vert + stud + cabside vert assembly in truck bed. Position against cabside panel of bed with stud bracket **cabside** of cabside bracket.
- **DETAIL A:** Install a 3/4" length bolt and flanged nut and tighten securely; BAG PREP-MT6.
- Repeat passenger side.

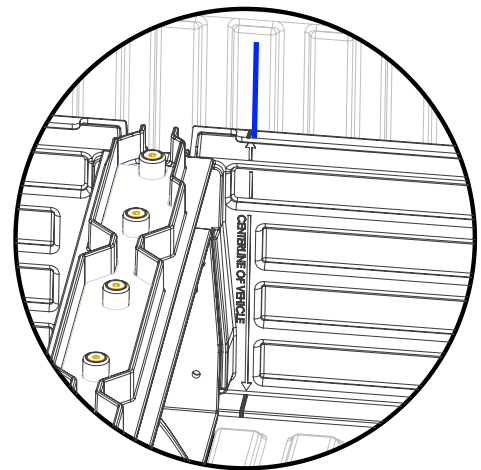
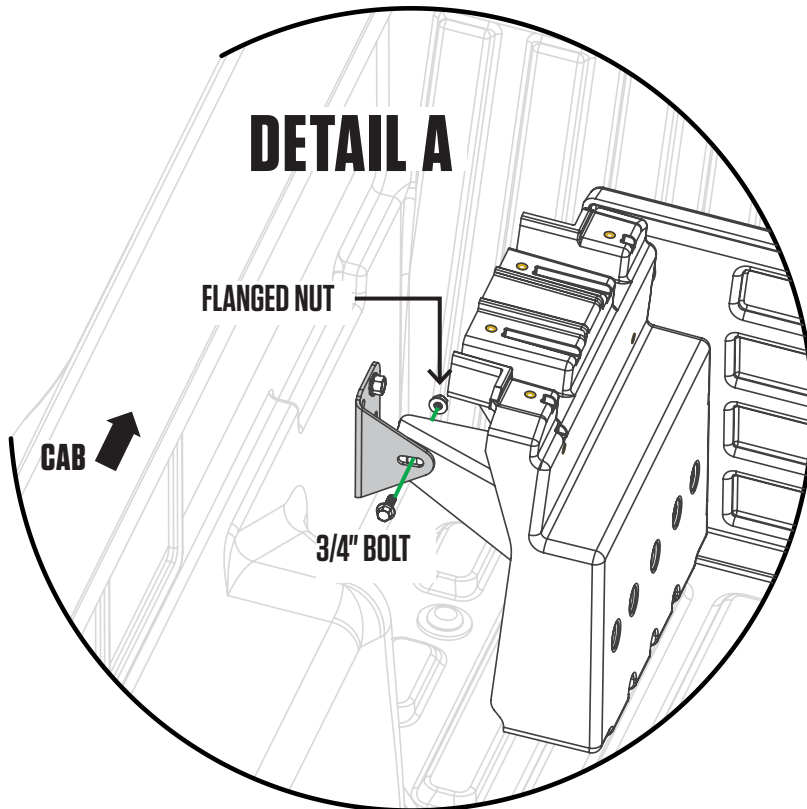

**NOTE:** Make sure centerline arrows on cabside vert are aligned with your centerline mark (blue).

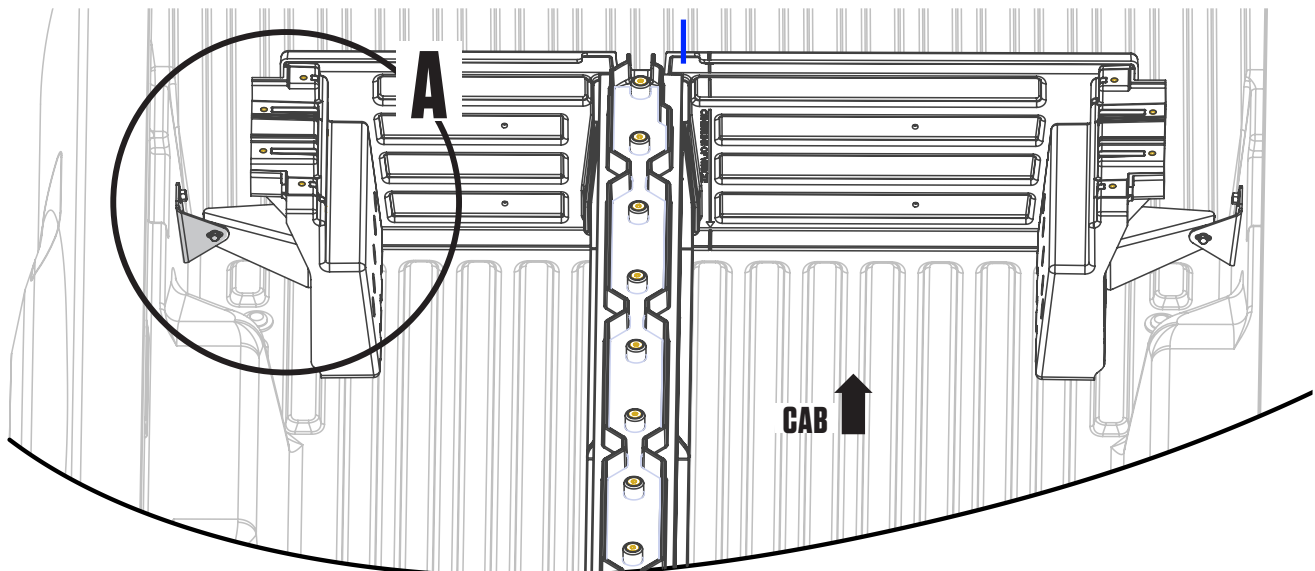

# INSTALL: C-CHANNEL

- Loosely place driver side ammo can at tailgate corner of bed.
- Place driver side C-channel on ledge of stud and ammo can with end plate cabside.
- **DETAIL A:** Insert two bolts through C-channel into ammo can and loosely fasten with nut; BAG **S2**, BAG **N1**.
- **DETAIL B:** Tightly attach C-channel to stud; BAG **S1**.
- Repeat passenger side.

## DETAIL A KEEP LOOSE

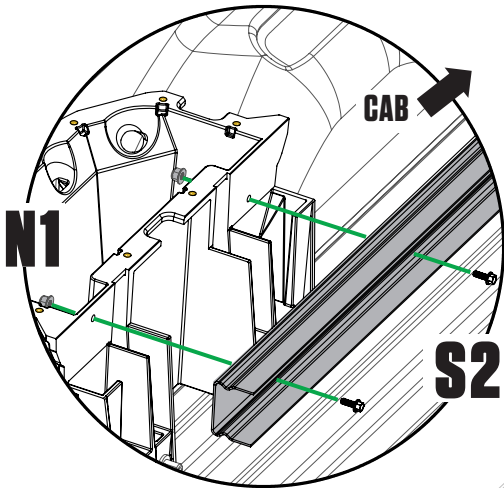

## DETAIL B TIGHTEN

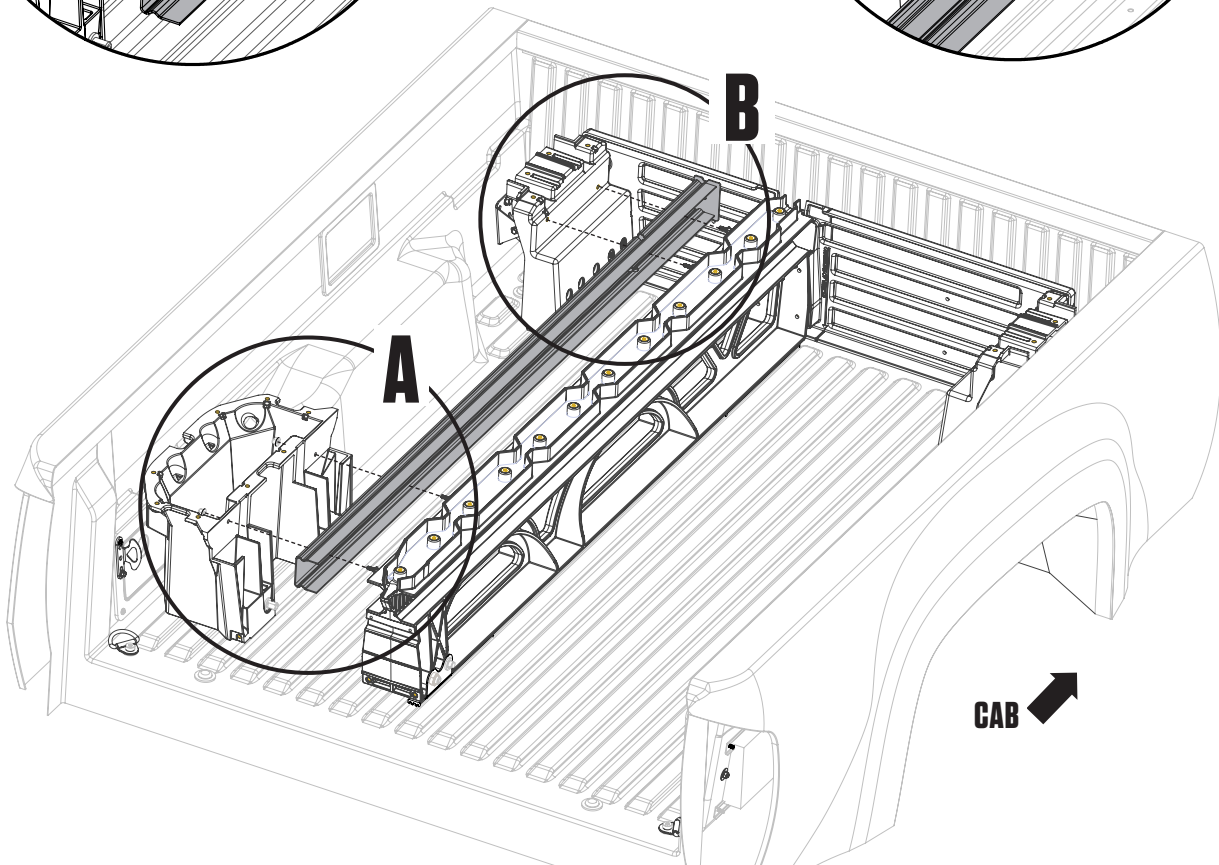
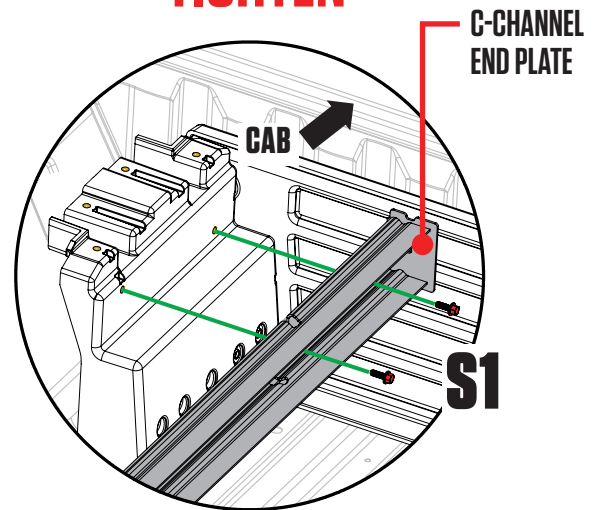

# INSTALL: DECK HALVES

- Loosely place driver side deck panel on driver side stud, center vert and ammo can.
- Shift ammo can forward, rearward, L-R, as necessary to align with fully seated deck panel.
- Loosely assemble:
  - Six bolts (without O-rings) through deck panel into center vert; BAG **S1**.
  - Four bolts with O-rings through deck panel into stud; BAG **S1**, BAG **O-RINGS**.
  - Eight bolts with O-rings through deck panel into ammo can; BAG **S1**, BAG **O-RINGS**.
  - Tighten all S1 bolts.
  - **Securely tighten driver side C-Channel/ammo can nut and bolt.**
- Repeat passenger side (**make sure you don't forget to securely tighten passenger side C-Channel/ammo can nut and bolt**).

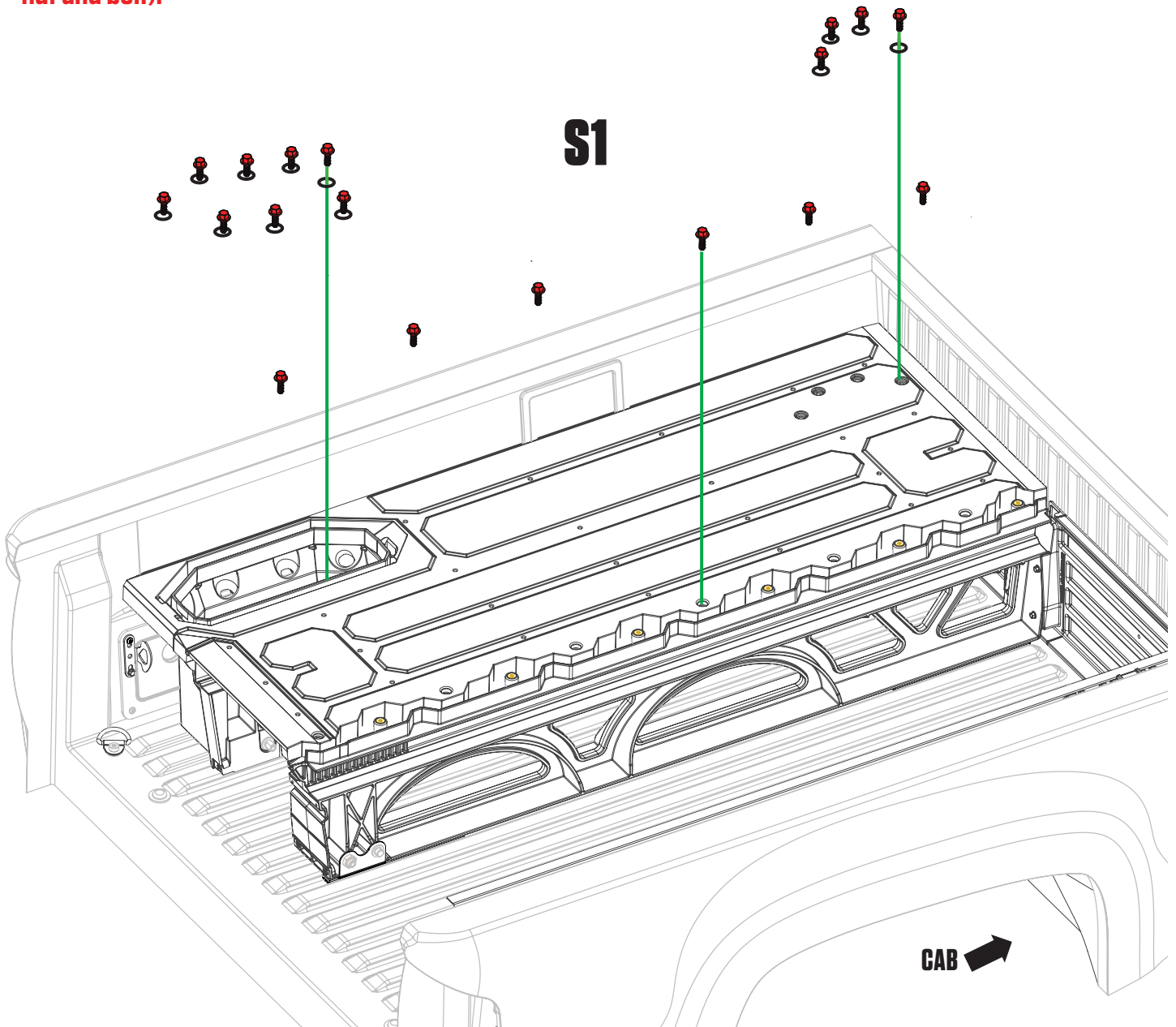

# INSTALL: J-HOOKS

- **Loosely** assemble driver side J-hook assembly in order shown through tailgate side hole in ammo can; BAG J5.
- Repeat passenger side.

**DRIVER SIDE AMMO CAN**  
**KEEP LOOSE**

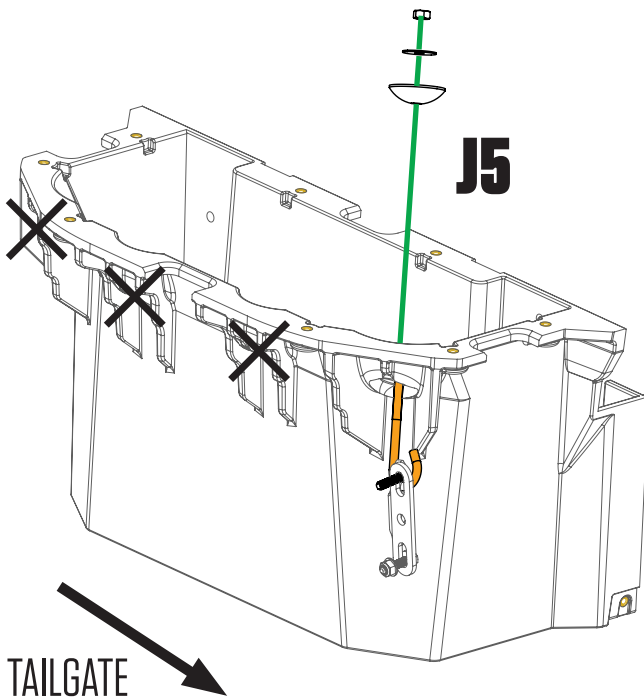

**PASSENGER SIDE AMMO CAN**  
**KEEP LOOSE**

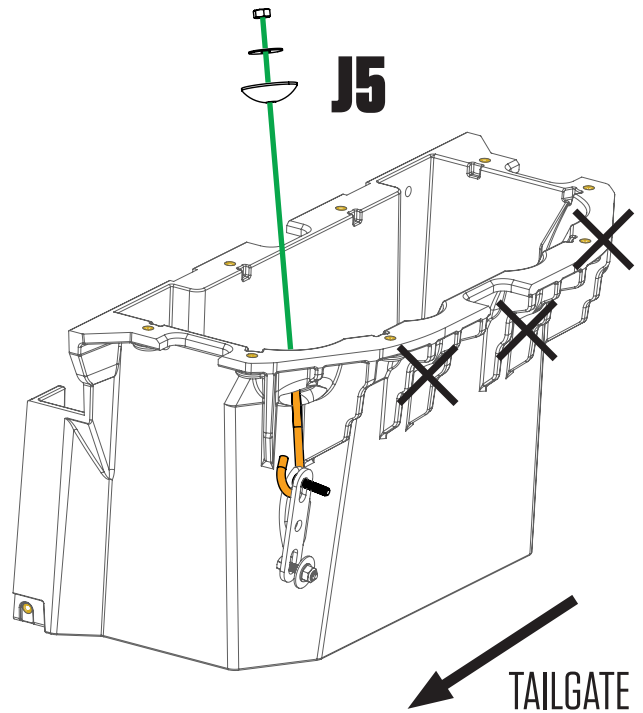

**HELPFUL TIP:** Make sure the hooks  
open toward tailgate.



# DRAWERS: BRACKETS + WHEELS

- Each drawer has a left and a right bracket. Bolt brackets into place via bottom two holes in bracket with 3/4" length bolts. Use the 2" length bolt for the upper cabside wall hole in bracket; BAG **DRAWER 1**.
- Install a tube brace in each drawer with two 3/4" length bolts; BAG **DRAWER 1**, BAG **DRAWER 2**.
- Attach wheels onto drawer brackets with a 7/32" hex wrench; BAG **WHEELS**.

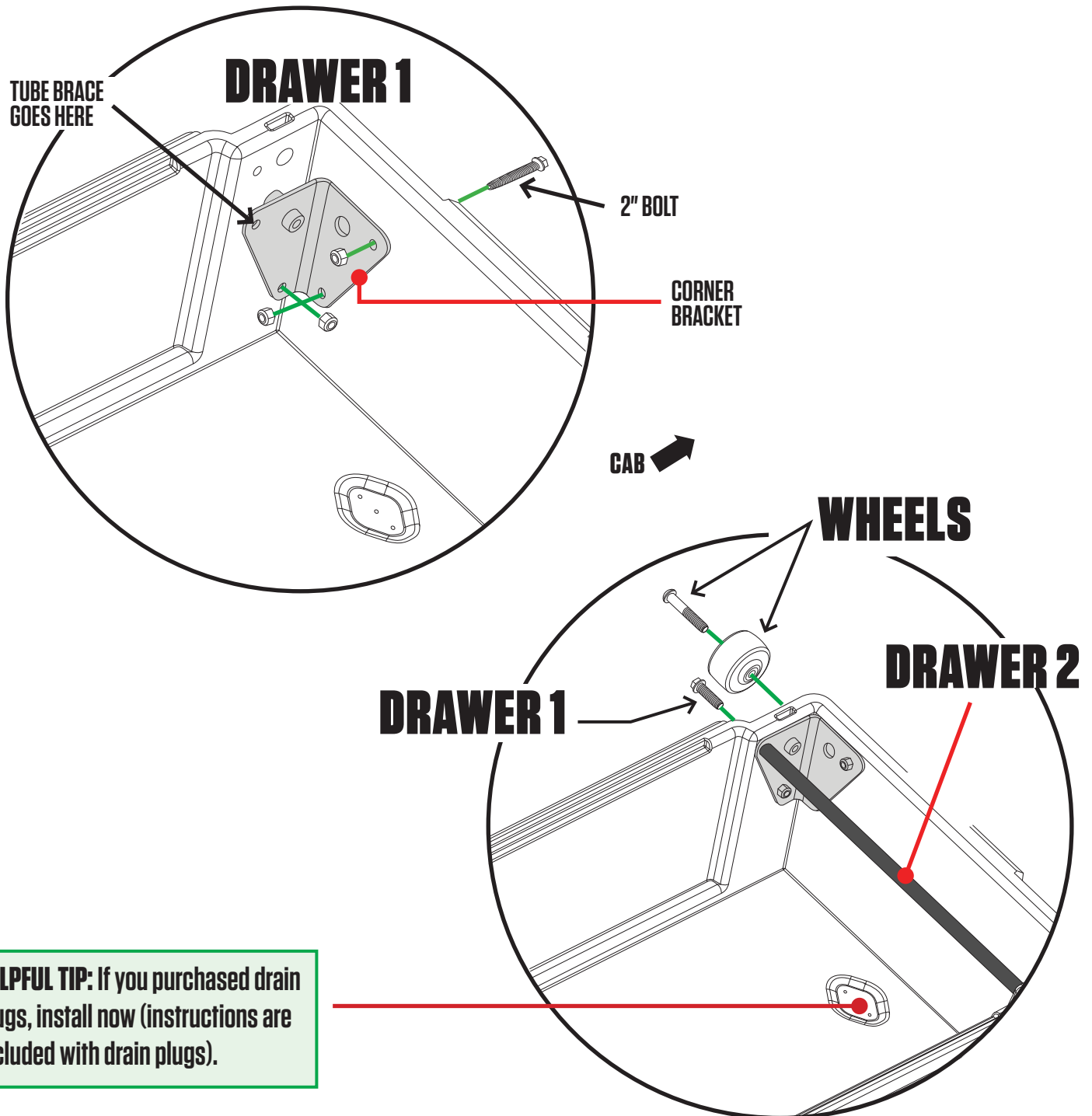

# DRAWERS: AXLE WHEELS + WEATHERSTRIPS

- Slide narrow drawer into driver side drawer cavity. **NOTE: It is easier to fully install narrow drawer first.**
- **DETAIL A:** Install two tailgate wheels onto narrow drawer axles with a 7/32" hex wrench; **BAG WHEELS.**
- Repeat with wide drawer.
- **DETAIL B:** Install weatherstrips on top of drawer edges **WITH WIPER BLADE POINTING TOWARD DRIVER.**  
**IMPORTANT: Facing the weatherstrip the wrong way will funnel water into drawer: DUH!**

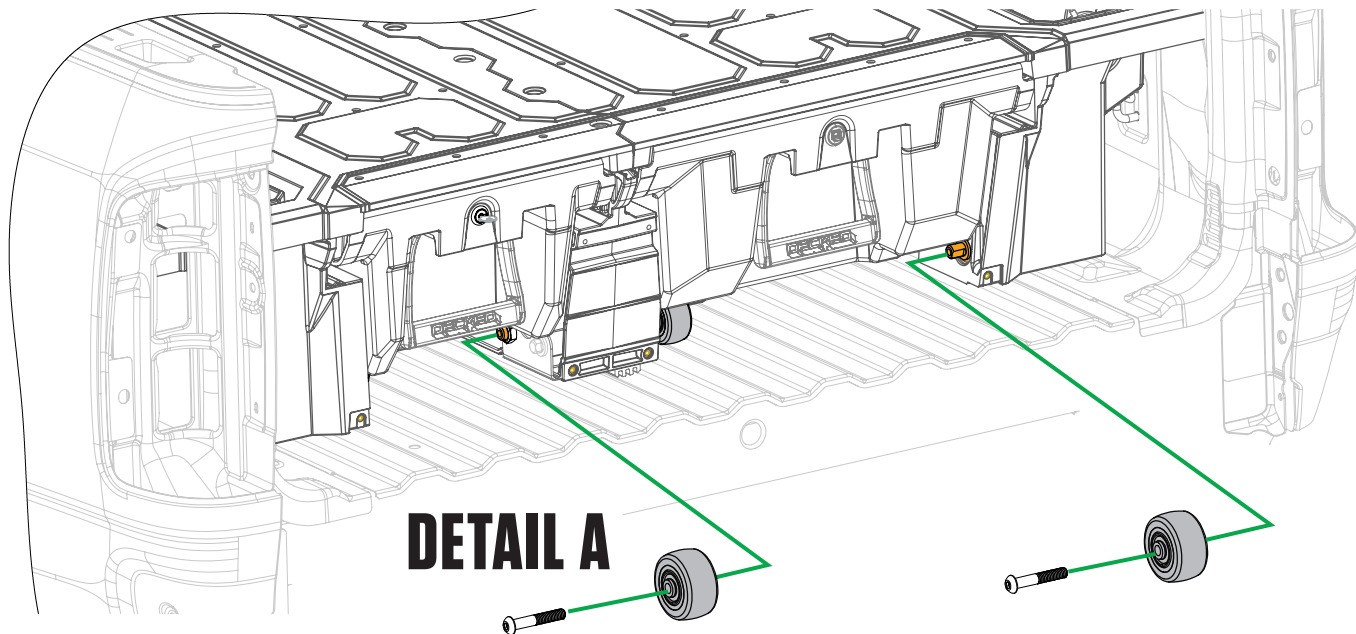

**HELPFUL TIP:** To make this step easier, jam a 2" piece of material under drawer, or get your pal to pinch the drawer up to the deck to give you better leverage.

**HELPFUL TIP:** Cut weatherstrips if they overhang.

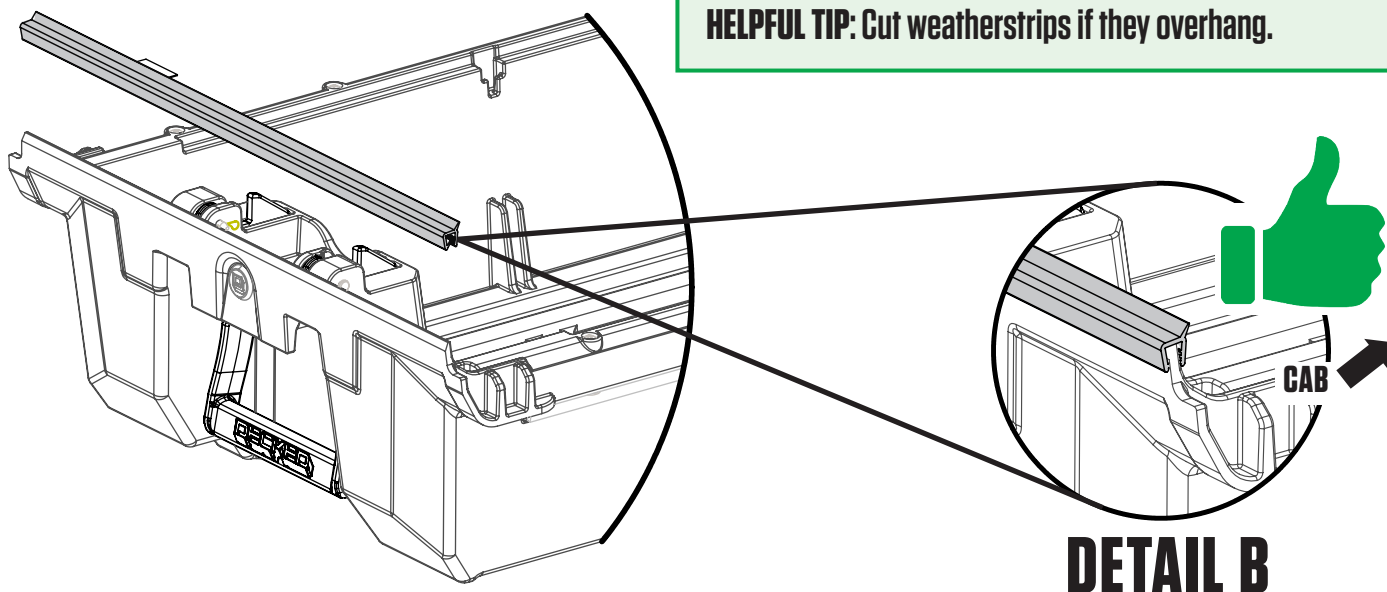

# FINAL STEPS: TORSION BRACE + BOTTLE OPENER

- Slide torsion brace under center vert and tailgate ammo cans.

**NOTE: If you jumped the gun and tightened the J-hooks when installing, loosen them.**

- Loosely install:

- Two bolts with nylon washers through the end holes in torsion brace into ammo cans; BAG **S1**.
- Two bolts with nylon washers through the bottom bottle opener holes and torsion brace into center vert; BAG **S1**.
- Two 1/2" length bolts through upper holes in bottle opener into center vert; BAG **FINAL MID**.

- Align bottle opener to edges of center vert and tighten four bottle opener bolts.

- Tighten end bolts into tailgate ammo cans.

- **Finally.....Tighten the J-hooks! DO NOT OVER TIGHTEN, just make snug. Make sure the gap between the sidewall of the bed and the deck is equal on both sides.**

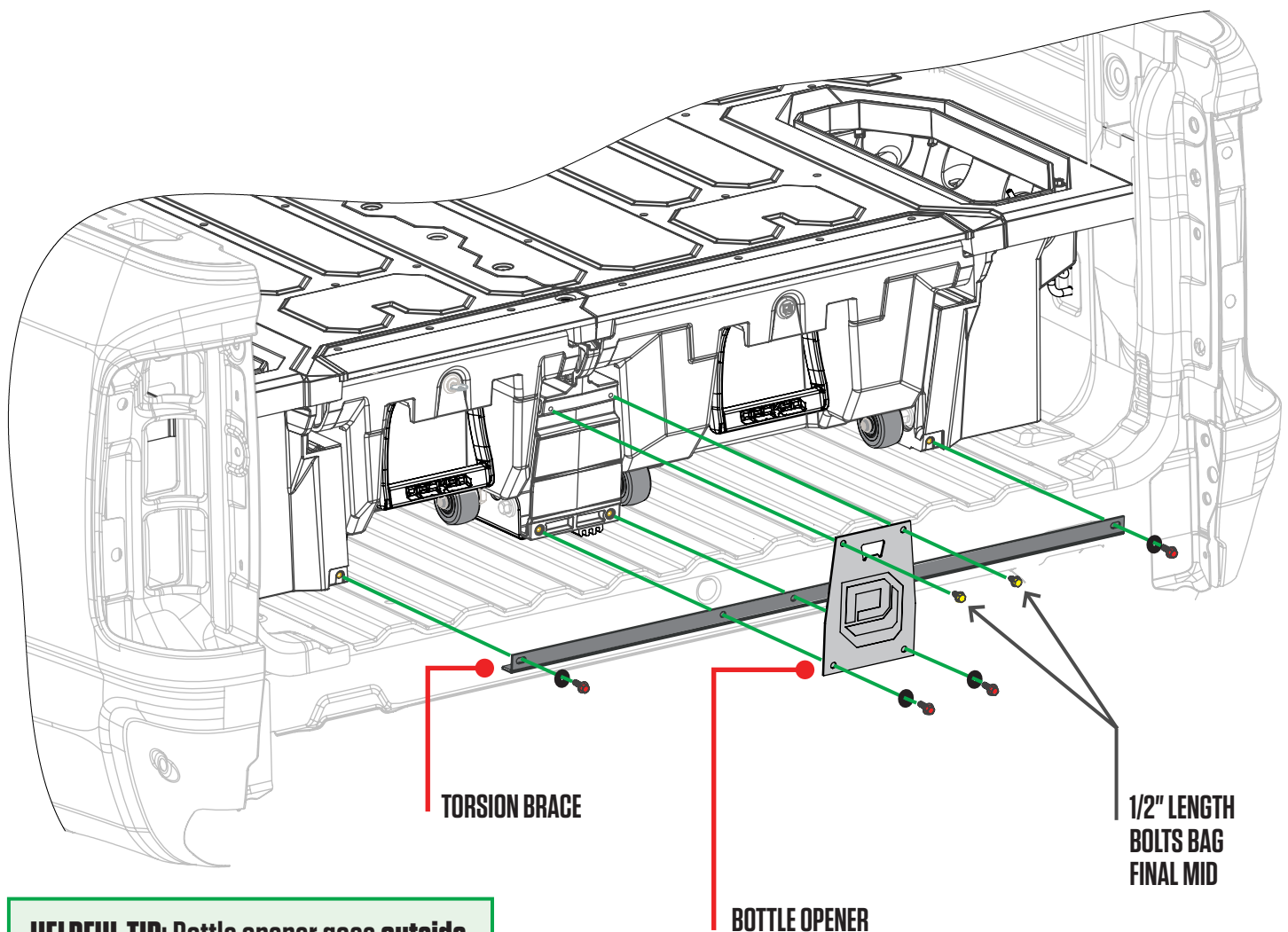

**HELPFUL TIP:** Bottle opener goes outside of torsion brace.

# BAM BAM: THE RULER

- Center ruler in embossed area and screw three 1/2" length Phillips screws through the tailgate side holes directly into deck panels; BAG **FINAL MID**.
- **NOTE: These are small gauge screws. Tighten to a light snuggle ONLY.**
- For the three cabside ruler mounting holes, drill each with a 9/64" bit and a drill stop set to 1/2". There is a lateral steel tube that runs on the underside of the deck at this location. (SEE UNDERSIDE VIEW OF DECK).
- **IMPORTANT: Only drill through TOP of steel tube; do not drill through bottom of tube, 'lest you want to pull a Niagara Falls and funnel water into your drawers.**
- Screw three 3/4" length Phillips screws into the cabside ruler holes you just drilled; BAG **FINAL MID**.

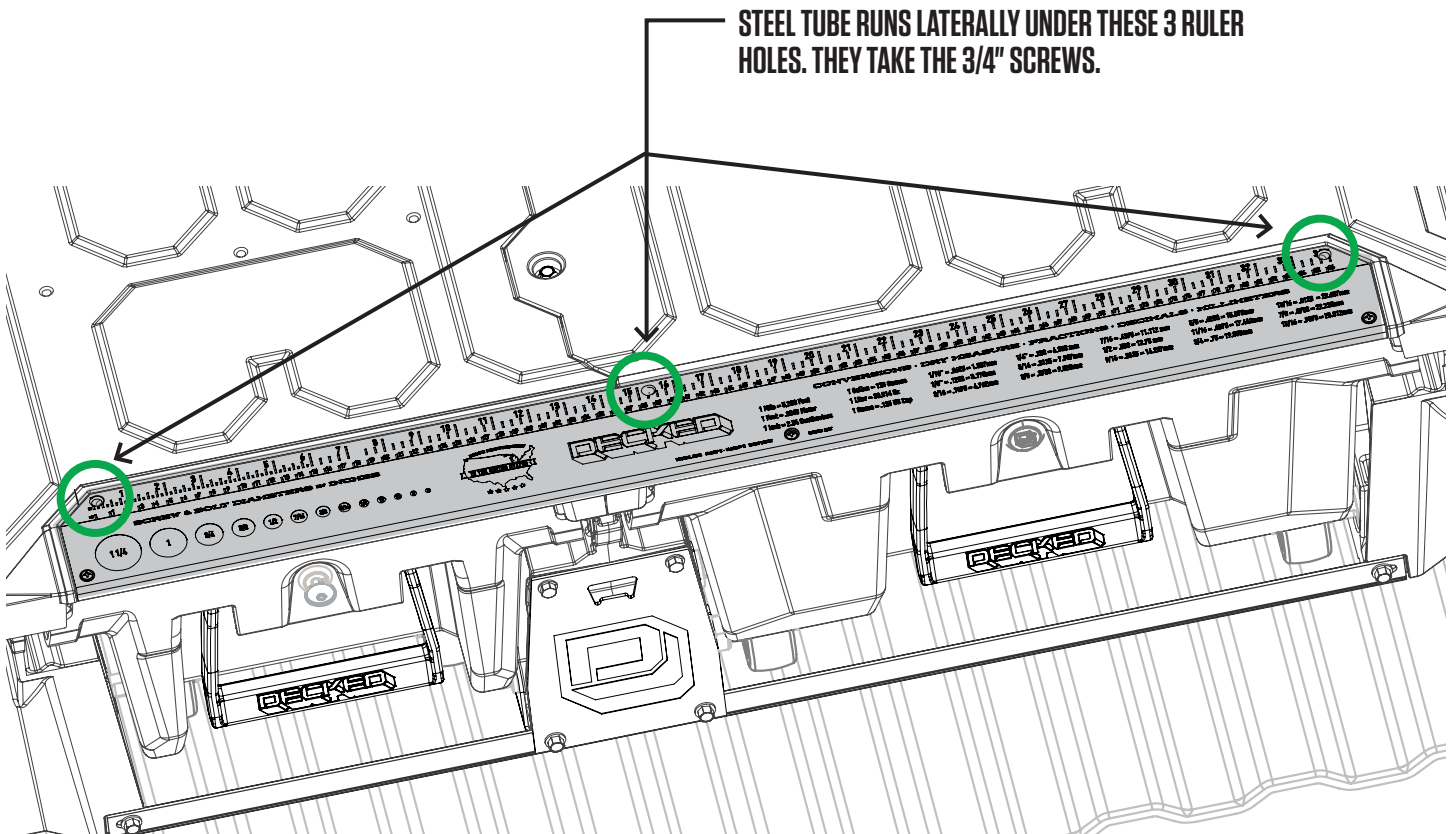

## UNDERSIDE VIEW OF DECK

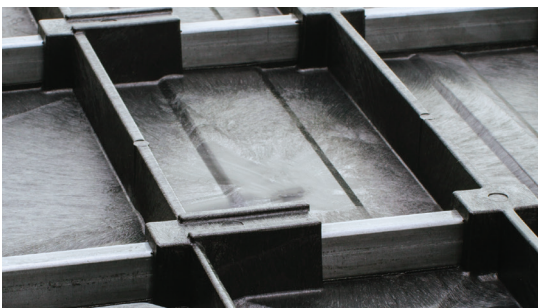

**DO:** Drill through the top of steel tube ONLY.

**DO NOT:** Drill through both sides of steel tube = **YOU'RE FIRED!**



# FINAL STEPS: AMMO CAN LIDS

- **DETAIL A:** Ammo can lids are driver (marked L) and passenger (marked R) side specific.
- **DETAIL B:** Holding lid in orientation shown, insert tab on tailgate end of ammo can lid and push the cabside end of lid down to secure. Don't be afraid to give'r the Fonzi to close, it's rugged.
- Insert lock hole plugs, unless you ordered drawer locks! Install drawer locks now (instructions with locks);  
**BAG FINAL MID.**

**IMPORTANT:** Grab your favorite beverage, crack 'er open in the bottle opener and christen this ship! You did it. Immediately post a photo of your significant other, child or canine (in no order of significance) appreciating your accomplishment. Add hashtag #DECKEDUSA | @DECKEDUSA.

## DETAIL A

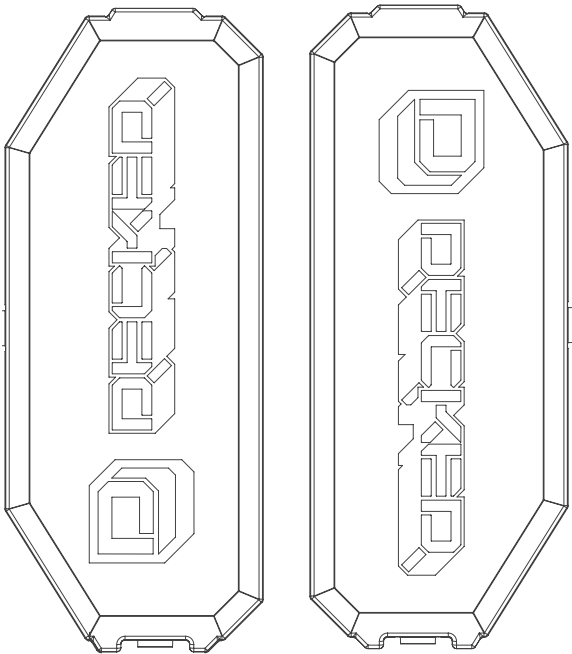

DRIVER SIDE  
AMMO CAN LID

PASSENGER SIDE  
AMMO CAN LID

## DETAIL B

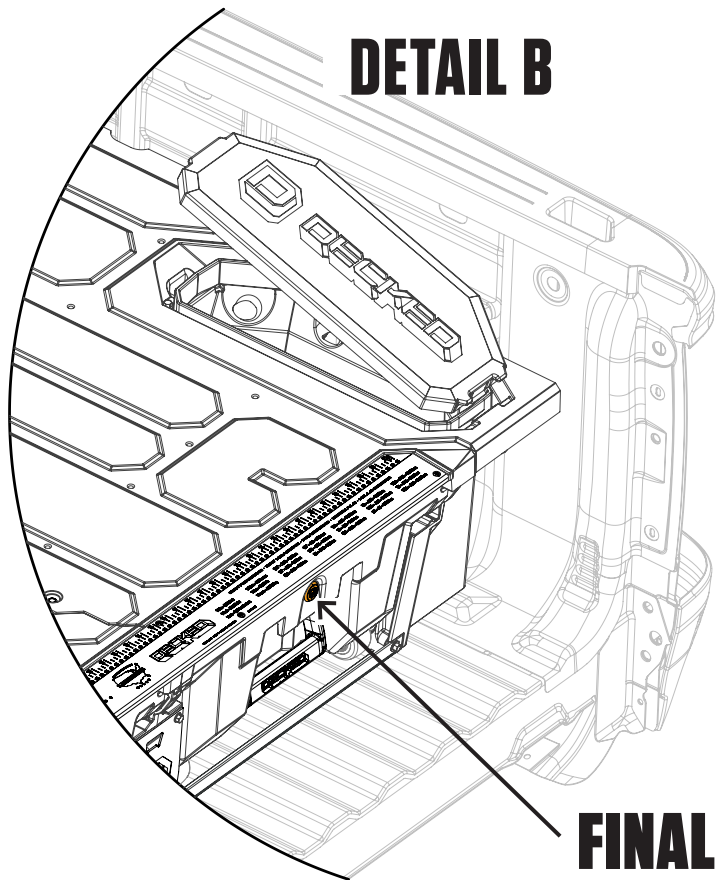

**FINAL MID**

# DECKED 3-YEAR LIMITED WARRANTY (a.k.a LEGAL MUMBO JUMBO)

DECKED LLC warrants to the original purchaser of this product that the product will be free from manufacturing defects in workmanship and materials for a period of three (3) years from the date of the original purchase. If within three (3) years from the original date of purchase this product fails due to defect in materials or workmanship, DECKED LLC will replace any defective part at its option.

The original purchaser must contact the DECKED LLC customer service team and provide a description of the defective part, including digital pictures if requested, with the original purchase documentation as validation of warranty coverage or have previously activated their warranty online.

This warranty DOES NOT cover or apply to:

- Damage to the product due to misuse, mishandling and abuse.
- Products not used in accordance with the manufacturer's instructions or recommendations.
- Product not assembled or installed according to manufacturer's instructions.
- Normal wear and tear.
- Undeclared damage to the system during shipping, acts of God. In addition, consequential damage and incidental damages (including lost time) such as damage to persons or property are not covered under this warranty.

REGISTER YOUR PRODUCT FOR ANY FUTURE WARRANTY NEEDS AS WELL AS TO BE INFORMED OF PRODUCT IMPROVEMENTS, ISSUES OR SOLUTIONS SPECIFIC TO YOUR MODEL [DECKED.COM/REGISTER](https://www.decked.com/register)

#DECKEDUSA | @DECKEDUSA