



KF04009 91-99 Ford Explorer Body Mount Kit

www.DaystarWeb.com
 Tech Support Contact Info
Tech@DaystarWeb.com
 Phone: 623.907.0081
 Fax: 623.907.0088
 841 South 71st Avenue
 Phoenix, AZ 85043

Bill Of Material		
M02545	Bushing	4
M02539	Bushing	2
M02540	Bushing	2
M02541	Bushing	2
M02542	Bushing	4
M02543	Bushing	4
M02544	Bushing	2
M02546	Bushing	4
S10126	Washer	2

Mounting Order From Front to Rear	
Above Frame	Below Frame
1. M02539	M02540
2. M02541	M02543
3. M02545	M02546
4. M02544	M02543
5. M02545	M02546

INSTRUCTIONS: Please read completely before beginning installation.

- Note all body mount positions and respective parts (mount size, type, washers, **spacers, bolts**, shims etc.) before and during disassembly. You may have to reuse certain factory hardware pieces that are not included in this kit.
- If mounting bolts and nuts are rusted, liberally spray with penetrating oil.
- Support vehicle body properly before removing mounts. Use a 2x4 about 2 long (or any other suitable size) between jack and body panel to spread the weight load out so as not to damage the body. If needed, support the body in several areas.
- Loosen all bolts and nuts but do not remove.
- Working on one side of vehicle at a time, remove mounting bolt and nut and raise body only high enough to replace mount, never higher. Also check other areas on body and frame to avoid any interference problems when raising body. See Fig. 1.
- Replace mounts one at a time. After all mounts have been replaced torque bolts to factory specifications.
- After driving vehicle for about 500 miles, re-torque bolts again. This is to insure that the bolts have not loosened due to initial settling that may take place.

Some Fords use a unique one piece stamped washer and sleeve assembly. This type of assembly can sometimes be difficult to remove, especially on older vehicles. Use Fig. 2 and the instructions below to facilitate disassembly.

- Remove body mount bolt from inside of cab.
- Thread the bolts back in from below into bottom washer/sleeve assembly until bolt is flush with inside of washer. This is to protect the threads during removal.
- Insert a 10" long x 1/2" or equivalent punch into body mount from inside cab. Drive bottom washer/sleeve assembly downward away from top assembly with a hammer.
- The lip on the bottom stamped washer/sleeve assembly may become mushroomed, especially on older vehicles. Before reinstalling this part, remove mushroomed lip to avoid any interference fit problems.

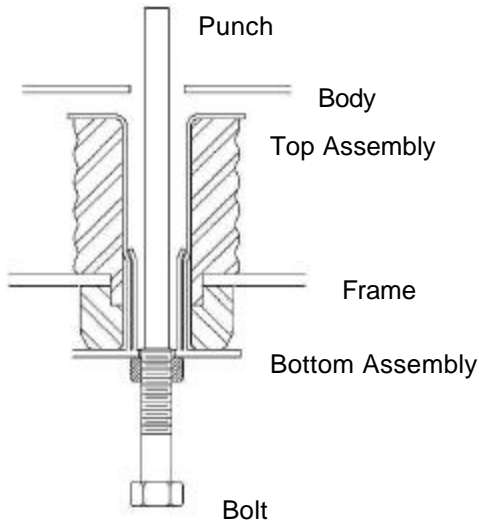

WARNING

This vehicle has been modified to enhance its performance. The steering, braking and handling of this vehicle will differ from standard passenger cars and trucks. This vehicle handles differently from an ordinary vehicle in driving conditions which may occur on streets, highways and off road.

Avoid unnecessary abrupt maneuvers, sudden stops, sharp turns and other driving conditions that could cause loss of control, possibly leading to a roll over or other accident that could result in serious injury or death to driver and passengers.

If larger tires are installed the speedometer will read lower than the vehicles actual speed.

DRIVE WITH CARE, REDUCE SPEED AND WEAR SEAT BELTS AT ALL TIMES.

This kit should be installed by a professional mechanic.

