

INSTALLATION INSTRUCTIONS

FRONT FENDERS

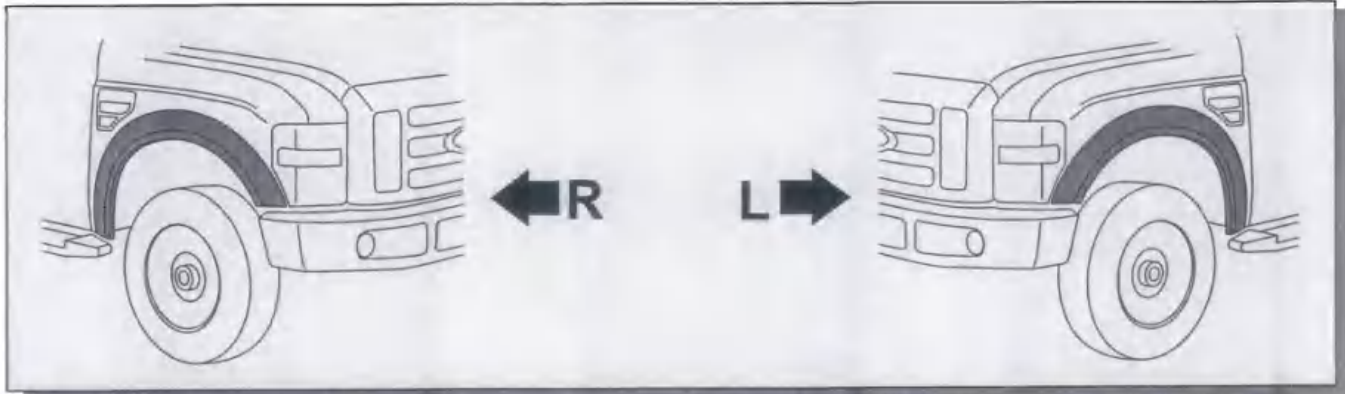

1. Ensure that both left and right hand Fender Flares suit the profile of the vehicle. Note the areas where the Fender Flares come in contact with the vehicle. **NOTE:** Before fitting Fender Flares remove any mouldings, strips or existing flares from the wheel arch. If there is a body side moulding, mark where the moulding is to be cut, alternatively the Fender Flares can be cut to go around the moulding. Be sure to allow enough room for the extrusion.

PAINTING INSTRUCTIONS – If Fender Flares are being painted, do not install edge extrusion until painting is complete. Prior to painting, clean all surfaces to be painted using clean water and a mild detergent, do not use lacquer thinner or any solvent based products. Wipe completely dry. Best results will be achieved by wiping the areas to be painted with a tack rag just prior to painting. Most automotive paints can be applied directly to the Fender Flares, however some may require a primer (check paint manufacturer specifications). Good adhesion will be achieved without sanding. Select a paint (and primer if necessary) that is suitable for rigid plastics PMMA (Acrylic). If using a paint system which requires baking, do not expose the product to temperatures above 70°C (158°F). Do not fit the extrusion or any of the hardware to the Fender Flares until the paint is completely dry.

IMPORTANT: For bolt-on Fender Flares proceed to Step 2. For rugged Fender Flares proceed to Step 3.

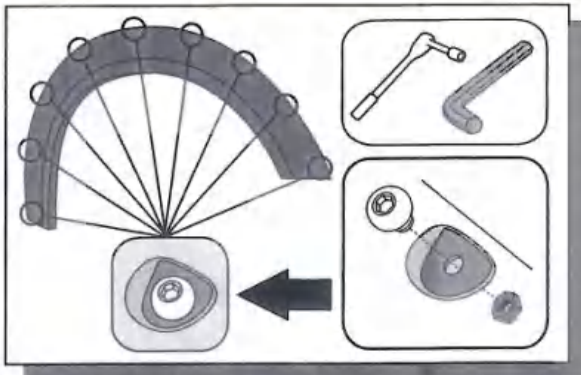

2. Attach 9 bolts to each Fender Flare using a 3/16" Allen key and a 1/2" wrench/socket. (socket wrench and Allen key not supplied)

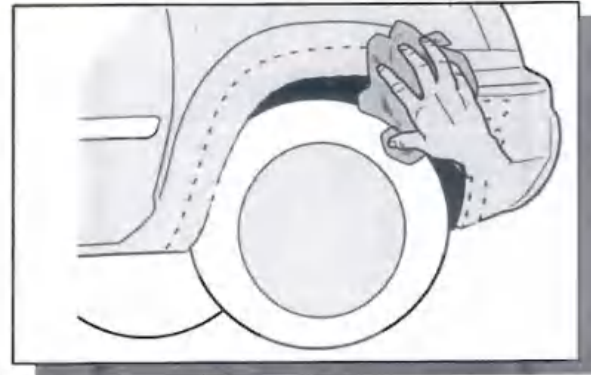

3. Wash the areas of contact on the vehicle and wipe dry both the vehicle and the Fender Flares with a clean cloth. Ensure inside of Fender Flares where extrusion is attached is clean, use alcohol wipe supplied to clean surface.

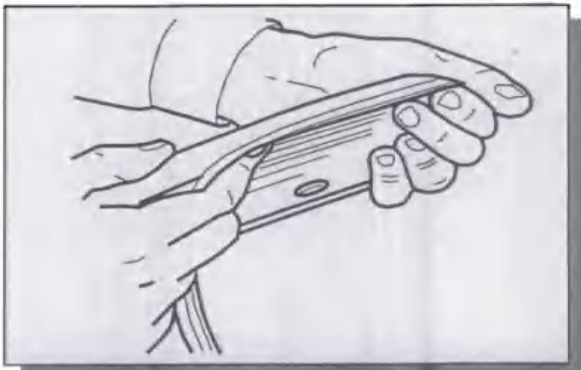

4. Remove approximately 2" (50mm) of the protective liner from the extrusion. Fit the extrusion to the Fender Flare along the edge that comes in contact with the

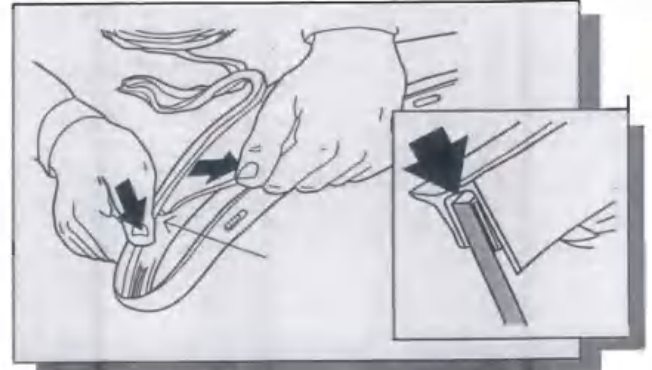

5. Pulling at right angles to the extrusion, remove the liner from the extrusion in small portions and apply thumb pressure to ensure that it adheres to the

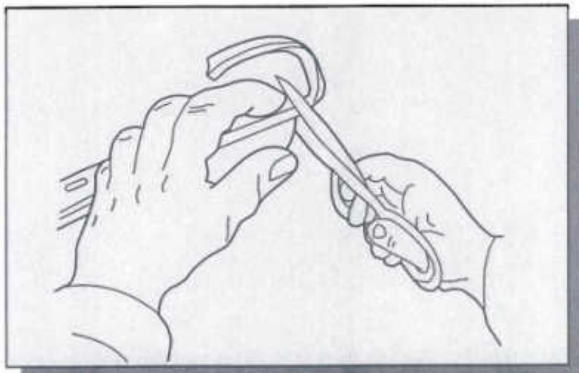

- 6.** Trim any unnecessary extrusion and discard.

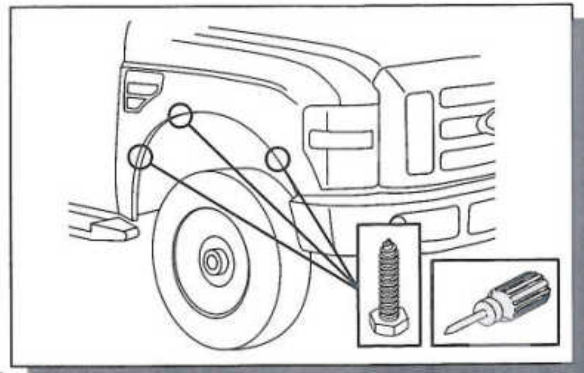

- 7.** Use the original manufacturer's hardware that is in the wheel arch of the vehicle to fit the Fender Flares. Remove the 5.5mm socket head screws from the fasteners on the vehicle.

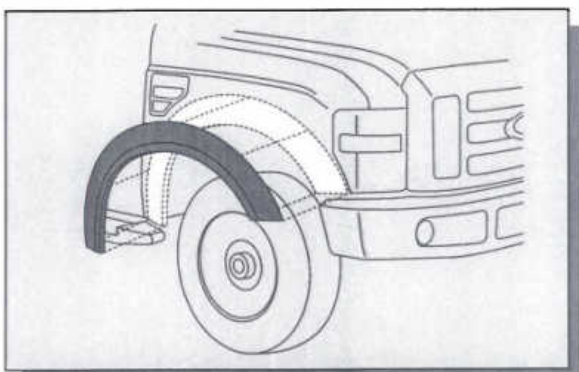

- 8.** Place the front Fender Flares onto the vehicle and line up the holes on the part with the screw holes on the vehicle.

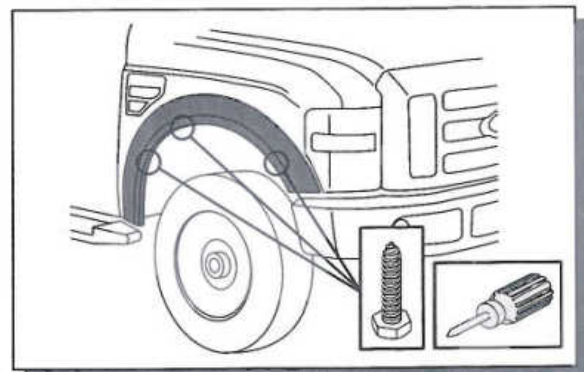

- 9.** Re-Install the socket head screws into the fender to secure the Fender Flares. Fit the Fender Flares loosely until the Fender Flares are aligned as desired, when satisfied, tighten the screws fully and ensure extrusion is flush neatly against the body.



CLEAN FLARES
WITH MILD
DETERGENT
ONLY, NO
ABRASIVE
CLEANERS.

FENDER FLARES

INSTALLATION INSTRUCTIONS

REAR FENDERS

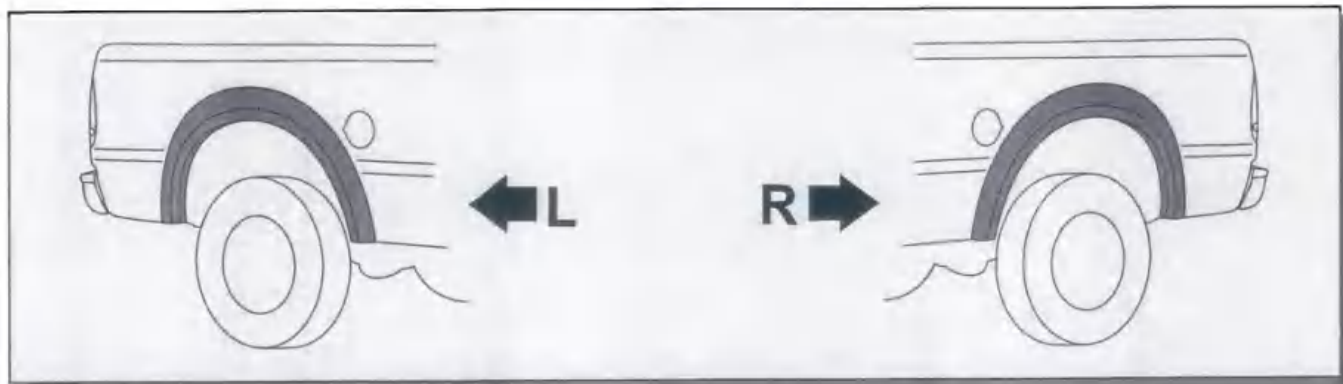

1. Ensure that both left and right hand Fender Flares suit the profile of the vehicle. Note the areas where the Fender Flares come in contact with the vehicle. **NOTE:** Before fitting Fender Flares remove any mouldings, strips or existing flares from the wheel arch. If there is a body side moulding, mark where the moulding is to be cut, alternatively the Fender Flares can be cut to go around the moulding. Be sure to allow enough room for the extrusion.

PAINTING INSTRUCTIONS – If Fender Flares are being painted, do not install edge extrusion until painting is complete. Prior to painting, clean all surfaces to be painted using clean water and a mild detergent, do not use lacquer thinner or any solvent based products. Wipe completely dry. Best results will be achieved by wiping the areas to be painted with a tack rag just prior to painting. Most automotive paints can be applied directly to the Fender Flares, however some may require a primer (check paint manufacturer specifications). Good adhesion will be achieved without sanding. Select a paint (and primer if necessary) that is suitable for rigid plastics PMMA (Acrylic). If using a paint system which requires baking, do not expose the product to temperatures above 70°C (158°F). Do not fit the extrusion or any of the hardware to the Fender Flares until the paint is completely dry.

IMPORTANT: For bolt-on Fender Flares proceed to **Step 2**. For rugged Fender Flares proceed to **Step 3**.

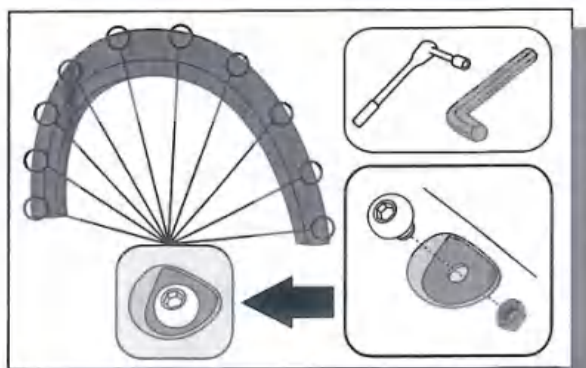

2. Attach 10 bolts to each Fender Flare using a 3/16" Allen key and a 1/2" wrench/socket. (socket wrench and Allen key not supplied)

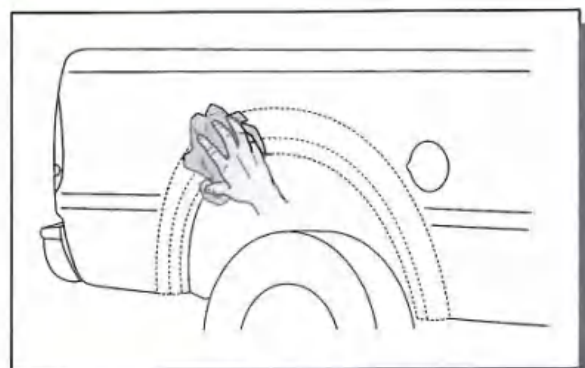

3. Wash the areas of contact on the vehicle and wipe dry both the vehicle and the Fender Flares with a clean cloth. Ensure inside of Fender Flares where extrusion is attached is clean, use alcohol wipe supplied to clean surface.

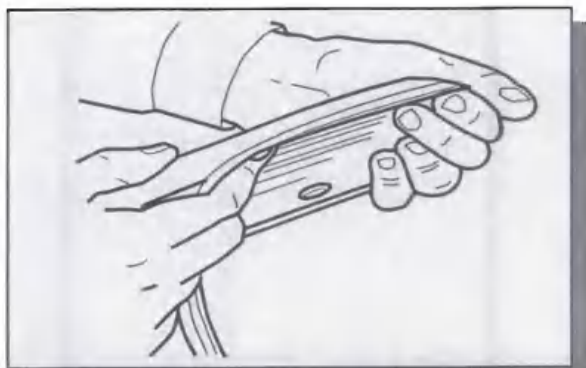

4. Remove approximately 2" (50mm) of the protective liner from the extrusion. Fit the extrusion to the Fender Flare along the edge that comes in contact with the vehicle's body panel.

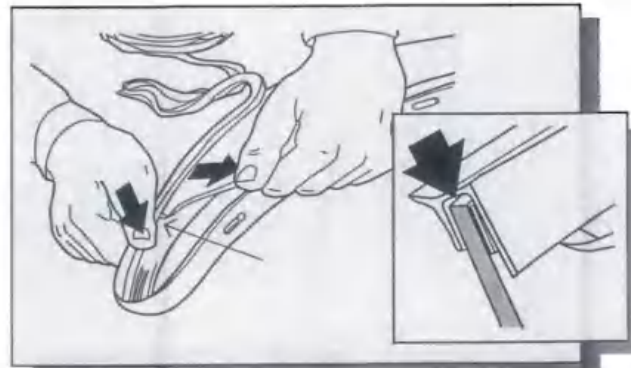

5. Pulling at right angles to the extrusion, remove the liner from the extrusion in small portions and apply thumb pressure to ensure that it adheres to the Fender Flare.

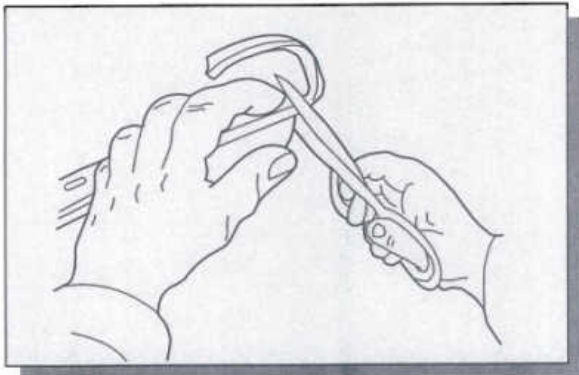

6. Trim any unnecessary extrusion and discard.

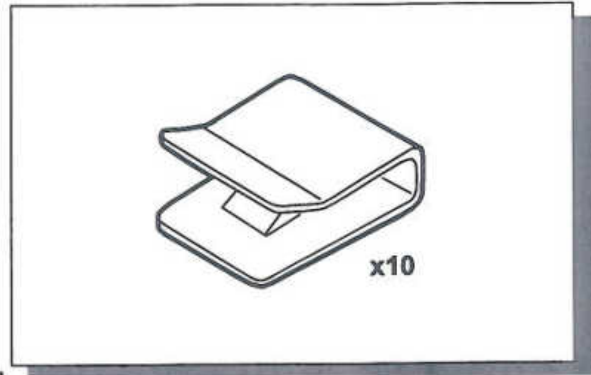

7. Ensure that all of the necessary hardware is in the hardware kit.

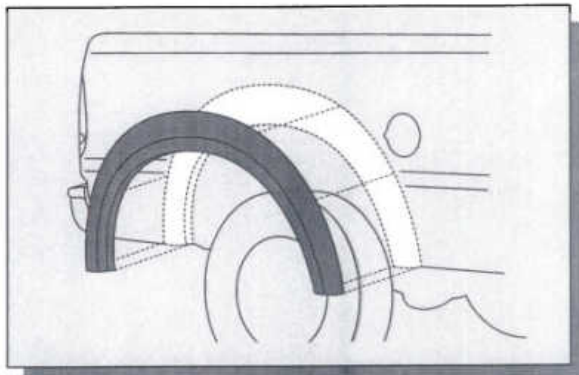

8. Position the Fender Flare into the position of best fit.

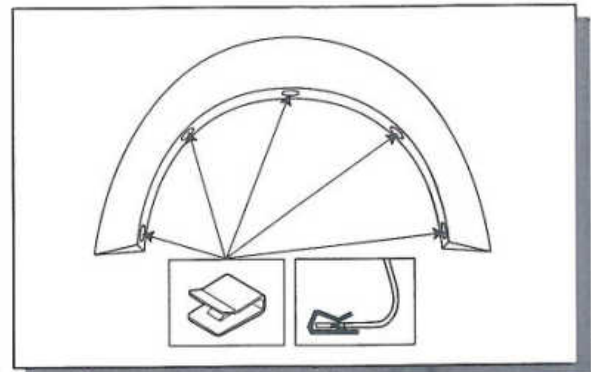

9. Correct hardware positions. When installing clips, ensure the raised barb in the clip engages in the cut slot of the Flare. You may hear a snapping or popping noise when this occurs.

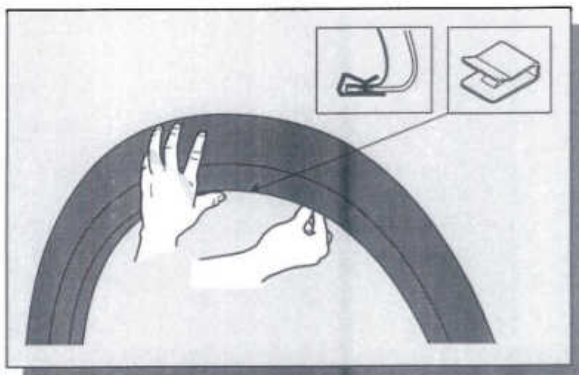

10. Take one snap on clip and insert it to the top of the flare as shown. Apply pressure to the Fender Flare to assist with the installation of these clips.

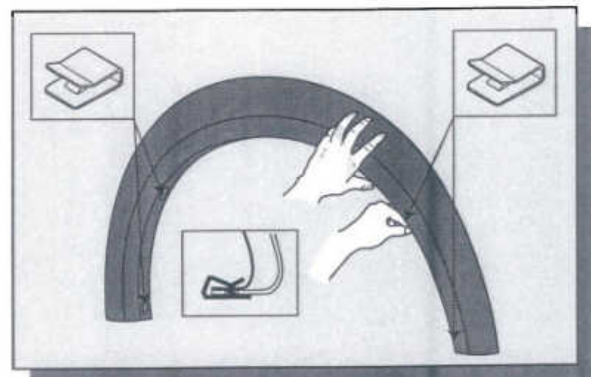

11. Insert clips as shown

