



Revised: 01/29/2001

Explorer Competition Products, Inc. Chula Vista, CA USA

Ph: (619) 216-1444 • Fax: (619) 216-1474 • E-Mail: tech@explorerprocomp.com • Website: www.explorerprocomp.com

# INSTALLATION INSTRUCTIONS

## Part # 2508

PLEASE READ ALL INSTRUCTIONS FROM START TO FINISH BEFORE YOU BEGIN INSTALLATION

- 1) Place wheels in straight ahead position.
- 2) This kit is used on many different vehicles, choose the illustration which is like your vehicle.
- 3) Install axle bracket A upon axle housing tube per illustration. Install u-bolt and nuts but do not tighten yet.
- 4) Install one end of cylinder on bracket A per the illustration, paying special attention to whether it is the cylinder or rod end.
- 5) Install the other end of cylinder to bracket B per the illustration.
- 6) Pull the cylinder rod out four inches and install bracket B to tie rod using U-bolts and nuts supplied.
- 7) Rotate the axle bracket and the tie rod bracket so the smaller rod end of the cylinder is higher than the larger O.D. end to the cylinder.
- 8) Fully tighten both brackets at this time.
- 9) Turn the wheels all the way right and all the way left and be sure there is no interference or binding.
- 10) Inspect all nuts used in installation for tightness periodically.

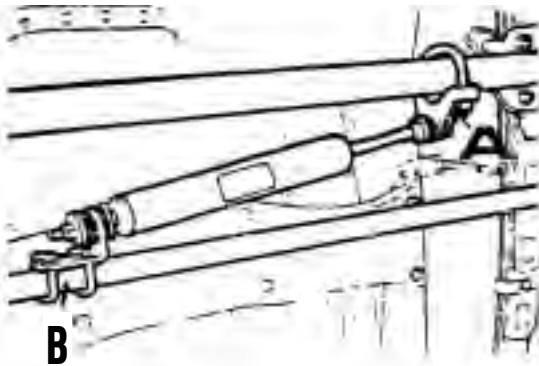

ILLUSTRATION A - 1 beam straight axle 2WD (common to international, early Ford pickups and vans, GMC, Chevrolet and Jeep pickups).

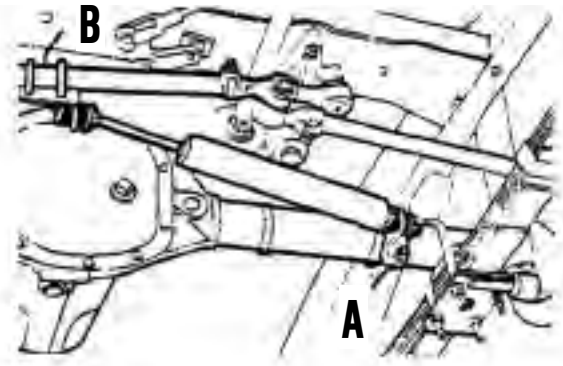

ILLUSTRATION 2 - Jeep up to 1970 (before Jeep started using a long single relay rod).

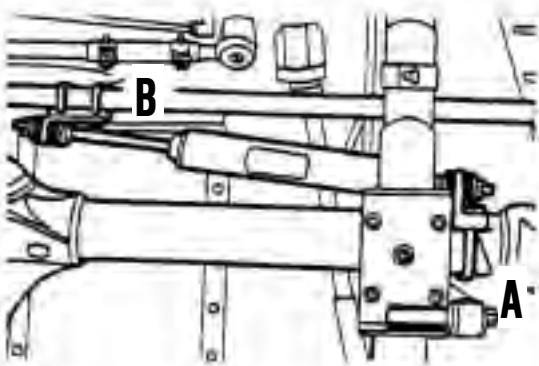

ILLUSTRATION 3 - GMC, Chevrolet, and early Scout.

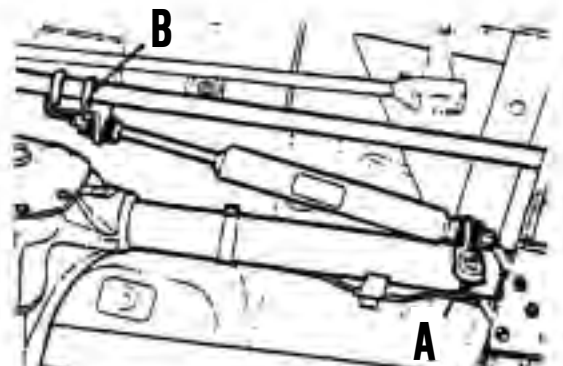

ILLUSTRATION 4 - 1970-75 Jeeps