

2360 Boswell Road  
Chula Vista, CA 91914  
Phone 619.216.1444  
Fax 619.216.1474  
E-Mail tech@explorerprocomp.com



## PRO COMP SUSPENSION

---

### Suspension Systems that Work!

**Attention:** It is imperative that you use only the specified PRO COMP shocks with these hoops. If any other shock other than PRO COMPS are used, it may cause premature failure of the factory and/or pro comp suspension parts. It will also void any and all warranties. Suspension component failure may result in injury or death.

**Part # 51294**  
**CHEVROLET DOUBLE SHOCK**  
**HOOP**

**NOTE : THIS KIT IS TO BE USED ONLY WITH  
PRO COMP SUSPENSION KITS: 51093, 51094,  
51088, 51098.**

This document contains very important information that includes warranty information and instructions for resolving problems you may encounter. Please keep it in the vehicle as a permanent record.

Box 1 of 2-PN 51294-1

Part #	Description	Qty.	Illus.	Page
90-2363	SHOCK HOOP	2	5	5
90-2365	CENTER SUPPORT BRACE (DRVR.)	1	-	-
90-2368	CENTER SUPPORT BRACE (PASS.)	1	5A,5B,6	6
90-1302	HORSESHOE CLAMP	2	1	4
90-1321	LOWER SHOCK MOUNT (PASS.)	1	1,7	4,6
90-1322	LOWER SHOCK MOUNT (DRVR.)	1	1,7	4,6
90- 6288	HARDWARE PACK CONTAINING:		-	-
90-2159	Sleeve, 5/8" x 7/8" Lg.	6	1	4
54314	1/2" x 5/8" x 1.480" Shock Sleeve	8	-	-
90-1442	WASHER - 1.280" O.D. X .5	4	7	5
90-1820	CAM BLOCK OFF PLATES	4	4	5
90-6029	BRAKELINE KIT	1	-	6,7
90- 6289	HARDWARE PACK CONTAINING:	1	-	-
70-0506501800	1/2" X 6 1/2" USS GR. 8 HEX	4	6,7	6
70-0504501800	1/2" X 4 1/2" USS GR. 8 HEX	2	5B,6	5
72-050100816	1/2" USS STOVER NUT	4	5B,6,7	6
73-05600832	1/2" USS Flat Washer	8	5B,6,7	6
70-0565501800	9/16" X 5 1/2" USS GR. 8 Hex	4	4	5
72-056100816	9/16" USS STOVER NUT	4	4	6
73-05600832	9/16" USS Flat Washer	8	4	6
70-037200150	3/8" x 2" USS GR. 5 Hex	6	1	4
72-03700100512	3/8" USS GR. 5 Nyloc Nut	6	1	4
73-03700030	3/8" SAE Flat Washer	12	1	4

**Attention:** It is imperative that you use only the specified PRO COMP shocks with these hoops. If any other shock other than PRO COMPS are used, it may cause premature failure of the factory and/or pro comp suspension parts. It will also void any and all warranties. Suspension component failure may result in injury or death.

PRO COMP SHOCKS ARE REQUIRED FOR THIS INSTALLATION.

- |                |                       |
|----------------|-----------------------|
| (4) PN 120500  | ES 1000 Series Shocks |
| (4) PN 320500  | ES 3000 Series Shocks |
| (4) PN 920500  | ES 9000 Series Shocks |
| (4) PN MX6088  | MX-6 Series Shocks    |
| (4) PN MX6064R | MX Reservoir Shocks   |
| (4) PN EXP3906 | Reservoir Shocks      |

## Introduction:

- ◆ **This installation requires a professional mechanic!**
- ◆ We recommend that you have access to a Chevrolet service manual for your vehicle to assist in the disassembly and reassembly of your vehicle. It contains a wealth of detailed information.
- ◆ Prior to installation, carefully inspect the vehicle's steering and driveline systems paying close attention to the tie rod ends, ball joints, wheel bearing preload, pitman and idler arm. Additionally, check steering-to-frame and suspension-to-frame attaching points for stress cracks. The overall vehicle must be in excellent working condition. Repair or replace all worn or damaged parts!
- ◆ Read the instructions carefully and study the illustrations before attempting installation! You may save yourself a lot of extra work.
- ◆ Check the parts and hardware against the parts list to assure that your kit is complete. Separating parts according to the areas where they will be used and placing the hardware with the brackets before you begin will save installation time.
- ◆ Check the special equipment list and ensure the availability of these tools.
- ◆ Secure and properly block vehicle prior to beginning installation.
- ◆ **ALWAYS** wear safety glasses when using power tools or working under the vehicle!
- ◆ Use caution when cutting is required under the vehicle. The factory undercoating is flammable. Take appropriate precautions. Have a fire extinguisher close at hand.
- ◆ Foot pound torque readings are listed on the Torque Specifications chart at the end of the instructions. These are to be used unless specifically directed otherwise. Apply thread retaining compound where specified.
- ◆ *Please note that while every effort is made to ensure that the installation of your Pro Comp lift kit is a positive experience, variations in construction and assembly in the vehicle manufacturing process will virtually ensure that some parts may seem difficult to install. Additionally, the current trend in manufacturing of vehicles results in a frame that is highly flexible and may shift slightly on disassembly prior to installation. The use of pry bars and tapered punches for alignment is considered normal and usually does not indicate a faulty product. However, if you are uncertain about some aspect of the installation process, please feel free to call our tech support department at the number listed on the cover page. We do not recommend that you modify the Pro Comp parts in any way as this will void any warranty expressed or implied by the Pro Comp Suspension company.*

### Optional Equipment Available from your Pro Comp Distributor!

Traction Bars	PN 71000
Skid Plate	PN 51188 (6 INCH), 51190 (4 INCH)
Pro Runner Style Light Bar	PN 14000 (Black), 14000G (Grey)
Hoop Style Light Bar	PN 21400 (Black), 21400G (Grey)

**Also, check out our outstanding selection of Pro Comp tires to compliment your new installation!**

## Installation

1. Work on one side of the vehicle at a time.
2. Raise and support the vehicle. Remove the wheels from the front of the vehicle.
3. If you have aftermarket upper ball joints, now would be a good time to install a 90 degree grease fitting to the top of the ball joint. This will allow you to lubricate the ball joint with the lower shock mount installed.
4. Using the .800" sleeves (90-2159), and the 3/8" hardware install lower shock mount, passenger side (90-1321) or driver side (90-1322), and the 90-1302 HORSE SHOE CLAMP, to upper control arm as show in ILLUSTRATION 1. Make sure that the lower shock mount base seats and indexes properly

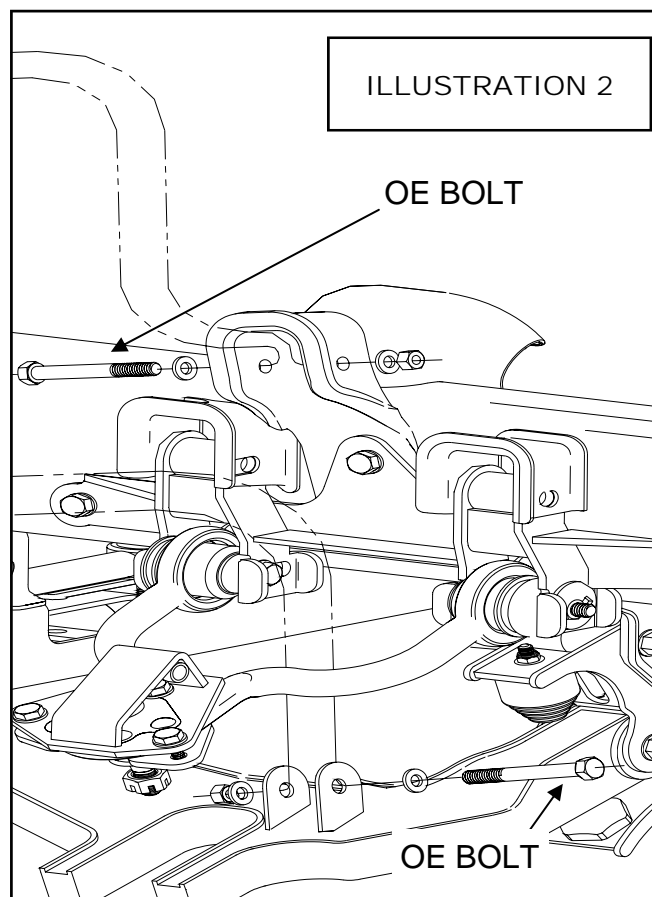
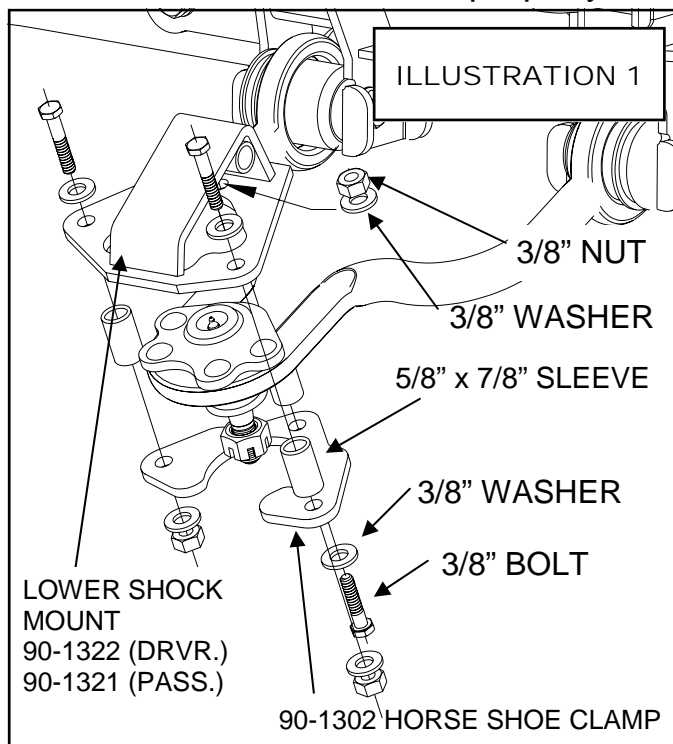

5. Torque the 3/8" hardware on the lower shock mount to 28 Ft. Lbs.
6. Install the single shock in the factory location as shown in ILLUSTRATION 2. Torque the single shock to factory specifications.
7. Remove the two upper existing bolts that hold the upper control arm drop bracket as shown in ILLUSTRATION 4. (Existing cam bolt location).
8. Temporarily install shock hoops driver side (90-2363) and passenger side (90-2363) as shown. Install the supplied 9/16"

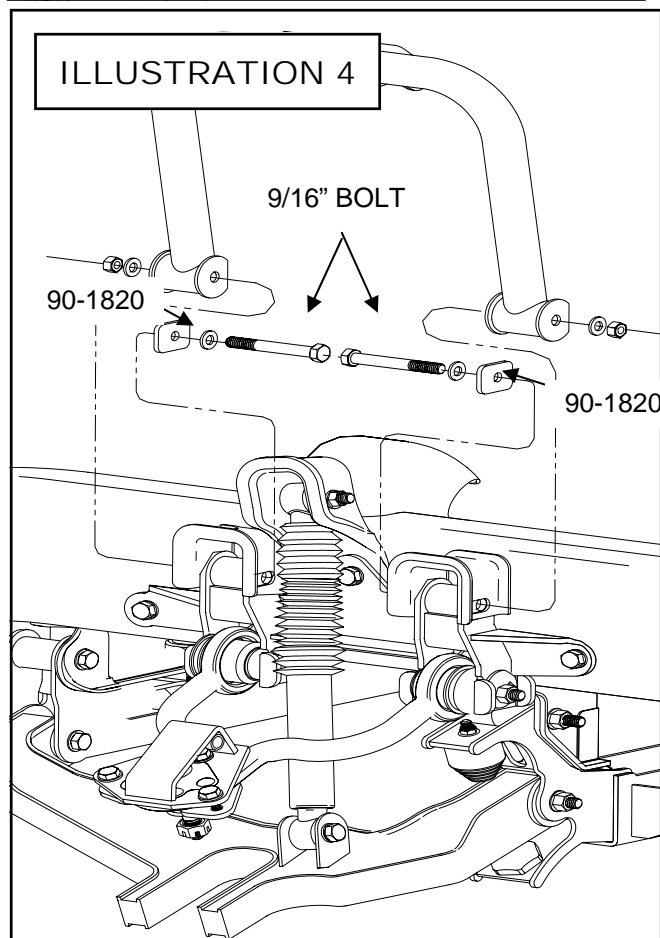
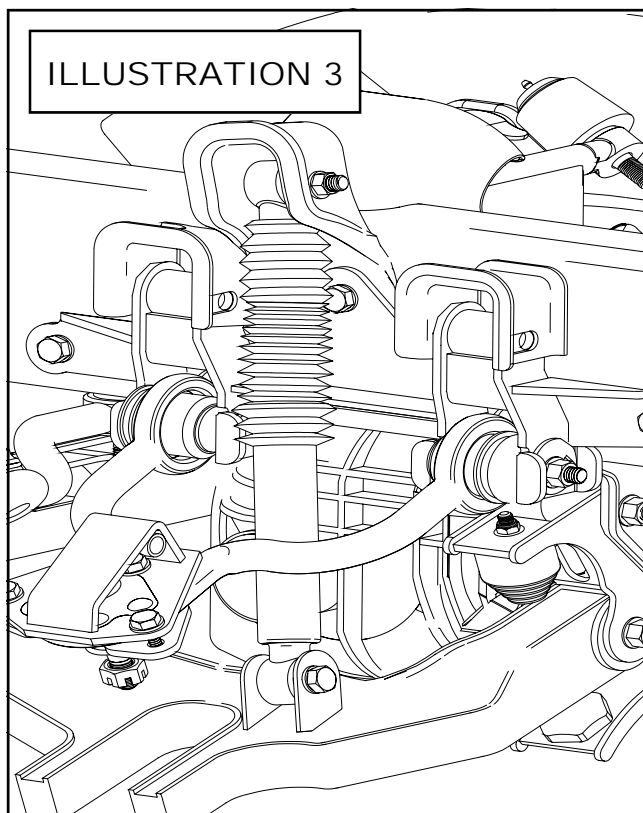

- hardware provided. Make sure the 90-1820 cam block off plate is installed on the inside of the arms, against the frame. Do not tighten at this time. See ILLUSTRATION 4.
9. Place the center brace support, 90-2365(DRVR.) and 90-2368(PASS.), over and level on to the frame as shown in ILLUSTRATION 5.
  10. Install the 1/2" X 6 1/2" top shock bolt through the upper hoop shock mounts and the center brace support as shown in ILLUSTRATION 6.
  11. Inspect the inside of the frame for fuel lines, brake lines and wires. If clear drill the center brace support hole through the frame as shown in ILLUSTRATION 5.
  12. Remove the top shock bolt as shown in ILLUSTRATION 6.
  13. Install the shocks to the upper shock hoop mount as shown in ILLUSTRATION 6.
  14. Install the shocks to the lower shock hoop mount as shown in ILLUSTRATION 7. Make sure 90-1442 spacers are between the lower mount and the shock.
  15. **With the suspension hanging the shocks should install. If you must compress the suspension to install the lower shock bolt DO NOT proceed with the installation. Longer shocks are required please call.**
  16. Tighten the center brace support with the 1/2" X 4 1/2" bolt to 60 Ft. Lbs. as shown in ILLUSTRATION 6.
  17. Torque the shock mount nuts to 55

Ft. Lbs.

18. Torque the 9/16" hardware to 75 Ft. Lbs.
19. Repeat on the other side of the vehicle.
20. Install the wheel on the vehicle and torque the lug nuts to the factory specifications.

21. Recheck brake/steering systems. Be sure all hoses are long enough. Make sure there are no clearance problems.
22. Using the brake line kit 90-6029 position brake lines so they do not make contact with any moving parts. Hoses must be able to slide

ILLUSTRATION 5a

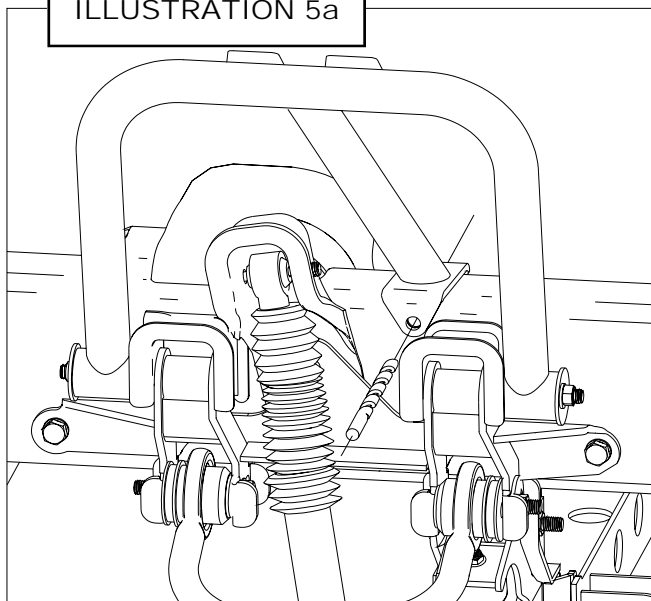

ILLUSTRATION 5b

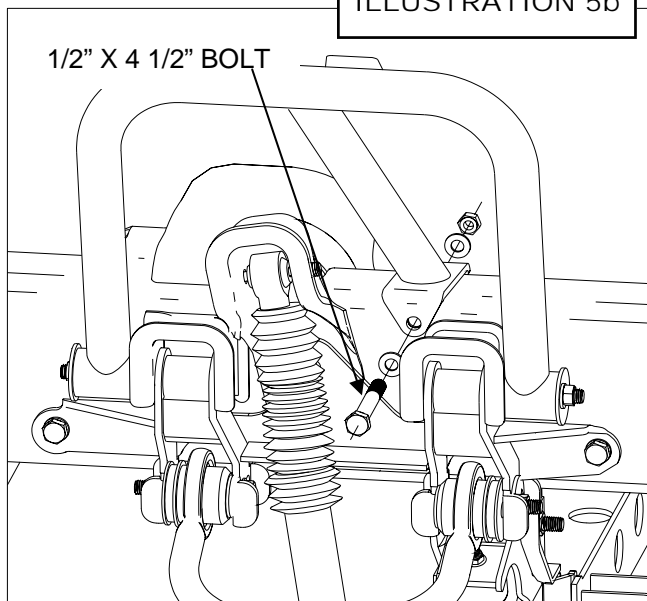

ILLUSTRATION 6

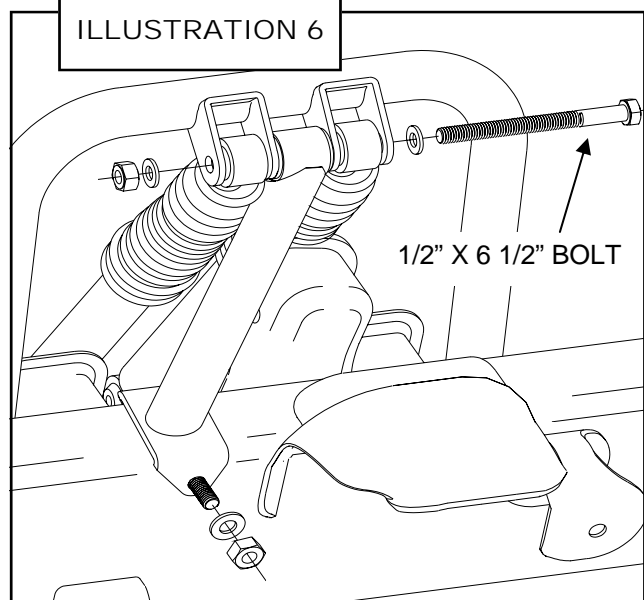
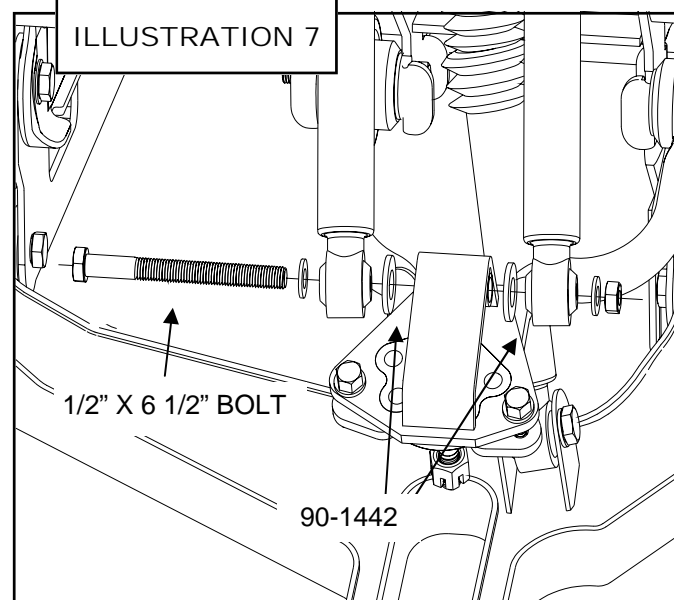

ILLUSTRATION 7



unrestricted through the grommets provided.

23. Recheck for proper installation and torque all newly installed hardware.

24. After 100 miles recheck for proper torque on all newly installed hardware.

25. Recheck all hardware for tightness after off road use.

Use this only as a guide for hardware without a called out torque specification in the instruction manual.

<b>Bolt Torque and ID</b>						
<b>Decimal System</b>			<b>Metric System</b>			
All Torques in Ft. Lbs. Maximums						
Bolt Size	Grade 5	Grade 8	Bolt Size	Class 9.8	Class 10.9	Class 12.9
5/16	15	20	M6	5	9	12
3/8	30	45	M8	18	23	27
7/16	45	60	M10	32	45	50
1/2	65	90	M12	55	75	90
9/16	95	130	M14	85	120	145
5/8	135	175	M16	130	165	210
3/4	185	280	M18	170	240	290

<p>1/2-13x1.75 HHCS</p> <p>Grade 5    Grade 8</p> <p>(No. of Marks + 2)</p> <p>D    T    L    X</p>	<p>M12-1.25x50 HHCS</p> <p>D    T    L    X</p>
<p>G = Grade (Bolt Strength)</p> <p>D = Nominal Diameter (Inches)</p> <p>T = Thread Count (Threads per Inch)</p> <p>L = Length (Inches)</p> <p>X = Description (Hex Head Cap Screw)</p>	<p>P = Property Class (Bolt Strength)</p> <p>D = Nominal Diameter (Millimeters)</p> <p>T = Thread Pitch (Thread Width, mm)</p> <p>L = Length (Millimeters)</p> <p>X = Description (Hex Head Cap Screw)</p>

**Notice to Owner operator, Dealer and Installer:**

Vehicles that have been enhanced for off-road performance often have unique handling characteristics due to the higher center of gravity and larger tires. This vehicle may handle, react and stop differently than many passenger cars or unmodified vehicles, both on and off-road. You must drive your vehicle safely! Extreme care should always be taken to prevent vehicle rollover or loss of control, which can result in serious injury or even death. Always avoid sudden sharp turns or abrupt maneuvers and allow more time and distance for braking! Pro Comp reminds you to fasten your seat belts at all times and reduce speed! We will gladly answer any questions concerning the design, function, maintenance and correct use of our products.

**Please make sure your Dealer/Installer explains and delivers all warning notices, warranty forms and instruction sheets included with Pro Comp product.**

Application listings in this catalog have been carefully fit checked for each model and year denoted. However, Pro Comp reserves the right to update as necessary, without notice, and will not be held responsible for misprints, changes or variations made by vehicle manufacturers. Please call when in question regarding new model year, vehicles not listed by specific body or chassis styles or vehicles not originally distributed in the USA.

**Please note that certain mechanical aspects of any suspension lift product may accelerate ordinary wear of original equipment components.** Further, installation of certain Pro Comp products may void the vehicle's factory warranty as it pertains to certain covered parts; it is the consumer's responsibility to check with their local dealer for warranty coverage before installation of the lift.

**Warranty and Return policy:**

Pro Comp warrants its full line of products to be free from defects in workmanship and materials. Pro Comp's obligation under this warranty is limited to repair or replacement, at Pro Comp's option, of the defective product. Any and all costs of removal, installation, freight or incidental or consequential damages are expressly excluded from this warranty. Pro Comp is not responsible for damages and / or warranty of other vehicle parts related or non-related to the installation of Pro Comp product. A consumer who makes the decision to modify his vehicle with aftermarket components of any kind will assume all risk and responsibility for potential damages incurred as a result of their chosen modifications. Warranty coverage does not include consumer opinions regarding ride comfort, fitment and design. Warranty claims can be made directly with Pro Comp or at any factory authorized Pro Comp dealer.

**IMPORTANT!** To validate the warranty on this purchase please be sure to mail in the warranty card.

**Claims not covered under warranty-**

- Parts subject to normal wear, this includes bushings, bump stops, ball joints, tie rod ends and heim joints
  - Discontinued products at Pro Comp's discretion
- Bent or dented product
- Finish after 90 days
- Leaf or coil springs used without proper bump stops
- Light bulbs
- Products with evident damage caused by abrasion or contact with other items
- Damage caused as a result of not following recommendations or requirements called out in the installation manuals
- Products used in applications other than listed in Pro Comp's catalog
- Components or accessories used in conjunction with other manufacturer's systems
- Tire & Wheel Warranty as per Pro Competition Tire Company policy
- Warranty claims without "Proof of Purchase"
- Pro Comp Pro Runner coil over shocks are considered a serviceable shock with a one-year warranty against leakage only. Rebuild service and replacement parts will be available and sold separately by Pro Comp. Contact Pro Comp for specific service charges.
- Pro Comp accepts no responsibility for any altered product, improper installation, lack of or improper maintenance, or improper use of our products.

E-Mail: [tech@explorerprocomp.com](mailto:tech@explorerprocomp.com)  
Website: [www.explorerprocomp.com](http://www.explorerprocomp.com)  
Fax: (619) 216-1474  
Ph: (619) 216-1444

<u>PLACE</u>
<u>WARRANTY REGISTRATION</u>
<u>NUMBER</u>
HERE: _____