

2360 Boswell Road
Chula Vista, CA 91914
Phone 619.216.1444
Fax 619.216.1474
E-Mail tech@explorerprocomp.com



PRO COMP SUSPENSION

Suspension Systems that Work!

Important! This kit does not fit Vehicles with 46RE transmissions

**PART# 56701
1994-2005
DODGE 1500
4WD INDEX
RING KIT**

BEFORE YOU START:

MUST BE PURCHASED SEPERATELY:

Rear transmission seal (Part# 1-05019020AA or Part# 1-05019020AB) can be purchased from your local Dodge dealer.

This document contains very important information that includes warranty information and instructions for resolving problems you may encounter. Please keep it in the vehicle as a permanent record.

Part #	Description	Qty.	Illus.	Page
90-4125	TRANSFER CASE INDEX RING	1	1	4
90-4126	TRANSMISSION SEAL ADAPTER	1	2	5
90-4127	DODGE DRIVESHAFT SPACER	1	2	5
90-6407	HARDWARE PACK: Index Ring	1	1	4
70-0371501806	3/8" x 1 1/2" Countersunk Allen Head Bolt	6	1	4
90-6408	HARDWARE PACK: Driveshaft Spacer	1	4	6
71-120601751000	12mm X 1.75 X 60mm 10.9 hex Bolt	4	4	6
73-01208840	12mm Flat Washers	4	4	6

MUST BE PURCHASED SEPERATELY:

Rear transmission seal (Part# 1-05019020AA or Part# 1-05019020AB) can be purchased from your local Dodge dealer.

NOTE: THIS KIT DESIGNED FOR USE WITH FACTORY DODGE DRIVESHAFT, ANY OTHER DRIVESHAFT IS NOT RECOMMENDED. CALL THE PRO COMP TECH DEPARTMENT WITH ANY QUESTIONS.

Optional Equipment Available from your Pro Comp Distributor!

Skid Plate

PN 56102

Hoop Style Light Bar

PN 26100 (Black), 26100G (Grey)

Also, check out our outstanding selection of Pro Comp tires
compliment your new installation!

Introduction:

- ◆ This installation requires a professional mechanic!
- ◆ We recommend that you have access to a factory service manual for your vehicle to assist in the disassembly and reassembly of your vehicle. It contains a wealth of detailed information.
- ◆ Prior to installation, carefully inspect the vehicle's steering and driveline systems paying close attention to the tie rod ends, ball joints, wheel bearing preload, pitman and idler arm. Additionally, check steering-to-frame and suspension-to-frame attaching points for stress cracks. The overall vehicle must be in excellent working condition. Repair or replace all worn or damaged parts!
- ◆ Read the instructions carefully and study the illustrations before attempting installation! You may save yourself a lot of extra work.
- ◆ Check the parts and hardware against the parts list to assure that your kit is complete. Separating parts according to the areas where they will be used and placing the hardware with the brackets before you begin will save installation time.
- ◆ Check the special equipment list and ensure the availability of these tools.
- ◆ Secure and properly block vehicle prior to beginning installation.
- ◆ ALWAYS wear safety glasses when using power tools or working under the vehicle!
- ◆ Use caution when cutting is required under the vehicle. The factory undercoating is flammable. Take appropriate precautions. Have a fire extinguisher close at hand.
- ◆ Foot pound torque readings are listed on the Torque Specifications chart at the end of the instructions. These are to be used unless specifically directed otherwise. Apply thread lock retaining compound where specified.
- ◆ **Please note that while every effort is made to ensure that the installation of your Pro Comp lift kit is a positive experience, variations in construction and assembly in the vehicle manufacturing process will virtually ensure that some parts may seem difficult to install. Additionally, the current trend in manufacturing of vehicles results in a frame that is highly flexible and may shift slightly on disassembly prior to installation. The use of pry bars and tapered punches for alignment is considered normal and usually does not indicate a faulty product. However, if you are uncertain about some aspect of the installation process, please feel free to call our tech support department at the number listed on the cover page. We do not recommend that you modify the Pro Comp parts in any way as this will void any warranty expressed or implied by the Pro Comp Suspension company.**

INSTALLATION INSTRUCTIONS:

1. Ensure that your work space is of adequate size and the work surface is level. Place the vehicle in park. Place your floor jack under the front cross member and raise vehicle. Place jack stands under the frame rails behind the front wheel wells and lower the frame onto the stands. Remove the jack and place the vehicle back in gear, set the emergency brake, and place blocks both in front of and behind the rear wheels.
2. Mark the front and rear driveshafts with an index mark to ensure that they are reinstalled in the same position. Remove the driveshafts from the vehicle.
3. Disconnect the 4 (2 per side) oxygen sensors. Unbolt the exhaust pipes from the manifolds and slide the exhaust back.

NOTE: Spraying the rubber mounts with lubricant will aid in sliding the exhaust back out of the way.

4. Drain fluid from the transfer case. Remove the speedometer wire from the rear of the case. Remove the transfer case shift linkage from the transfer case

bracket if applicable. Raise the transmission with a transmission or floor jack and remove the transmission mount to access the (2) lower transfer case bolts.

NOTE: With the transmission mount out of the vehicle you will need to clearance the top rear lip of the mount in order to accommodate the new index ring. See ILLUSTRATION 2.

5. Remove the six OE retaining nuts that hold the transfer case to the transmission.
6. Support the transfer case with a transmission or floor jack and remove it from the vehicle.
7. With the transfer case on a bench remove the six studs from the case. Save the OE nuts for reuse.

NOTE: Now would be a good time to check the condition of the input seal and extension housing seal. Replace them if necessary.

8. Clean the outside edge of the transfer case being sure to remove all silicone. Make sure the surface is clear of any residue.

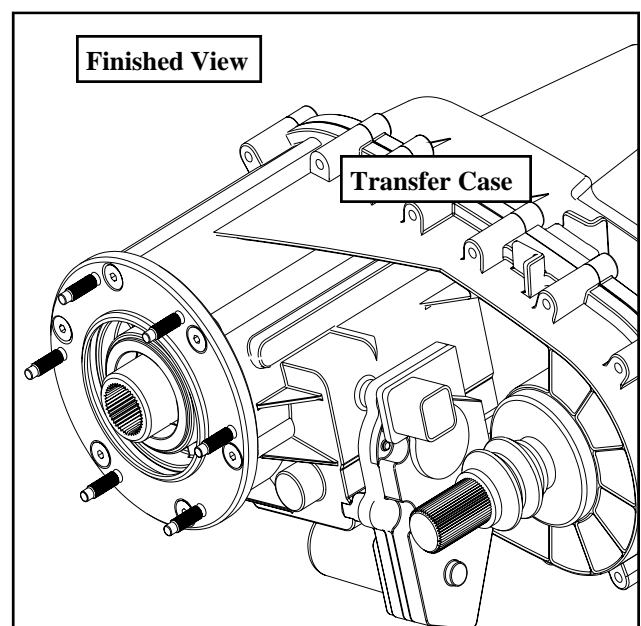
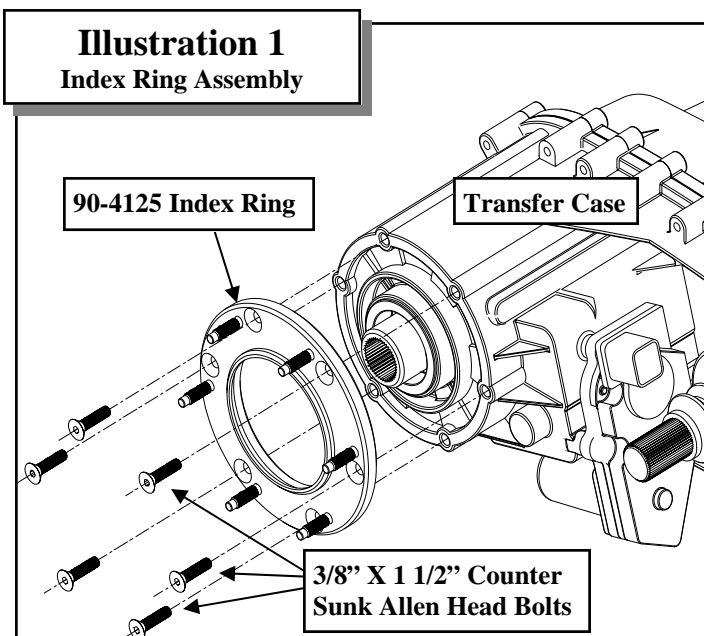

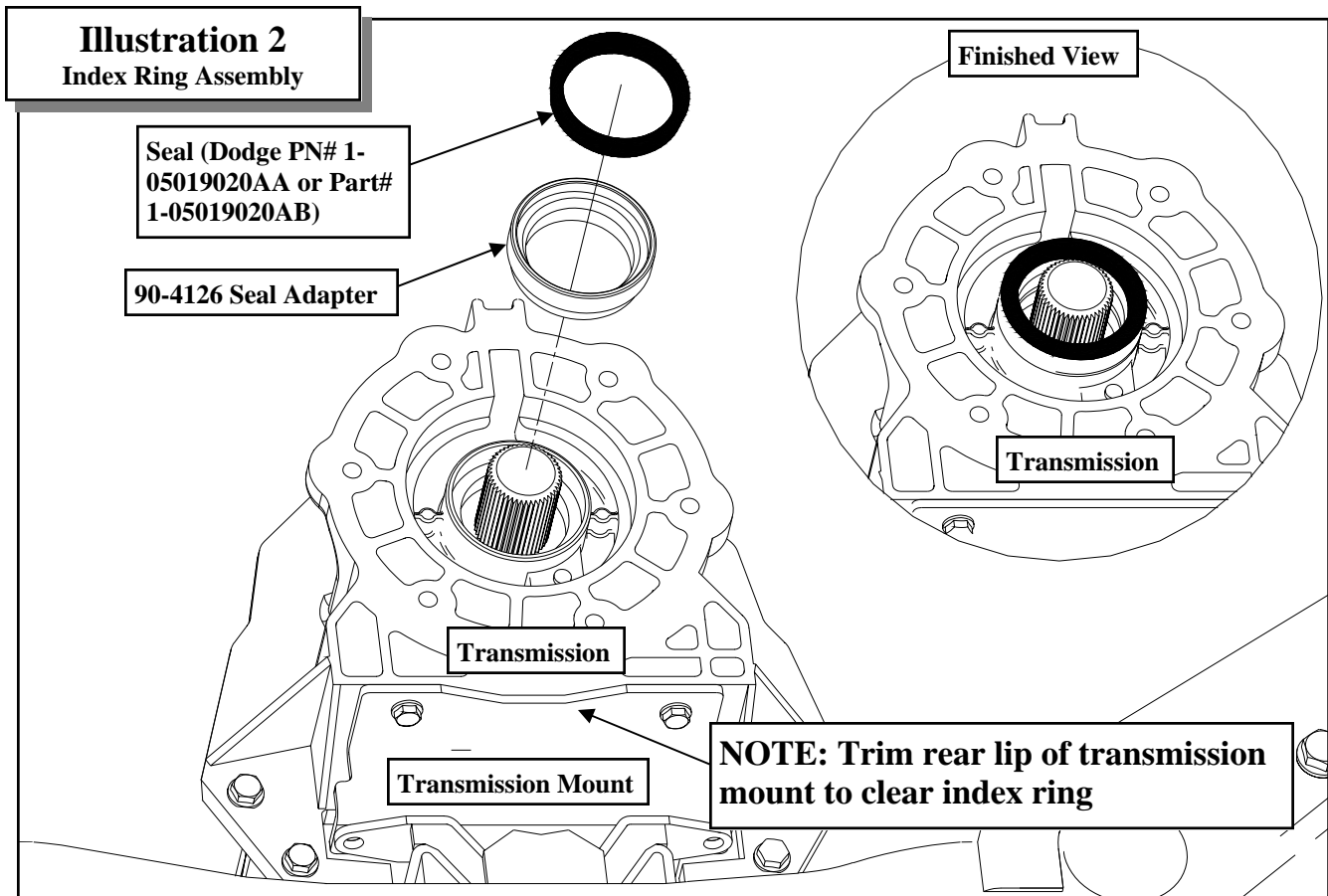

9. Line up index ring (90-4125) on transfer the case. The ring will only install one way. With a marker, when all the holes are aligned properly, mark the position of the ring on the transfer case for proper alignment after the silicone is applied.
10. Run a bead of silicone along the mounting face on the transfer case. Be sure not to get any silicone in the bolt holes. Line up the previously marked index lines and install the index ring (90-4125) to the transfer case using the supplied 3/8" X 1 1/2" counter sunk Allen bolts. Torque to 35 ft./lbs. See ILLUSTRATION 1.

NOTE: Be sure to tighten the index ring evenly all the way around.

11. Using the proper tool carefully remove the inner transmission seal located at the rear of the transmission.
12. Carefully install the supplied seal adapter (90-4126) into the rear of the transmis-

sion. It is recommended that a thin layer of silicone is applied on the outside of the adapter so it will slide in with no binding. Using the proper tool install the adapter so it seated is flush with the transmission. See ILLUSTRATION 2.

13. Using the proper tool install the new seal (Dodge part # 1-05019020AA or Part# 1-05019020AB) so it is flush in the adapter. See ILLUSTRATION 2.
14. Clean the backside of the transmission mounting surface and run a bead of silicone around the rear outer edge of the transmission mounting surface.

IMPORTANT!: Before tightening down the transfer case into place be sure install the front driveshaft into the transfer case. See ILLUSTRATION 3. You will not be able to install it after the transfer case is fully installed.

15. Reinstall the transfer case using a trans-

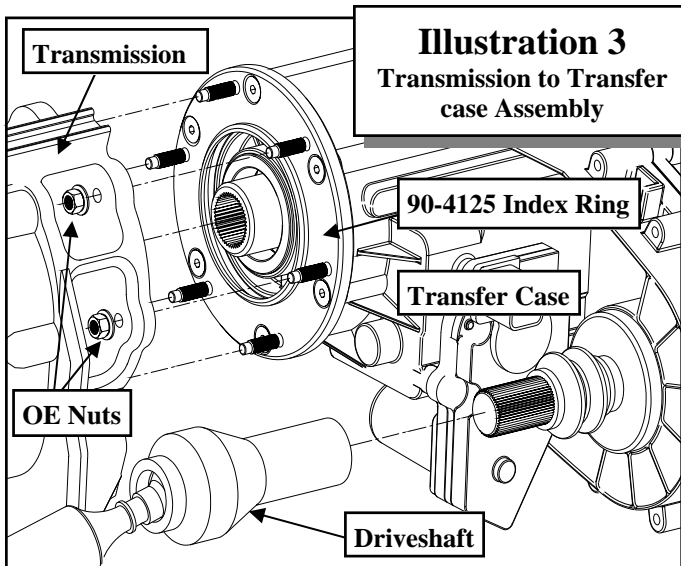

Illustration 3
Transmission to Transfer
case Assembly

mission or floor jack. Secure the transfer case to the transmission using the **OE** nuts. Torque the **OE** nuts using a circular pattern in two stages, stage one to 17 ft./lbs. and the second stage to 35 ft./lbs. See ILLUSTRATION 3.

16. Secure front driveshaft to the front axle using the supplied **12mm X 1.75 X 60mm** bolts and driveshaft spacer (**90-4127**), with the raised flange facing toward the rear of the vehicle, on the axle end of driveshaft. Be sure line up previ-

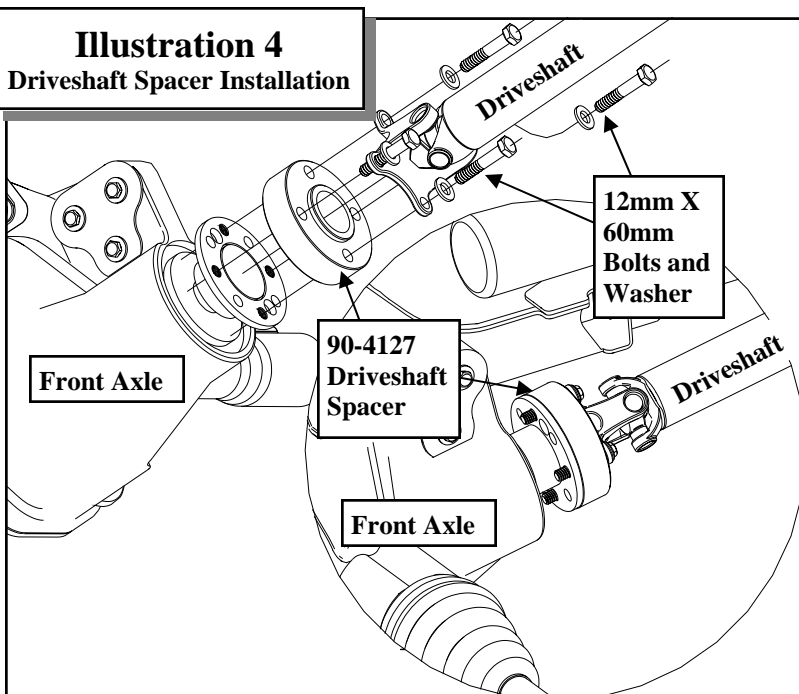

Illustration 4
Driveshaft Spacer Installation

ously applied index marks before tightening bolts. Use thread locker on the bolts. Torque to 75 ft./lbs. See ILLUSTRATION 4.

17. Lower transmission and reinstall the mount with the trimmed upper lip facing toward the rear of the vehicle.
18. Line up the previously applied index marks and reinstall the rear driveshaft. Use thread locker on the bolts. Torque bolts to manufacturers specifications.
19. Reconnect all vent hoses, vacuum lines, and shift linkage. Be sure to reconnect all lines exactly as they came from the factory. There must be no pinching, rubbing, or stretching of any of these components.
20. Refill the transfer case with fluid. See factory manual for instructions.
21. Slide the exhaust back forward and bolt it back up to the manifolds. Torque exhaust bolts to factory specifications. Reconnect the oxygen sensor wiring harnesses.
22. Lower vehicle back to the ground.

NOTES:

- ⇒ After 100 miles recheck for proper torque on all newly installed hardware.
- ⇒ Recheck all hardware for tightness after off road use.

Use this only as a guide for hardware without a called out torque specification in the instruction manual.

Bolt Torque and ID						
Decimal System			Metric System			
All Torques in Ft. Lbs. Maximums						
Bolt Size	Grade 5	Grade 8	Bolt Size	Class 9.8	Class 10.9	Class 12.9
5/16	15	20	M6	5	9	12
3/8	30	45	M8	18	23	27
7/16	45	60	M10	32	45	50
1/2	65	90	M12	55	75	90
9/16	95	130	M14	85	120	145
5/8	135	175	M16	130	165	210
3/4	185	280	M18	170	240	290

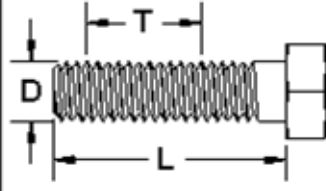
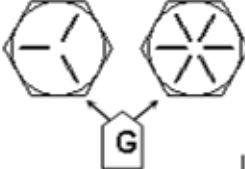
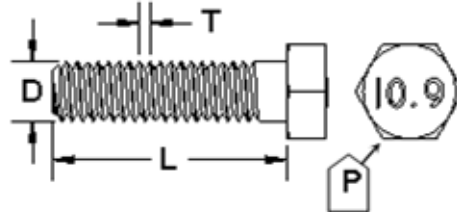
		
1/2-13x1.75 HHCS D T L X	Grade 5 Grade 8 (No. of Marks + 2)	M12-1.25x50 HHCS D T L X

G = Grade (Bolt Strength) D = Nominal Diameter (Inches) T = Thread Count (Threads per Inch) L = Length (Inches) X = Description (Hex Head Cap Screw)	P = Property Class (Bolt Strength) D = Nominal Diameter (Millimeters) T = Thread Pitch (Thread Width, mm) L = Length (Millimeters) X = Description (Hex Head Cap Screw)
--	---

Notice to Owner operator, Dealer and Installer:

Vehicles that have been enhanced for off-road performance often have unique handling characteristics due to the higher center of gravity and larger tires. This vehicle may handle, react and stop differently than many passenger cars or unmodified vehicles, both on and off-road. You must drive your vehicle safely! Extreme care should always be taken to prevent vehicle rollover or loss of control, which can result in serious injury or even death. Always avoid sudden sharp turns or abrupt maneuvers and allow more time and distance for braking! Pro Comp reminds you to fasten your seat belts at all times and reduce speed! We will gladly answer any questions concerning the design, function, maintenance and correct use of our products.

Please make sure your Dealer/Installer explains and delivers all warning notices, warranty forms and instruction sheets included with Pro Comp product.

Application listings in this catalog have been carefully fit checked for each model and year denoted. However, Pro Comp reserves the right to update as necessary, without notice, and will not be held responsible for misprints, changes or variations made by vehicle manufacturers. Please call when in question regarding new model year, vehicles not listed by specific body or chassis styles or vehicles not originally distributed in the USA.

Please note that certain mechanical aspects of any suspension lift product may accelerate ordinary wear of original equipment components. Further, installation of certain Pro Comp products may void the vehicle's factory warranty as it pertains to certain covered parts; it is the consumer's responsibility to check with their local dealer for warranty coverage before installation of the lift.

Warranty and Return policy:

Pro Comp warrants its full line of products to be free from defects in workmanship and materials. Pro Comp's obligation under this warranty is limited to repair or replacement, at Pro Comp's option, of the defective product. Any and all costs of removal, installation, freight or incidental or consequential damages are expressly excluded from this warranty. Pro Comp is not responsible for damages and / or warranty of other vehicle parts related or non-related to the installation of Pro Comp product. A consumer who makes the decision to modify his vehicle with aftermarket components of any kind will assume all risk and responsibility for potential damages incurred as a result of their chosen modifications. Warranty coverage does not include consumer opinions regarding ride comfort, fitment and design. Warranty claims can be made directly with Pro Comp or at any factory authorized Pro Comp dealer.

IMPORTANT! To validate the warranty on this purchase please be sure to mail in the warranty card.

Claims not covered under warranty-

- Parts subject to normal wear, this includes bushings, bump stops, ball joints, tie rod ends and heim joints
 - Discontinued products at Pro Comp's discretion
- Bent or dented product
- Finish after 90 days
- Leaf or coil springs used without proper bump stops
- Light bulbs
- Products with evident damage caused by abrasion or contact with other items
- Damage caused as a result of not following recommendations or requirements called out in the installation manuals
- Products used in applications other than listed in Pro Comp's catalog
- Components or accessories used in conjunction with other manufacturer's systems
- Tire & Wheel Warranty as per Pro Competition Tire Company policy
- Warranty claims without "Proof of Purchase"
- Pro Comp Pro Runner coil over shocks are considered a serviceable shock with a one-year warranty against leakage only. Rebuild service and replacement parts will be available and sold separately by Pro Comp. Contact Pro Comp for specific service charges.
- Pro Comp accepts no responsibility for any altered product, improper installation, lack of or improper maintenance, or improper use of our products.

E-Mail: tech@explorerprocomp.com
Website: www.explorerprocomp.com
Fax: (619) 216-1474
Ph: (619) 216-1444

PLACE WARRANTY REGISTRATION NUMBER HERE: _____
