

2360 Boswell Road  
Chula Vista, CA 91914  
Phone 619.216.1444  
Fax 619.216.1474  
E-Mail tech@explorerprocomp.com



## PRO COMP SUSPENSION

---

Suspension Systems that Work!

**Part # 51086/51086MX  
2005-2006 2WD Silverado  
with Torsion Bars  
6 Inch Lift Kit**

This document contains very important information that includes warranty information and instructions for resolving problems you may encounter. Please keep it in the vehicle as a permanent record.

Box 1 of 5-PN 51086/51086MX-1

Part #	Description	Qty.	Illus.	Page
90-1435	COMPRESSION STRUT MOUNTS	2	9	11
90-1761	FRONT CROSS MEMBER	1	3	7
90-2144	BUMP STOP SPACER	2	14	14
90-6227	<b>HARDWARE PACK: Crossmember</b>	1	-	-
70-0625001800	5/8" X 5" GR 8 HEX BOLT	2	6	9
70-0625501800	5/8" X 5 1/2" GR 8 HEX BOLT	2	6	9
72-062100816	5/8" USS GR 8 STOVER NUT	4	6	9
73-06200034	5/8" SAE GR 8 FLAT WASHERS	8	6	9
90-6262	<b>HARDWARE PACK: Crossmember Braces</b>	1	-	-
70-0621501500	5/8" X 1 1/2" GR 5 HEX BOLT	2	3	7
72-062100512	5/8" USS GR 5 NYLOCK NUT	2	3	7
73-06200034	5/8" SAE GR 8 FLAT WASHERS	4	3	7
72-056100512	9/16" USS GR 5 NYLOCK NUT	2	3	7
73-05600034	9/16" SAE GR 8 FLAT WASHER	2	3	7
90-6263	<b>HARDWARE PACK: Bushings and Sleeves</b>	1	-	-
15-11148	COMPRESSION STRUT BUSHING	8	9	11
90-2109	SLEEVE, COMPRESSION STRUT - 2.75"	4	9	11
90-6264	<b>HARDWARE PACK: low Profile Bump Stop</b>	1	-	-
15-11018	LOW-PROFILE BUMPSTOP	2	4	7
72-037100512	3/8" GR 5 NYLOCK NUT	2	4	7
73-03700530	3/8" GR 5 FLAT WASHER	2	4	7
90-6427	<b>HARDWARE PACK: Sway Bar</b>	1	-	-
90-1476	NUT PLATE	2	9	11
13-90420	3/8" X 14 1/2" STUD	2	8	10
72-037200510	3/8" HEX NUT	4	8	10
90-2329	SPACER, .625" X .120" WALL, 9 1/2"	2	8	10
P-438	STEM CUSHION PACK	4	8	10
90-6177	<b>HARDWARE PACK: Torsion Drop Bushings</b>	1	-	-
90-2011	SPACER, 1" X .05" X 1 1/2"	2	12	12
15-11149	BUSHING, URETHANE	4	12	12
90-6181	<b>HARDWARE PACK: Shock Adapter</b>	1	-	-
90-1079	SHOCK ADAPTER	2	-	-
70-0502751500	1/2" X 2 3/4" GR 5 HEX BOLT	2	-	-
72-05000100512	1/2" USS GR 5 NYLOCK NUT	2	-	-
72-06200100512	5/8" USS GR 5 NYLOCK NUT	2	-	-
73-06200032	5/8" USS BR 5 FLAT WASHER	2	-	-
54314	SHOCK SLEEVE, 1/2" X 5/8" X 1"	2	-	-

Box 2 of 5-PN 51086/51086MX-2

90-4118	SPINDLE, DRIVER SIDE	1	-	-
90-4119	SPINDLE, PASSENGER SIDE	1	-	-
90-6411	<b>HARDWARE PACK: Not Used</b>	1	-	-
90-1078	CAM BOLT GUIDE: NOT USED	2	-	-

Box 3 of 5-PN 51086MX/51086MX-3

90-1635	TORSION DROP BRACKET: Universal	2	10	12
90-1638	TORSION DROP ADAPTER	2	11	12
90-1740	REAR CROSS MEMBER	1	3	7
90-2126	COMPRESSION STRUTS	2	9	11
90-2333	CROSS MEMBER BRACE: Driver	1	3	7
90-2334	CROSS MEMBER BRACE: Passenger	1	3	7
90-6223	<b>HARDWARE PACK: Torsion Bar Adapter</b>	1	-	-
70-0371251800	3/8" X 1 1/4" GR 8 HEX BOLT	4	12	12

Part #	Description	Qty.	Illus.	Page
72-03700100816	3/8" NC SELF LOCKING NUT	4	12	12
73-03700034	3/8" SAE GR 8 FLAT WASHER	8	12	12
<b>90-6234</b>	<b>HARDWARE PACK: Compression Strut</b>	<b>1</b>	<b>-</b>	<b>-</b>
70-0501251800	1/2" X 1 1/4" GR 8 HEX BOLT	2	9	12
70-0504001800	1/2" X 4" GR 8 HEX BOLT	4	9	12
72-050100816	1/2" GR 8 STOVER NUT	4	9	12
73-05000034	1/2" GR 8 FLAT WASHER	10	9	12
<b>90-6250</b>	<b>HARDWARE PACK: Torsion Drop Mount/Bump Stop</b>	<b>1</b>	<b>-</b>	<b>-</b>
70-0431251800	7/16" X 1 1/4" GR 8 HEX BOLT	8	10	12
72-043100816	7/16" USS GR 8 STOVER NUT	8	10	12
73-04300034	7/16" SAE GR 8 FLAT WASHER	16	10	12
70-0371251800	3/8" X 1 1/4" GR 8 HEX BOLT	2	14	14
72-037100816	3/8" USS GR 8 STOVER NUT	2	14	14
73-03700034	3/8" SAE GR 8 FLAT WASHER	4	14	14

Box 4 of 5-PN 51086-4

<b>920590</b>	<b>ES 9000 FRONT SHOCKS</b>	<b>2</b>	<b>2</b>	<b>6</b>
<b>927543</b>	<b>ES 9000 REAR SHOCKS</b>	<b>2</b>	<b>-</b>	<b>-</b>

Or Box 4 of 5-PN 51086MX-4

<b>MX6019</b>	<b>MX-6 FRONT SHOCKS</b>	<b>2</b>	<b>2</b>	<b>6</b>
<b>MX6098</b>	<b>MX-6 REAR SHOCKS</b>	<b>2</b>	<b>-</b>	<b>-</b>

Box 5 of 5-PN 51086/51086MX-5

<b>13-90087</b>	<b>U-BOLTS</b>	<b>4</b>	<b>13</b>	<b>13</b>
<b>20-65302</b>	<b>HARDWARE PACK: U-bolts</b>	<b>1</b>	<b>-</b>	<b>-</b>
<b>95-550</b>	<b>LIFT BLOCK</b>	<b>2</b>	<b>13</b>	<b>13</b>

### **Warning!**

***Be extremely careful when unloading or loading the torsion bars on your vehicle. There is a tremendous amount of stored energy! Keep your hands and body clear of the adjuster arm assembly and puller tool in case anything slips or breaks!***

### **Special Equipment**

- ⇒ A special removal tool is required for safe removal and installation of the torsion adjuster arms. This special puller can be purchased from your local GM dealer (Tool #J36202) or from the Kent Moore Tool Group in Roseville, MI. (800) 345-2233 or (313) 774-9500 (Part #J22517-C). You may be able to rent these at your local parts store. Please refer to your GM service manual for more information.
- ⇒ A welding machine and someone with welding experience is required for a small portion of this installation.

**Optional Equipment Available from your PRO COMP Distributor!**

**TRACTION BARS: PN 71000, MOUNTING KIT 71199**

**ALSO, CHECK OUT OUR OUTSTANDING SELECTION OF PRO COMP TIRES TO COMPLIMENT YOUR NEW INSTALLATION!**

## Introduction:

- ◆ **This installation requires a professional mechanic!**
- ◆ We recommend that you have access to a GM service manual for your vehicle to assist in the disassembly and reassembly of your vehicle. It contains a wealth of detailed information.
- ◆ Prior to installation, carefully inspect the vehicle's steering and driveline systems paying close attention to the tie rod ends, ball joints, wheel bearing preload, pitman and idler arm. Additionally, check steering-to-frame and suspension-to-frame attaching points for stress cracks. The overall vehicle must be in excellent working condition. Repair or replace all worn or damaged parts!
- ◆ Read the instructions carefully and study the illustrations before attempting installation! You may save yourself a lot of extra work.
- ◆ Check the parts and hardware against the parts list to assure that your kit is complete. Separating parts according to the areas where they will be used and placing the hardware with the brackets before you begin will save installation time.
- ◆ Check the special equipment list and ensure the availability of these tools.
- ◆ Secure and properly block vehicle prior to beginning installation.
- ◆ **ALWAYS** wear safety glasses when using power tools or working under the vehicle!
- ◆ Use caution when cutting is required under the vehicle. The factory undercoating is flammable. Take appropriate precautions. Have a fire extinguisher close at hand.
- ◆ Foot pound torque readings are listed on the Torque Specifications chart at the end of the instructions. These are to be used unless specifically directed otherwise. Apply Loctite® retaining compound where specified.
- ◆ *Please note that while every effort is made to ensure that the installation of your Pro Comp lift kit is a positive experience, variations in construction and assembly in the vehicle manufacturing process will virtually ensure that some parts may seem difficult to install. Additionally, the current trend in manufacturing of vehicles results in a frame that is highly flexible and may shift slightly on disassembly prior to installation. The use of pry bars and tapered punches for alignment is considered normal and usually does not indicate a faulty product. However, if you are uncertain about some aspect of the installation process, please feel free to call our tech support department at the number listed on the cover page. We do not recommend that you modify the Pro Comp parts in any way as this will void any warranty expressed or implied by the Pro Comp Suspension company.*

## Please Note:

- ⇒ Front end and head light realignment is necessary!
- ⇒ Speedometer and ABS recalibration will be necessary if larger tires (10% more than stock diameter) are installed
- ⇒ Due to differences in manufacturing, dimensions and inflated measurements, tire and wheel combinations should be test fit prior to installation. Tire and wheel choice is crucial in assuring proper fit, performance, and the safety of your Pro Comp equipped vehicle. For this application, we recommend a wheel not to exceed 8" in width with a minimum backspacing of 4" must be used, additionally, a quality tire of radial design, not exceeding 35" tall X 12.5" wide is also recommended. Please note that the use of a 35" X 12.5" tire may require fender modification. Violation of these recommendations will not be endorsed as acceptable by Pro Comp Suspension and will void any and all warranties either written or implied.

## FRONT INSTALLATION

1. Ensure that your work space is of adequate size and the work surface is level. Place the vehicle in neutral. Place your floor jack under the front cross member and raise vehicle. Place jack stands under the frame rails behind the front wheel wells and lower the frame onto the stands. Remove the jack and place the vehicle back in gear, set the emergency brake, and place blocks both in front and behind the rear wheels.

2. Measure and record the distance from the center of each wheel to the top of its fender opening.

LF: \_\_\_\_\_ RF: \_\_\_\_\_

LR: \_\_\_\_\_ RR: \_\_\_\_\_

3. Remove any skid plates or debris shields from the vehicle.
4. Measure the torsion bar adjusting screw depth and record this dimension for later use on reassembly. See **Illustration 1**.

LEFT: \_\_\_\_\_ RIGHT: \_\_\_\_\_

5. Mark orientation and remove the torsion bar adjusting screw. Apply a small amount of lubrication grease to the puller threads and the puller shaft-to-adjuster arm contact point. Load the puller and torsion adjuster arm until the adjuster nut can be removed from the cross member. Release the puller to unload the torsion bar. With the bar unloaded, slide it forward into the lower control arm until the adjuster arm falls free.

*Note: If the bar seems stuck, use a hammer and punch through the hole in the rear of the cross member to dislodge it.*

6. Repeat this procedure on the other side of the vehicle.
7. Remove the torsion bar cross member by unbolting it from the frame.

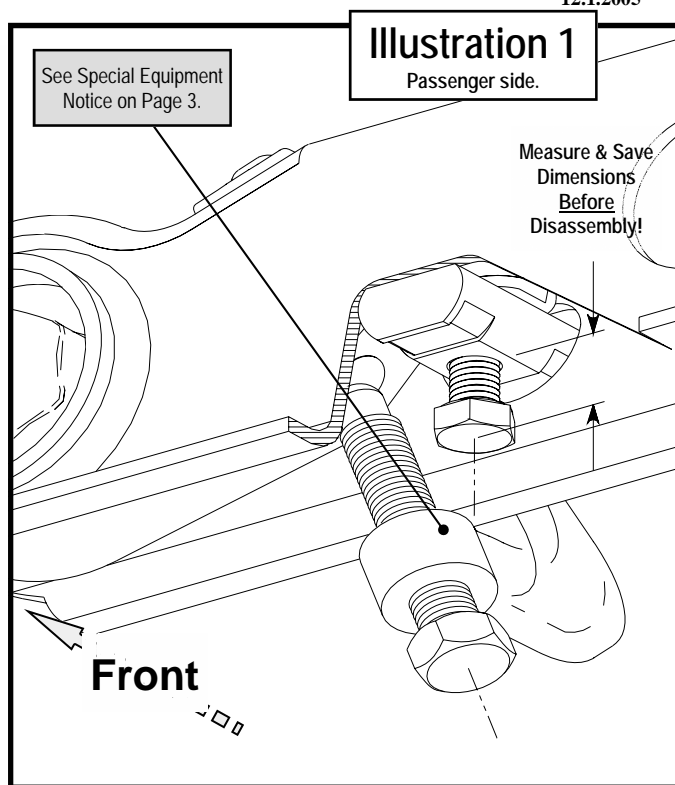

8. Remove the torsion bars from the lower A-arms.
9. Remove the front shock absorbers.
10. Remove the sway bar end links.
11. If you have a steering damper mounted, remove it from the vehicle.

---

### Work on one side of the vehicle at a time.

---

12. Remove the nut from the OE tie rod end. Using an appropriate removal tool, remove the tie rod end from the spindle.
13. Remove the brake calipers from the rotor and secure them clear of the work area. Secure calipers up with wire so they do not hang.  
**Caution: Do not suspend them by the brake lines! Damage will result!**
14. If your vehicle is equipped with ABS brakes, disconnect the wiring from the vehicle wire loom and any wiring clamps located on the frame.
15. Support the lower A-arm assembly with your

## Illustration 2

Driver side view

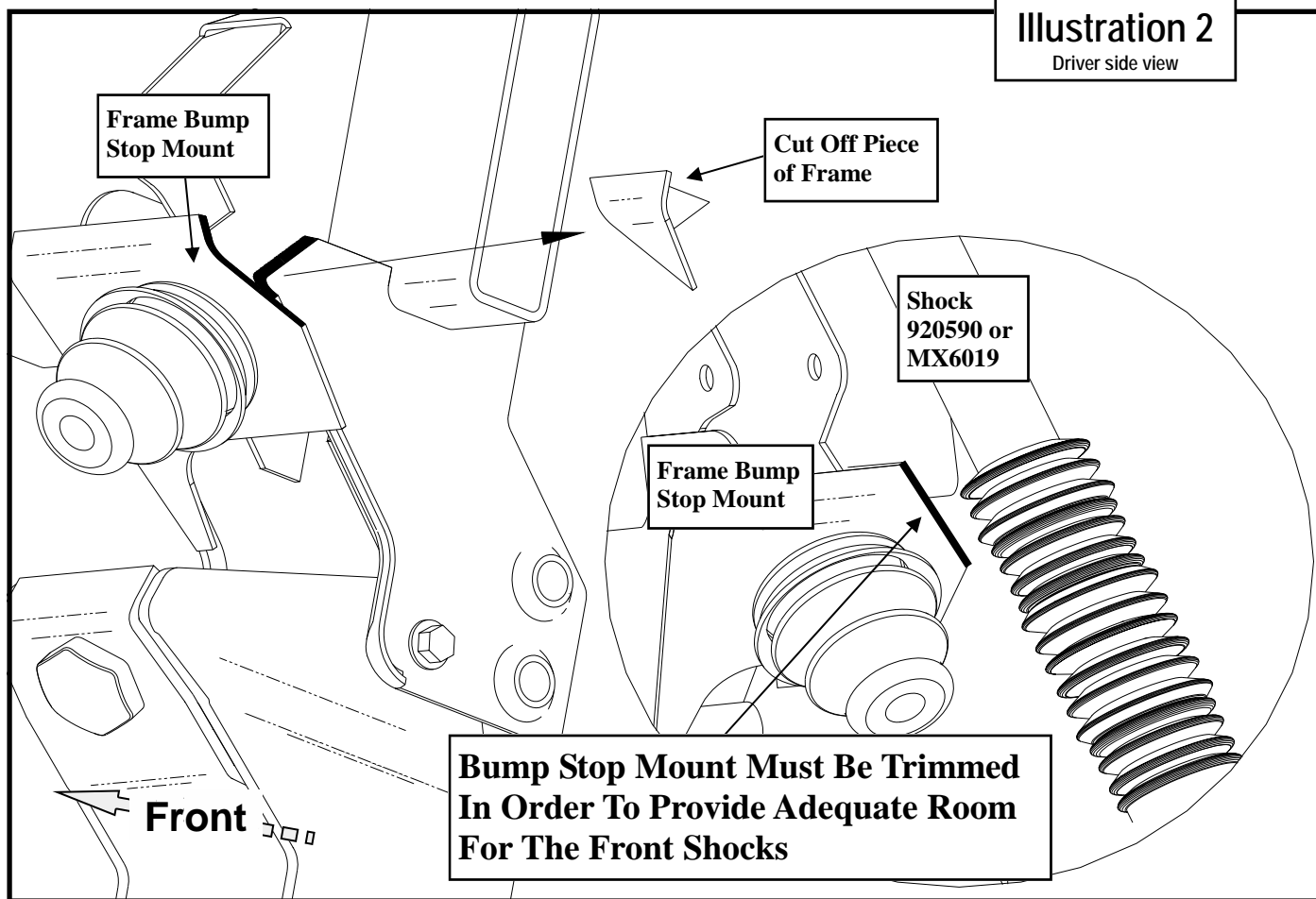

floor jack and remove the upper and lower ball joint bolts and again using the tools recommended in your GM service manual. Remove the spindle from the vehicle.

16. Support the lower A-arm assembly with your floor jack and remove the lower A-arm pivot bolts. Carefully remove the lower A-arms from the vehicle.

17. Using a suitable cutting tool, (abrasive cutoff wheel, Sawz-all, etc.) cut the rear top edge off the bump stop mounting surface as shown in **Illustration 2**. After cutting the frame, clean the area thoroughly and paint the exposed metal with a good quality paint.

**NOTE:** If this material is not removed then the frame will contact the front shocks.

---

**Repeat steps 12 thru 17 on the remaining side of the vehicle.**

---

18. Assemble the front cross member (PN 90-1761), rear cross member (PN 90-1740), and cross member braces (PN's 90-2333 & 90-2334) on your work bench. Use **Illustration 3** as a guide. Leave all these fasteners loose for the moment.

19. Install the urethane bump stops (PN 15-11018) from hardware pack 90-6264, onto the rear cross member as shown in **Illustration 4**.

20. Raise the crossmember assembly with your floor jack and fully seat it into the frame mount pockets. Torque the upper mount bolts to 107 ft. lbs. Torque the remaining fasteners in the assembly according to the torque chart on page 15. **DO NOT** torque the A-arm pivot bolts at this time. See **Illustration 5**.

21. Install the lower A-arms into the new drops using the 5/8" X 5" bolts in the front and the 5/8" X 5 1/2" bolts in the rear. This hardware

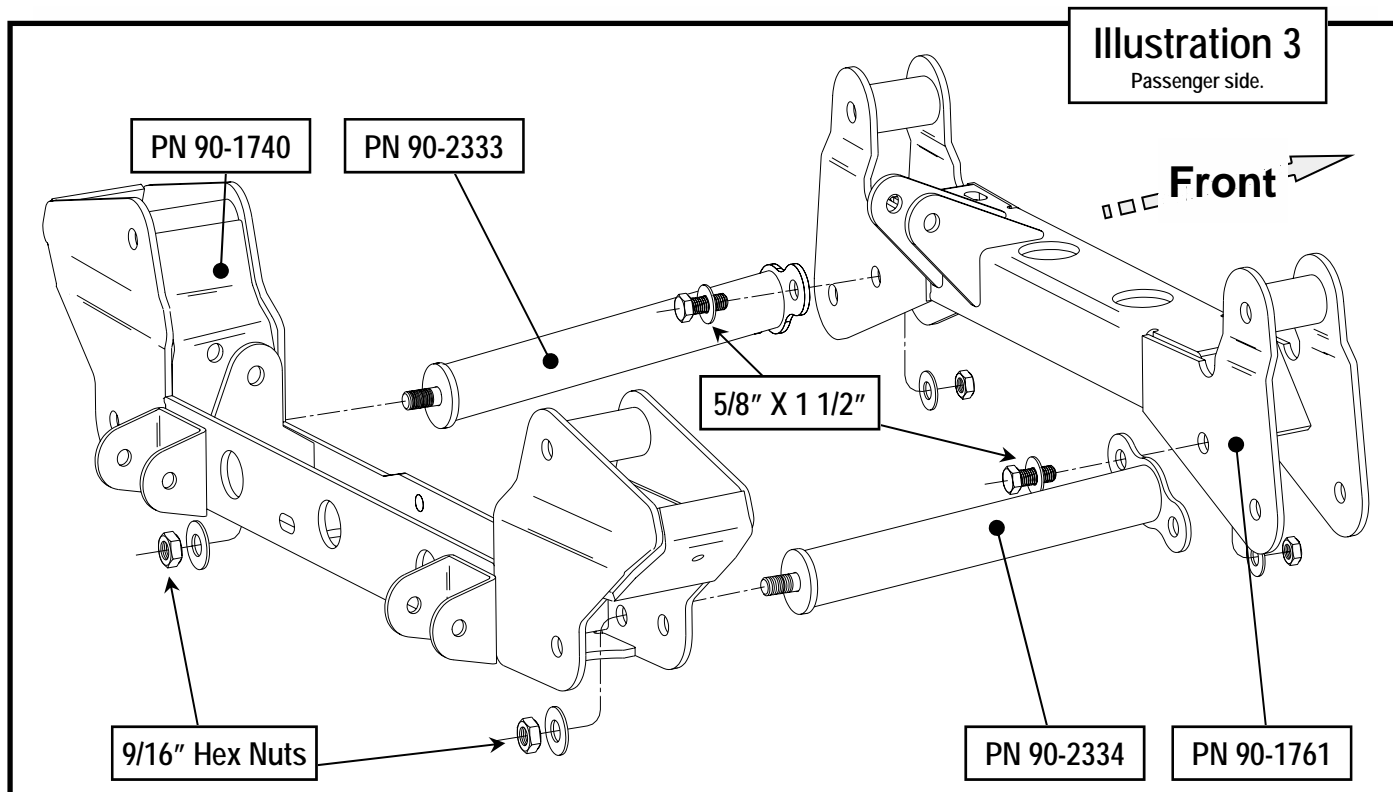

can be found in hardware pack **90-6227**. Make sure the **5"** bolts pass through the cross member brace flanges on both sides of the vehicle. See **Illustration 6**.

24. Install the assembled knuckle to the upper and lower ball joints using the **OE** hardware. Torque the upper ball joint to 37 ft. lbs. and the lower ball joint to 74 ft. lbs.

**Perform steps 22 - 29 on one side of the vehicle at a time.**

25. Loosen the tie rod end jam nut and thread the tie rod end inward two complete turns. Re-tighten the jam nut and attach the tie rod end to

22. Disassemble the **OE** spindles on your work bench. Remove the metric fasteners from the rear of the spindle and remove the bearing cartridge and dust shield.

*Note: Be very careful with the ABS sensor and wire loom that is attached to the bearing cartridge.*

23. Reassemble the Uni-bearing assembly into the new steering knuckle (**PN's 90-4118 Driver, 90-4119 Passenger**). Make sure that the ABS wiring is oriented in exactly the same position as it came from the **OE** knuckle. Torque the bearing to the knuckle with the **OE** bolts. Torque to 133 ft. lbs.

*Important: Now would be an excellent time to make sure the bearing is in good condition.*

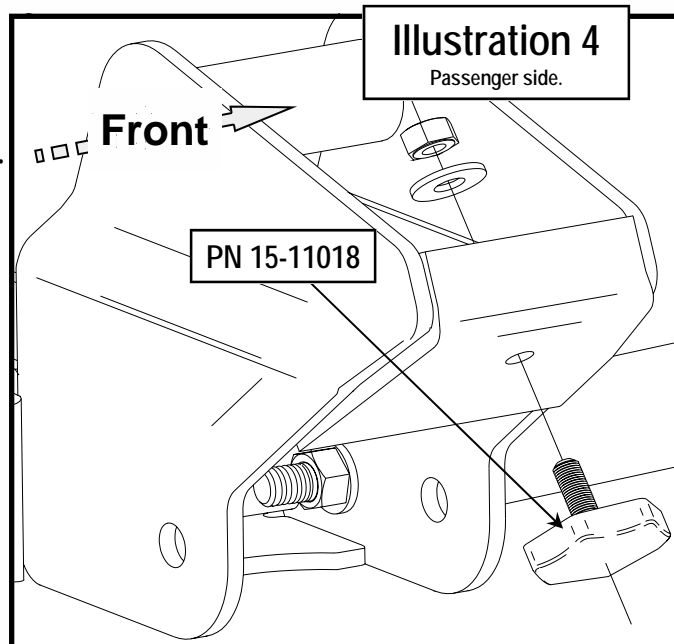

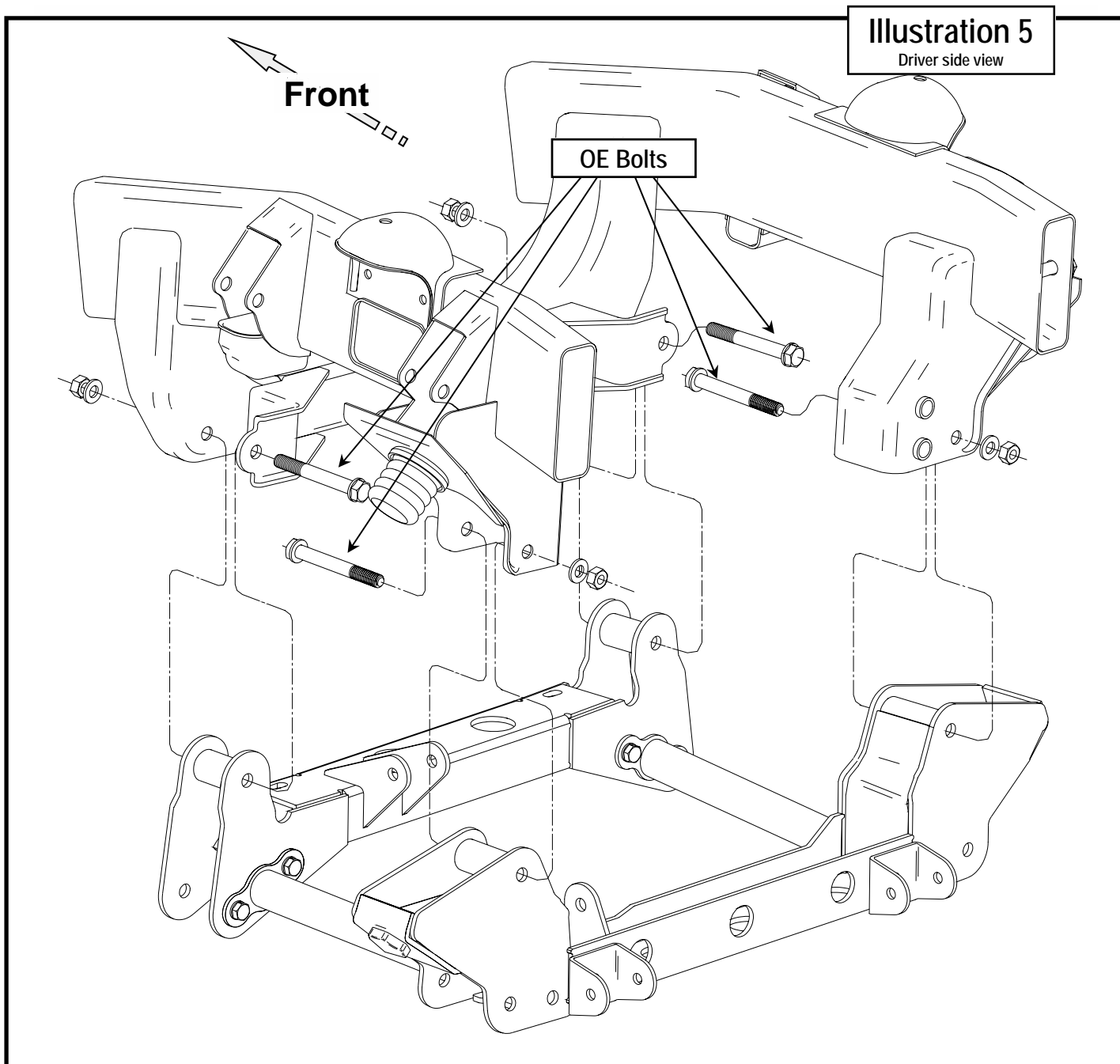

**Illustration 5**  
Driver side view

the new knuckle. Torque the factory nut to 33 ft. lbs.

26. Reinstall the disk brake rotor and caliper. Torque the caliper mounting bolts to 129 ft. lbs. Using a drift or large screwdriver through the caliper, hold the disk firmly. See **Illustration 7** for brake line routing.

27. Slide the brake hose clamp down and attach it to the top hole in the back of the steering

knuckle. Use a clamp bolt from the original knuckle.

28. If you have ABS brakes, attach the ABS cable to the knuckle and upper control arm with zip ties.
29. Use the new hardware from pack **90-6427** to assemble the sway bar linkage. Start by threading one of the lock-nuts onto one end of the threaded rod (**PN 13-90420**) while holding



the threaded rod in your bench vise. Finish the assembly as shown in **Illustration 8**.

---

**Repeat steps 22 thru 29 on the remaining side of the vehicle.**

---

30. Install the new Pro Comp shock absorbers (PN 920590 or MX6019) to the front installation.
31. Assemble the compression strut assemblies as shown in **Illustration 9**. Use the urethane bushings (PN 15-11148) and sleeves (PN 90-2109) from parts pack 90-6263.
32. The compression struts are next. One end is welded at an angle. Install this end into the mounts on the A-arm cross member with the strut angled in toward the center of the vehicle. Use one of the 1/2" X 4" bolts supplied in hardware pack 90-6234 through each front mount and strut. Use **Illustration 9** for a reference.

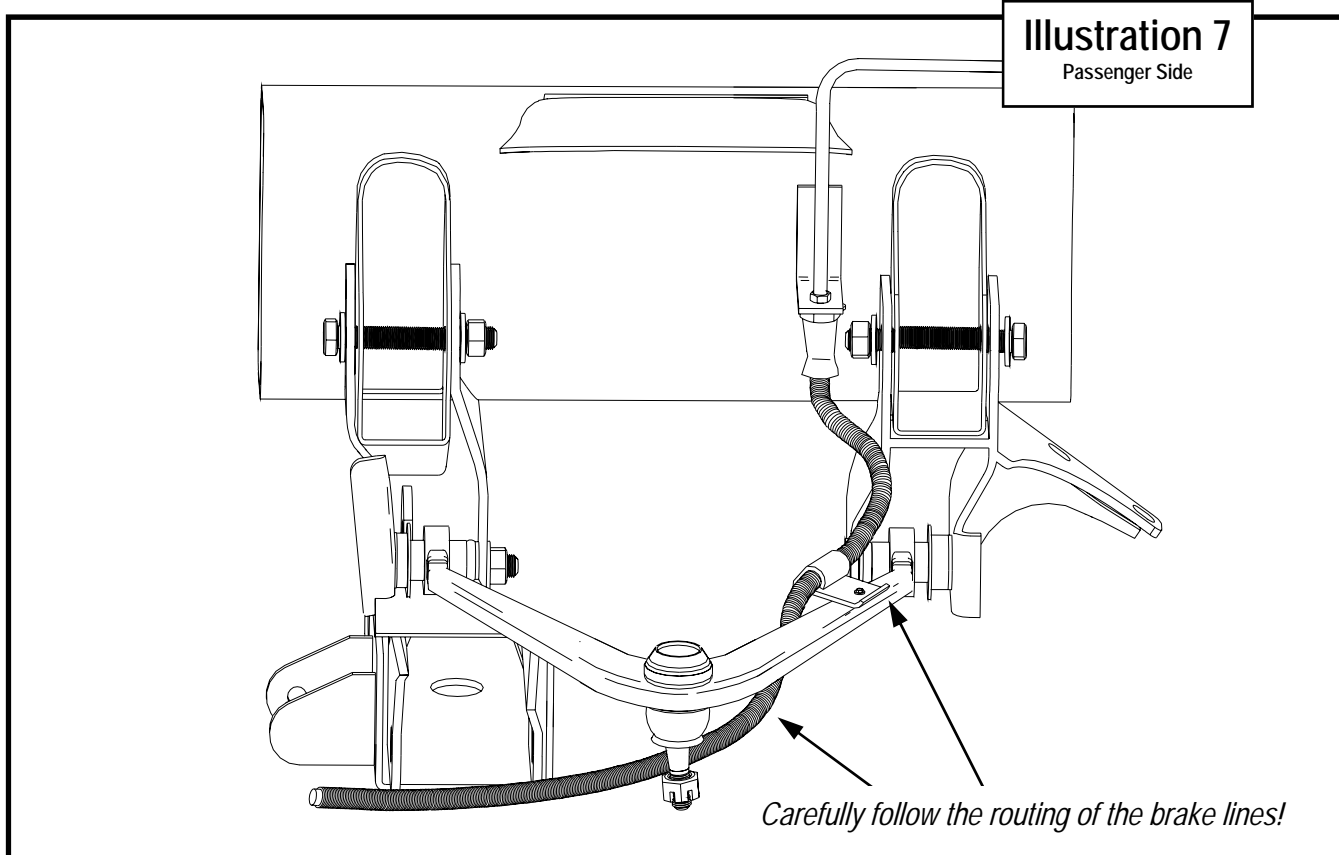
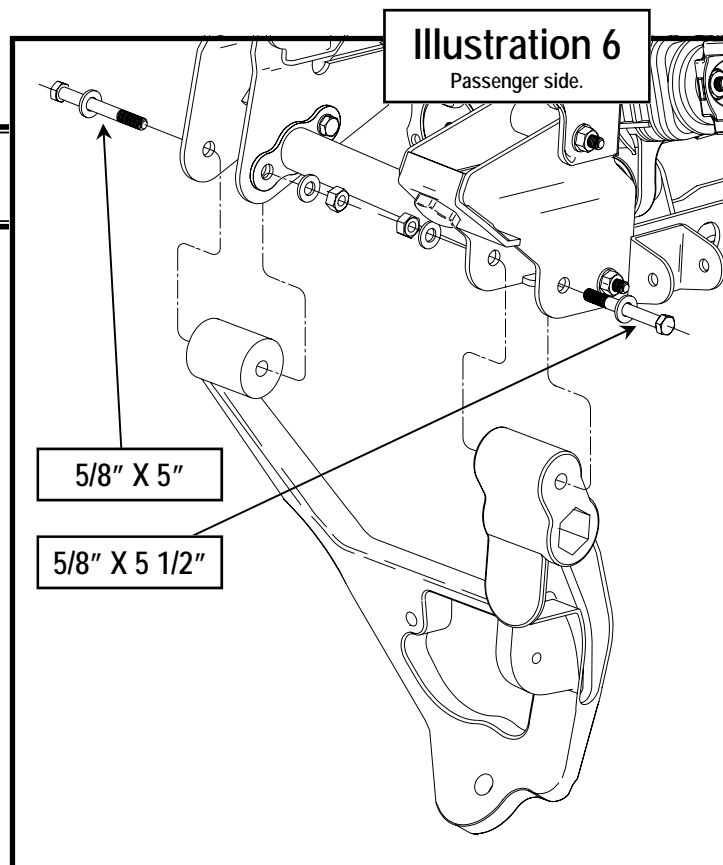

33. Swing the compression strut up and to the rear until it is near the transmission cross member. Hold one of the compression strut mounts (PN 90-1435) in place and rotate it until one of the holes is lined up between the strut mount and an existing hole in the cross member and at the same time is lined up with the compression strut sleeve. Insert one of the 1/2" X 1 1/4" bolts from hardware pack 90-6234 through the mount and frame. Install one of the nut plates (PN 90-1476) over the bolt and snug up the bolt. Install another 1/2" X 4" bolt through the compression strut mount end as shown in **Illustration 9**. Repeat this procedure for the remaining side. Torque the compression strut hardware to spec.

34. Place the torsion drop bracket 90-1635 under the frame rail directly below the OE cross member bracket. Clamp them firmly in place with vise-grips or C-clamps.

*Note: the large holes in the bracket should be very close to centered over the rivets at the bottom of the vehicle frame.*

*Caution: Make sure you check the inside of the frame before proceeding with the next operation. Make sure no wiring harnesses or brake lines are in the way!*

35. Mark and center punch the two bottom and two side mount holes. See **Illustration 10**. Drill the holes to 7/16" and install the 7/16" X 1 1/4" bolts from hardware pack 90-6250. Torque these fasteners to spec.

36. Mount torsion drop adapters PN 90-1638 to the torsion drop bracket 90-1635 previously installed using four 3/8" X 1 1/4" bolts from parts pack PN 90-6223 as shown in **Illustration 12**.

37. Insert two bushings and one sleeve into each of the selected adapters. See **Illustration 12**.

38. Attach the cross member to the newly installed adapters using the OE bolts. See **Illustration 12**.

39. Re-install the torsion bars into the front A-

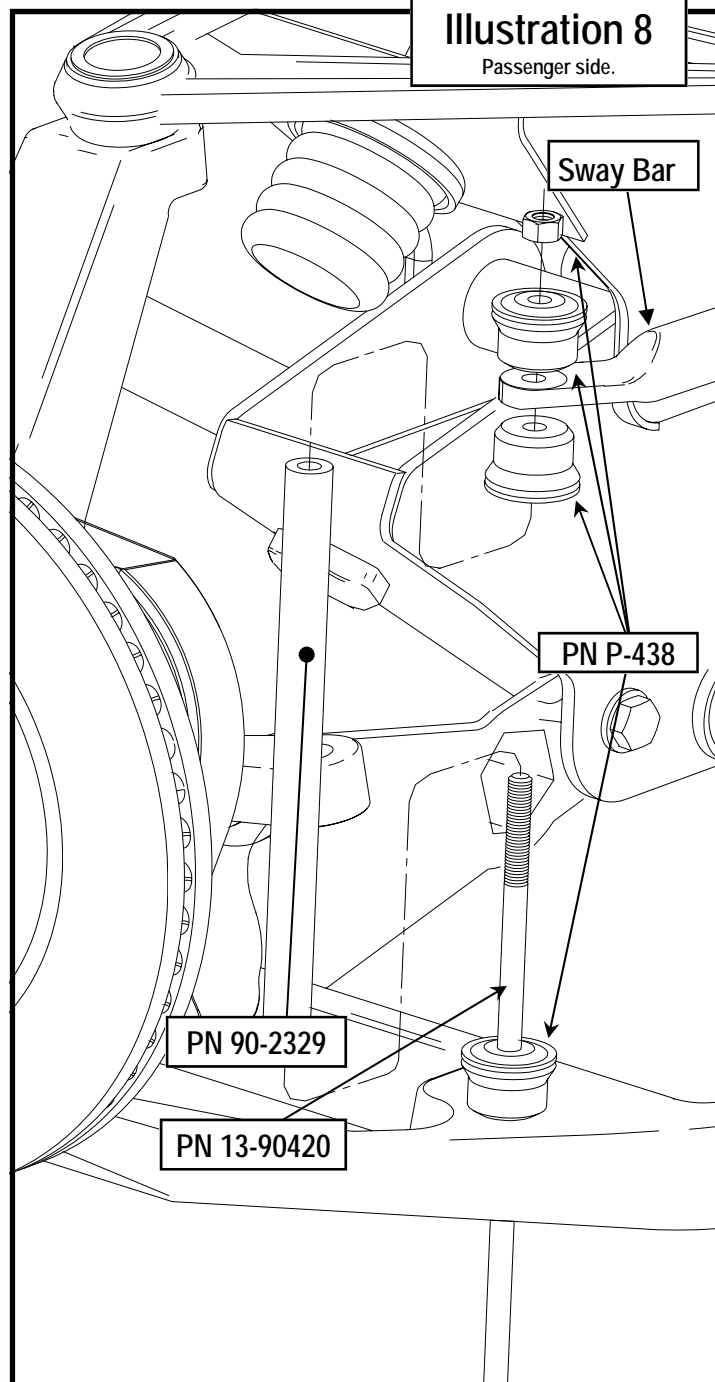

arms in the same positions they occupied prior to installation of the lift kit.

40. Slide one of the torsion bars rearward through the cross member while holding the adjustment arm in its proper position.

41. Use the torsion bar unloading tool and reinstall the torsion bars. Set the adjuster bolt to the same height as previously recorded on page 5.

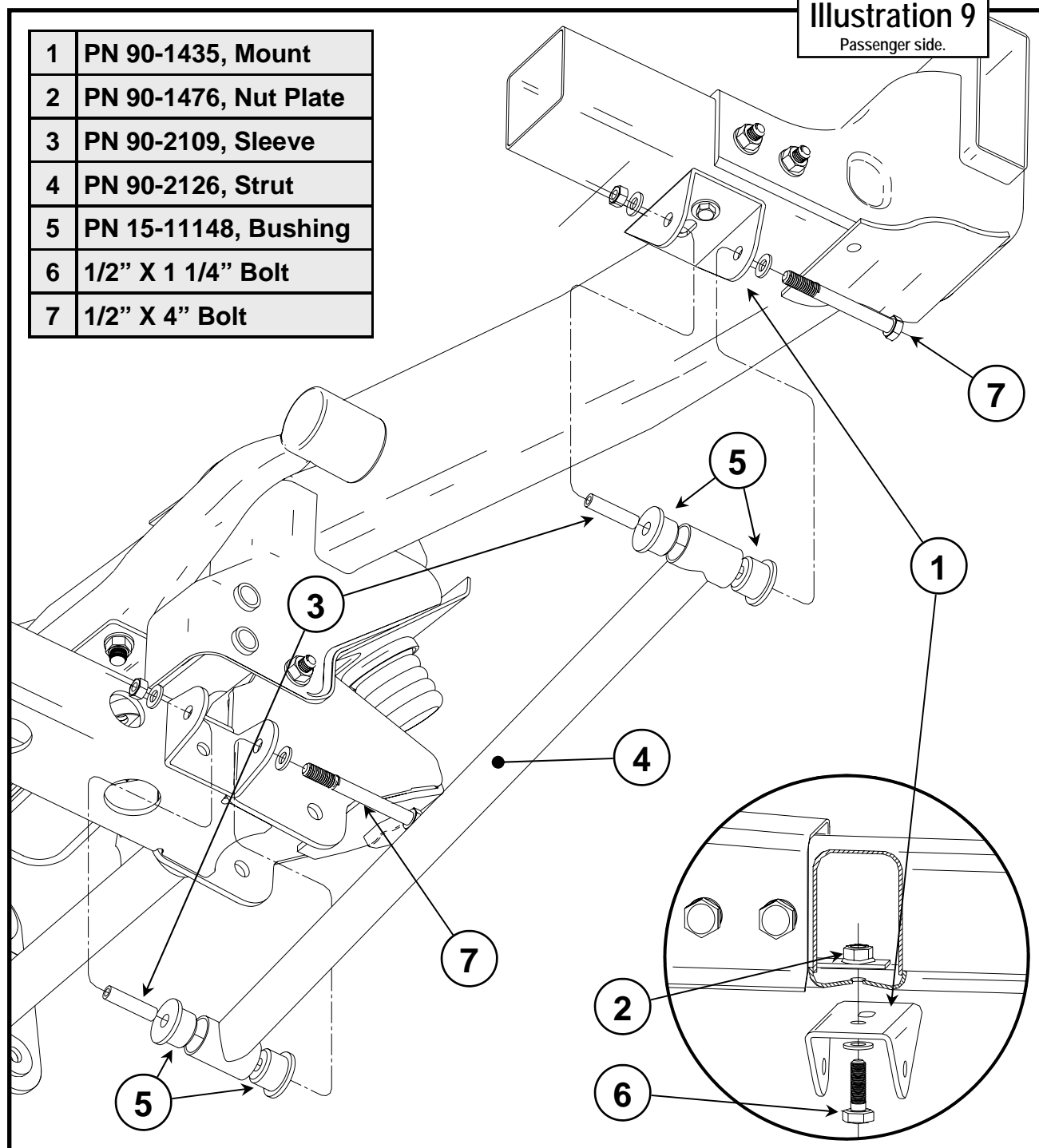

42. Repeat these steps on the remaining side of the vehicle.
43. On both sides of the vehicle, check the routing of the brake lines and the ABS wire harnesses. There must be no pinching, rubbing, or stretching of either component. **Illustration 7** shows an example of the routing. Use zip ties to se-

- cure these items to the steering components. At full droop, cycle the steering from lock to lock while observing the reaction of these components. Reposition them if needed.
44. Install your wheels and tires and lower the vehicle to the ground. Tighten the lug nuts to 110 ft. lbs.

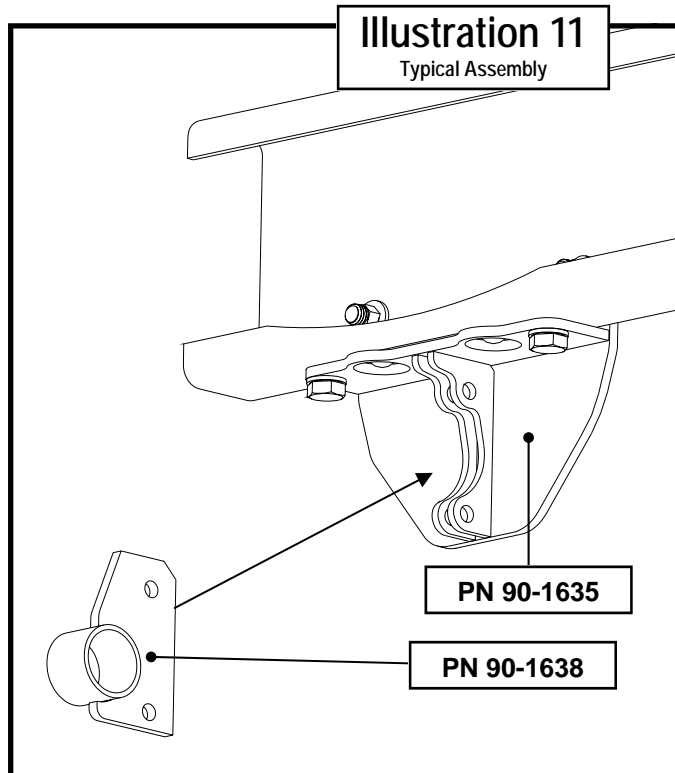
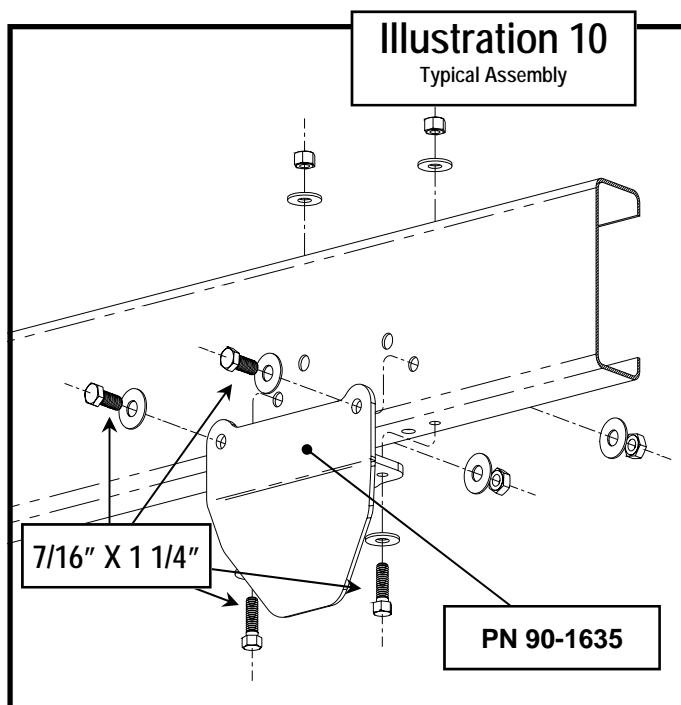

- 45. Torque the lower A-arm bolts to 107 ft. lbs.
- 46. Recheck for proper installation and torque, all newly installed hardware.

**NOTES:**

- ⇒ On completion of the installation, have the suspension and headlights re-aligned.
- ⇒ After 100 miles recheck for proper torque on all newly installed hardware.
- ⇒ Recheck all hardware for tightness after off road use.

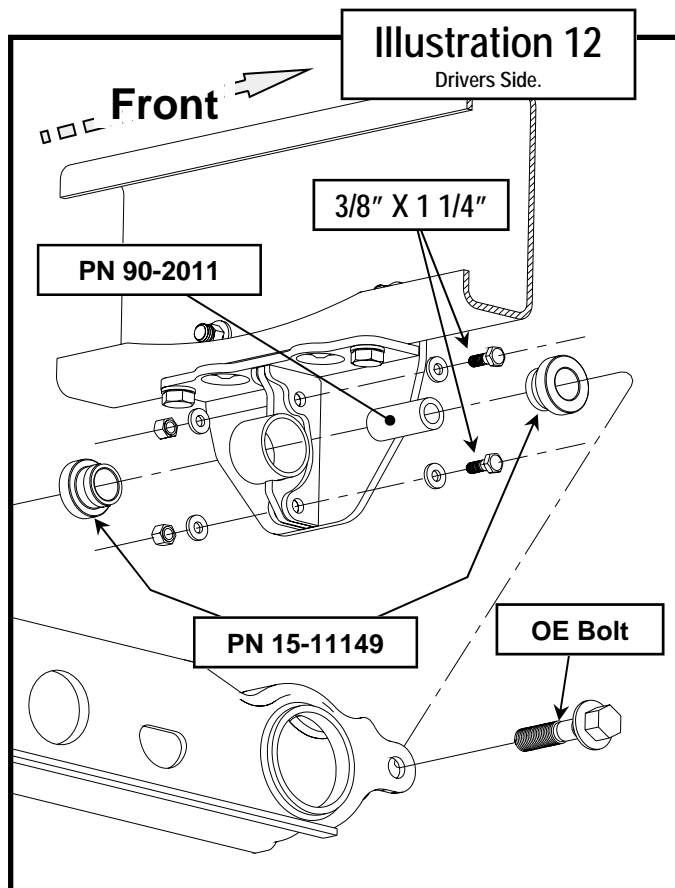

## REAR INSTALLATION

1. Raise the rear of the truck enough for the tires to clear the ground. Block the front tires and use jack stands on the frame to support the truck. Remove the rear tires and wheels.
2. Carefully remove the **OE** shock absorbers. It may be necessary to raise the differential housing slightly to facilitate their removal.
3. One side at a time, support the differential housing on the side being modified. Remove the "U" bolts from that axle end and discard. Carefully lower the differential away from the

**OE** springs. Remove and discard the **OE** riser block from its mount pad. Take careful note of the position of the factory spring packs.

4. Install the riser block (**PN 90-550**), short end to the front, to the mount pad on the axle housing and raise the axle housing until the riser block hole fits around the new leaf spring center bolt.

*NOTE: Make sure the bottom of the riser block sits flat on the axle pad, if not the pin needs to be ground down until it does not hit the axle.*

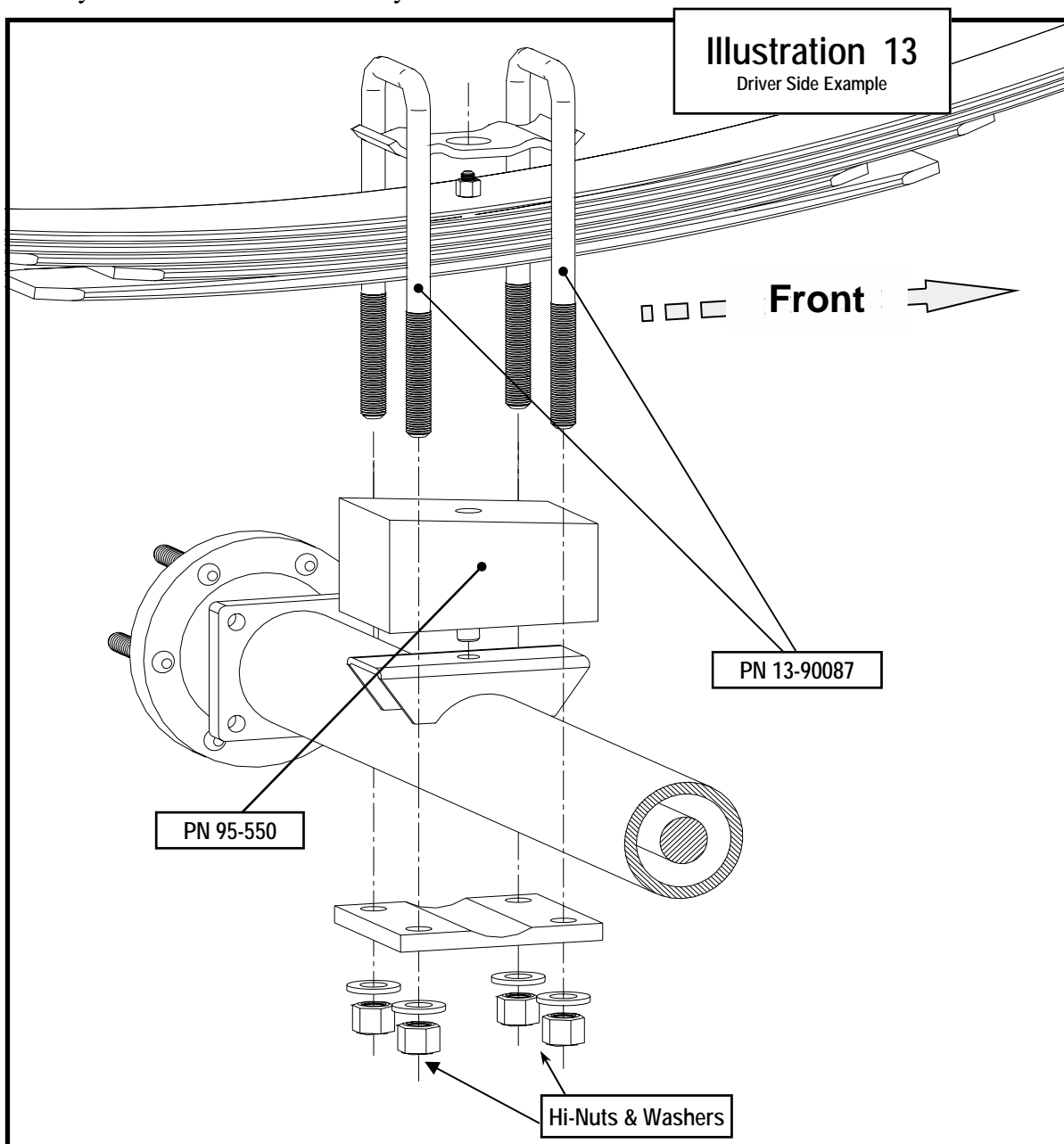

5. Install the new “U” bolts over the leaf spring assembly and using the new washers and nuts supplied along with the existing spring plates, torque the U-bolt nuts to 105 ft./lbs. See **Illustration 13**.
6. Repeat these steps on the other side of the vehicle.
7. Remove the factory bump stops and install the bump stop extensions provided (PN 90-2144). See **Illustration 14**.
8. Before installing your new Pro Comp shock absorbers (PN 927543 or MX6098), it is necessary that you check for adequate clearance. Temporarily install your Pro Comp shocks into the shock mounts with the rod end down and the adjuster knob away from the axle. Carefully check for clearance issues. If there are areas that come in contact with or are very close to your new shocks, carefully remove sufficient material to ensure trouble free operation. Pay particular attention to the area around the lower shock mount. When all clearance issues have been resolved, install your new Pro Comp shock absorbers and recheck all fasteners for proper installation and torque.
9. Install your wheels and tires and lower the vehicle to the ground.
10. After installation is complete, double check that all nuts and bolts are tight. Refer to the chart at the end of this document for torque specifications. (Do not retighten nuts and bolts where Loctite® may have been used).

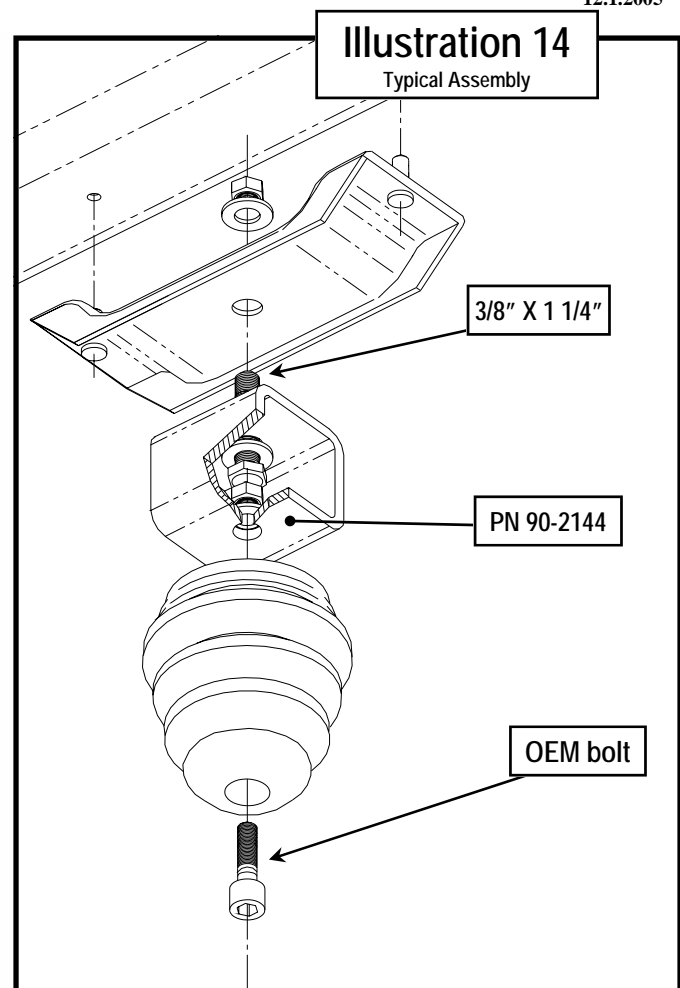

#### **NOTES:**

- ⇒ **On completion of the installation, have the suspension and headlights re-aligned.**
- ⇒ **After 100 miles recheck for proper torque on all newly installed hardware.**
- ⇒ **Recheck all hardware for tightness after off road use.**

## Bolt Torque and ID

### Decimal System

### Metric System

All Torques in Ft. Lbs.

Bolt Size	Grade 5	Grade 8	Bolt Size	Class 9.8	Class 10.9	Class 12.9
5/16	15	20	M6	5	9	12
3/8	30	45	M8	18	23	27
7/16	45	60	M10	32	45	50
1/2	65	90	M12	55	75	90
9/16	95	130	M14	85	120	145
5/8	135	175	M16	130	165	210
3/4	185	280	M18	170	240	290

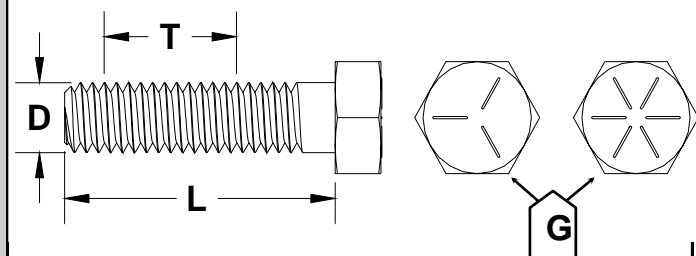

1/2-13x1.75 HHCS

Grade 5    Grade 8  
(No. of Marks + 2)

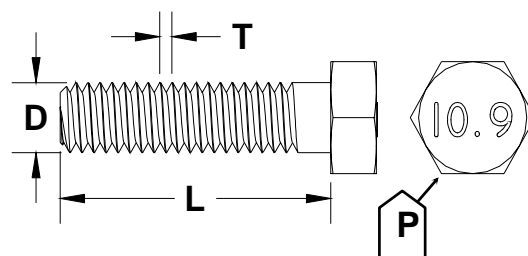

M12-1.25x50 HHCS



G = Grade (Bolt Strength)  
D = Nominal Diameter (Inches)  
T = Thread Count (Threads per Inch)  
L = Length (Inches)  
X = Description (Hex Head Cap Screw)

P = Property Class (Bolt Strength)  
D = Nominal Diameter (Millimeters)  
T = Thread Pitch (Thread Width, mm)  
L = Length (Millimeters)  
X = Description (Hex Head Cap Screw)

**Notice to Owner operator, Dealer and Installer:**

Vehicles that have been enhanced for off-road performance often have unique handling characteristics due to the higher center of gravity and larger tires. This vehicle may handle, react and stop differently than many passenger cars or unmodified vehicles, both on and off-road. You must drive your vehicle safely! Extreme care should always be taken to prevent vehicle rollover or loss of control, which can result in serious injury or even death. Always avoid sudden sharp turns or abrupt maneuvers and allow more time and distance for braking! Pro Comp reminds you to fasten your seat belts at all times and reduce speed! We will gladly answer any questions concerning the design, function, maintenance and correct use of our products.

**Please make sure your Dealer/Installer explains and delivers all warning notices, warranty forms and instruction sheets included with Pro Comp product.**

Application listings in this catalog have been carefully fit checked for each model and year denoted. However, Pro Comp reserves the right to update as necessary, without notice, and will not be held responsible for misprints, changes or variations made by vehicle manufacturers. Please call when in question regarding new model year, vehicles not listed by specific body or chassis styles or vehicles not originally distributed in the USA.

**Please note that certain mechanical aspects of any suspension lift product may accelerate ordinary wear of original equipment components.** Further, installation of certain Pro Comp products may void the vehicle’s factory warranty as it pertains to certain covered parts; it is the consumer’s responsibility to check with their local dealer for warranty coverage before installation of the lift.

**Warranty and Return policy:**

Pro Comp warrants its full line of products to be free from defects in workmanship and materials. Pro Comp’s obligation under this warranty is limited to repair or replacement, at Pro Comp’s option, of the defective product. Any and all costs of removal, installation, freight or incidental or consequential damages are expressly excluded from this warranty. Pro Comp is not responsible for damages and / or warranty of other vehicle parts related or non-related to the installation of Pro Comp product. A consumer who makes the decision to modify his vehicle with aftermarket components of any kind will assume all risk and responsibility for potential damages incurred as a result of their chosen modifications. Warranty coverage does not include consumer opinions regarding ride comfort, fitment and design. Warranty claims can be made directly with Pro Comp or at any factory authorized Pro Comp dealer.

**IMPORTANT!** To validate the warranty on this purchase please be sure to mail in the warranty card.

**Claims not covered under warranty-**

- Parts subject to normal wear, this includes bushings, bump stops, ball joints, tie rod ends and heim joints
  - Discontinued products at Pro Comp’s discretion
- Bent or dented product
- Finish after 90 days
- Leaf or coil springs used without proper bump stops
- Light bulbs
- Products with evident damage caused by abrasion or contact with other items
- Damage caused as a result of not following recommendations or requirements called out in the installation manuals
- Products used in applications other than listed in Pro Comp’s catalog
- Components or accessories used in conjunction with other manufacturer’s systems
- Tire & Wheel Warranty as per Pro Competition Tire Company policy
- Warranty claims without “Proof of Purchase”
- Pro Comp Pro Runner coil over shocks are considered a serviceable shock with a one-year warranty against leakage only. Rebuild service and replacement parts will be available and sold separately by Pro Comp. Contact Pro Comp for specific service charges.
- Pro Comp accepts no responsibility for any altered product, improper installation, lack of or improper maintenance, or improper use of our products.

E-Mail: [tech@explorerprocomp.com](mailto:tech@explorerprocomp.com)  
Website: [www.explorerprocomp.com](http://www.explorerprocomp.com)  
Fax: (619) 216-1474  
Ph: (619) 216-1444

<u>PLACE</u>
<u>WARRANTY REGISTRATION</u>
<u>NUMBER</u>
<u>HERE:</u> _____