

2360 Boswell Road  
Chula Vista, CA 91914  
Phone 619.216.1444  
Fax 619.216.1474  
E-Mail tech@explorerprocomp.com



## PRO COMP SUSPENSION

---

*Suspension Systems that Work!*

**Part # 51947/51947MX**  
**6" Lift**  
**2007 Chevrolet**  
**Tahoe 4WD Kit**  
**With Out Front Driveshaft**

This document contains very important information that includes warranty information and instructions for resolving problems you may encounter. Please keep it in the vehicle as a permanent record.

## Box 1 of 7-PN 51947/51947MX-1

Part #	Description	Qty.	Illus.	Page
90-3575	FRONT FENDER RELOCATION BRACKET- Drvr	1	19	18
90-3576	FRONT FENDER RELOCATION BRACKET- Pass	1	-	-
90-6236	<b>HARDWARE PACK: Track Bar</b>	1	-	-
70-0563501800	9/16" X 3 1/2" GR. 8 HEX BOLT	1	20	19
70-0563001800	9/16" X 3" GR. 8 HEX BOLT	2	-	-
72-056100816	9/16" GR. 8 STOVER NUT	3	20	19
73-05600034	9/16" SAE HARDENED WASHER	6	20	19
70-0431251800	7/16" X 1 1/4" GR. 8 HEX BOLT	2	20	19
72-043100816	7/16" GR. 8 STOVER NUT	2	20	19
73-04300034	7/16" SAE HARDENED WASHER	4	20	19
70-0311001800	5/16" X 1" GR. 8 HEX BOLT	1	20	19
72-031100816	5/16" GR. 8 STOVER NUT	1	20	19
73-03100034	5/16" SAE HARDENED WASHER	2	20	19
90-1785	REAR CONTROL ARM DROP BRACKET: Drvr	1	26	22
90-1790	REAR CONTROL ARM DROP BRACKET: Pass	1	-	-
90-6276	<b>HARDWARE PACK: Rear Control Arm</b>	1	-	-
70-0563501800	9/16" X 3 1/2" HEX BOLT GR. 8	2	26	22
70-0564001800	9/16" X 4" HEX BOLT GR. 8	2	26	22
72-056100816	9/16" GR. 8 STOVER NUT	4	26	22
73-05600034	9/16" SAE HARDENED WASHER	8	26	22
70-0501251800	1/2" X 1 1/4" HEX BOLT GR. 8	2	26	22
72-050100816	1/2" GR. 8 STOVER NUT	2	26	22
73-05000034	1/2" USS HARDENED FLAT WASHER	4	26	22
90-6235	<b>HARDWARE PACK: Rear Sway Bar/Rear Brake Line</b>	1	-	-
P-843	SHOCK BOLT	2	24	21
60859H	5/8"X 12mm X 1.480 SLEEVE	2	24	21
45359	5/8" RUBBER HOURGLASS	4	24	21
90-55089-4	FRONT BRAKE LINE EXTENSION	1	21	19
90-2311	SWAY BAR EXTENSION	2	24	21
90-5400	TRACK BAR RELOCATION BRACKET	1	20	19
90-6244	<b>HARDWARE PACK: Bump Stop</b>	1	-	-
90-3146	BUMPSTOP SPACER	4	22	20
90-1702	NUT PLATE	2	22	20
70-0371501800	3/8" X 1 1/2" USS GR. 8 HEX BOLT	4	22	20
73-03700836	3/8 GR. 8 LOCK WASHER	4	22	20
90-3701	DIFF MOUNT-Drvr	1	4	10
90-3704	DIFF MOUNT-Pass	1	5	10
90-4077	CV SPACER	2	11	13
90-6513	<b>HARDWARE PACK: Front Diff Mount Support Bracket</b>	1	-	-
70-0311001800	5/16"-18 X 1" HEX BOLT GR.	4	8	12
72-031100816	5/16"-18 NYLOCK NUT .	4	8	12
73-04300034	5/16" SAE FLAT WASHER GR. 8	8	8	12

Part #	Description	Qty.	Illus.	Page
<b>90-6514</b>	<b>HARDWARE PACK: Diff Mount Drvr</b>	<b>1</b>	-	-
70-0501751800	1/2"-13 X 1 3/4" HEX BOLT GR. 8	2	6	11
72-050100816	1/2"-13 STOVER NUT	2	6	11
73-05000034	1/2" SAE FLAT WASHER GR. 8	4	6	11
<b>90-6251</b>	<b>HARDWARE PACK: Differential</b>	<b>1</b>	-	-
70-0564001800	9/16"-12 X 4" HEX BOLT GR. 8	1	8	12
70-0561751800	9/16"-12 X 1 3/4" HEX BOLT GR. 8	2	6,8	11,12
72-056100816	9/16"-12 STOVER NUT	3	6,8	11,12
73-05600034	9/16" SAE FLAT WASHER GR. 8	4	6,8	11,12
73-05600034	9/16" HARDENED FLAT WASHER	2	6,8	11,12
70-0563001800	7/16"-14 X 3" HEX BOLT GR. 8	1	8	12
72-056100816	7/16"-14 STOVER NUT	1	8	12
73-05600034	7/16" SAE FLAT WASHER GR. 8	2	8	12
71-100601251000	*M10-1.5 X 60 HEX BOLT GR. 10.9	16	8	12
73-01008840	M10 USS FLAT WASHER	16	8	12

Box 2 of 7-PN 51947/51947MX-2

<b>90-4157</b>	<b>KNUCKLE: Pass</b>	<b>1</b>	-	-
<b>90-4156</b>	<b>KNUCKLE: Drvr</b>	<b>1</b>	-	-
<b>90-6522</b>	<b>HARDWARE PACK: Adel Clamps</b>	<b>1</b>	-	-
<b>90-3240</b>	<b>ADEL CLAMP</b>	<b>2</b>	<b>14</b>	<b>15</b>
<b>90-6556</b>	<b>HARDWARE PACK: CV Knuckle Spacer Ring</b>	<b>1</b>	-	-
<b>90-3809</b>	<b>CV KNUCKLE SPACER RING</b>	<b>2</b>	-	-
<b>90-6586</b>	<b>HARDWARE PACK: Spare Tire Wheel Spacer</b>	<b>1</b>	-	-
<b>90-3950</b>	<b>SPARE TIRE WHEEL SPACER</b>	<b>1</b>	-	-

Box 3 of 7-PN 51947/51947MX-3

<b>90-3688</b>	<b>REAR CROSSMEMBER</b>	<b>1</b>	<b>9</b>	<b>13</b>
<b>90-2319</b>	<b>COMPRESSION STRUTS</b>	<b>2</b>	<b>16</b>	<b>16</b>
<b>90-6234</b>	<b>HARDWARE PACK: Compression Strut</b>	<b>1</b>	-	-
70-0501251800	1/2" X 1 1/4" GR. 8 HEX BOLT	2	16	16
70-0504001800	1/2" X 4" GR. 8 HEX BOLT	4	16	16
72-050100816	1/2" GR. 8 STOVER NUT	4	16	16
73-05000034	1/2" SAE HARDENED FLAT WASHER	1	16	16
<b>90-3353</b>	<b>COMPRESSION STRUT NUT PLATE</b>	<b>2</b>	<b>16</b>	<b>16</b>
<b>90-1104</b>	<b>COMPRESSION STRUT MOUNT</b>	<b>2</b>	<b>16</b>	<b>16</b>
<b>90-6263</b>	<b>HARDWARE PACK: Compression Struts</b>	<b>1</b>	-	-
15-11148	COMPRESSION STRUT BUSHING	8	16	16
90-2109	SLEEVE, COMPRESSION STRUT	4	16	16

## Box 4 of 7-PN 51947/51947MX-4

Part #	Description	Qty.	Illus.	Page
<b>90-3684</b>	<b>FRONT CROSSMEMBER</b>	<b>1</b>	<b>7</b>	<b>11</b>
<b>90-6284</b>	<b>HARDWARE PACK: Crossmember</b>	<b>1</b>	<b>-</b>	<b>-</b>
70-0624501800	5/8"-11 x 4 1/2" HEX BOLT GR. 8	2	10	13
70-0625501800	5/8"-11 X 5 1/2" BOLT GR. 8	2	10	13
72-06200100512	5/8"-11 STOVER NUT	4	10	13
73-06200030	5/8" SAE FLAT WASHER	8	10	13
<b>90-6498</b>	<b>HARDWARE PACK: Sway Bar Drop</b>	<b>1</b>	<b>-</b>	<b>-</b>
71-100301251000	10mm-1.5 X 30mm 10.9 HEX BOLT	4	15	15
	10mm 10.9 FLAT WASHER	4	15	15
70-0432501800	7/16"-14 X 2 1/2" GR. 8 HEX BOLT	4	15	15
72-043100816	7/16"-14 STOVER NUT	4	15	15
73-04300034	7/16" SAE FLAT WASHER	8	15	15
<b>90-3632</b>	<b>SWAY BAR DROP- Drvr</b>	<b>1</b>	<b>15</b>	<b>15</b>
<b>90-3635</b>	<b>SWAY BAR DROP- Pass</b>	<b>1</b>	<b>-</b>	<b>-</b>
<b>90-3573</b>	<b>BRAKE LINE BRACKETS</b>	<b>1</b>	<b>14</b>	<b>15</b>
<b>90-3574</b>	<b>BRAKE LINE BRACKETS</b>	<b>1</b>	<b>-</b>	<b>-</b>
<b>90-6517</b>	<b>HARDWARE PACK: Brake Line Bracket</b>	<b>1</b>	<b>-</b>	<b>-</b>
70-0313751800	5/16" X 1" GR. 8 HEX BOLT	2	15	15
73-03100830	5/16" FLAT WASHER	4	15	15
72-031100816	5/16" GR. 8 STOVER NUT	2	15	15
70-0251001800	1/4" X 1.0" GR. 8 HEX BOLT	4	15	15
73-02500830	1/4" FLAT WASHER	8	15	15
72-025100816	1/4" GR. 8 NYLOCK NUT	4	15	15
10C75MXPZ	#10-24 X 3/4" PHILLIPS MACHINE SCREW	4	19	18
10CNNEZ	#10-24 NYLOCK NUT	4	19	18
10NWSAZ	#10 SAE FLAT WASHER	8	19	18
8N75TUHZ	#8 X 3/4" HEX BOLT	8	19	18
8N87WFEZ	#8 x 7/8" FENDER WASHER	8	19	18
<b>90-6515</b>	<b>HARDWARE PACK: Front Diff Support Bracket</b>	<b>1</b>	<b>-</b>	<b>-</b>
15-11148	BUSHING, DIFFERENTIAL MOUNT	2	8	12
90-2108	SLEEVE, DIFFERENTIAL MOUNT-2.39"	1	8	12
<b>90-6516</b>	<b>HARDWARE PACK: Front Diff Mount Tabs</b>	<b>1</b>	<b>-</b>	<b>-</b>
90-3691	FRONT DIFFERENTIAL MOUNT TABS	2	8	12
<b>90-3692</b>	<b>FRONT DIFFERENTIAL SUPPORT BRACKET</b>	<b>1</b>	<b>8</b>	<b>12</b>

## Box 5 of 7-PN 51947/51497MX-5

<b>14157</b>	<b>REAR COIL SPRINGS</b>	<b>2</b>	<b>-</b>	<b>-</b>
<b>927543</b>	<b>ES 9000 SHOCK</b>	<b>2</b>	<b>-</b>	<b>-</b>
<b>90-2614</b>	<b>STRUT SPACER</b>	<b>2</b>	<b>13</b>	<b>14</b>

## Box 6 of 7-PN 51947-6

Part #	Description	Qty.	Illus.	Page
<b>90-6317</b>	<b>HARDWARE PACK: Spacer Mount</b>	<b>1</b>	<b>-</b>	<b>-</b>
72-043200810	7/16-20 GR. 8 PLATED HEX NUT	6	13	14
73-04300830	7/16 SAE FLATWASHER ZINC	6	13	14
73-04300836	7/16 SPLIT LOCK WASHER	6	13	14

**OR Box 6 of 7-PN 51947MX-6**

<b>624000</b>	<b>COIL OVER</b>	<b>1</b>	<b>12</b>	<b>14</b>
<b>90-6492</b>	<b>HARDWARE PACK: Coil over mounting spacers</b>	<b>1</b>	<b>-</b>	<b>-</b>
90-2433	UPPER SPACERS	4	12	14
<b>90-3712</b>	<b>COIL OVER MOUNT: Upper Bracket</b>	<b>1</b>	<b>12</b>	<b>14</b>
<b>90-6317</b>	<b>HARDWARE PACK: Spacer Mount</b>	<b>1</b>	<b>-</b>	<b>-</b>
72-043200810	7/16-20 GR. 8 PLATED HEX NUT	6	12	14
73-04300830	7/16 SAE FLATWASHER ZINC	6	12	14
73-04300836	7/16 SPLIT LOCK WASHER	6	12	14
<b>MX6105</b>	<b>MX6 SHOCKS</b>	<b>1</b>	<b>-</b>	<b>-</b>
<b>90-6327</b>	<b>HARDWARE PACK: Spacer Mount</b>	<b>1</b>	<b>-</b>	<b>-</b>
72-0432501800	7/16" X 2 1/2" GR. 8 HEX BOLT	2	12	14
73-04300830	7/16" SAE FLATWASHER ZINC	4	12	14
73-04300816	7/16" STOVER NUT	2	12	14
<b>90-6587</b>	<b>HARDWARE PACK: Coil Over Spacer</b>	<b>1</b>	<b>-</b>	<b>-</b>
<b>90-3956</b>	<b>1/4" Spacer</b>	<b>2</b>	<b>12</b>	<b>14</b>

**OR Box 7 of 7-PN 51947MX-7**

<b>624000</b>	<b>COIL OVER</b>	<b>1</b>	<b>12</b>	<b>14</b>
<b>90-3010</b>	<b>COIL OVER WRENCH: Large</b>	<b>1</b>	<b>-</b>	<b>-</b>
<b>90-3011</b>	<b>COIL OVER WRENCH: Small</b>	<b>1</b>	<b>-</b>	<b>-</b>
<b>90-6318</b>	<b>HARDWARE PACK: Coil Over Mount</b>	<b>1</b>	<b>-</b>	<b>-</b>
70-0502751800	1/2"-13 X 2 3/4" BOLT	2	12	14
73-05000830	1/2" SAE FLATWASHER ZINC	4	12	14
72-050100816	1/2-13 STOVER NUT	2	12	14
<b>90-3712</b>	<b>COIL OVER MOUNT: Upper Bracket</b>	<b>1</b>	<b>12</b>	<b>14</b>
<b>MX6105</b>	<b>MX6 SHOCKS</b>	<b>1</b>	<b>-</b>	<b>-</b>
<b>90-6327</b>	<b>HARDWARE PACK: Spacer Mount</b>	<b>1</b>	<b>-</b>	<b>-</b>
72-0432501800	7/16" X 2 1/2" GR. 8 HEX BOLT	2	12	14
73-04300830	7/16" SAE FLATWASHER ZINC	4	12	14
73-04300816	7/16" STOVER NUT	2	12	14

## Introduction:

- ◆ This installation requires a professional mechanic!
- ◆ We recommend that you have access to a factory service manual for your vehicle to assist in the disassembly and reassembly of your vehicle. It contains a wealth of detailed information.
- ◆ Ensure that your work space is of adequate size and the work surface is level. Place the vehicle in neutral. Place your floor jack under the front cross member and raise vehicle. Place jack stands under the frame rails behind the front wheel wells and lower the frame onto the stands. Remove the jack and place the vehicle back in gear, set the emergency brake, and place blocks both in front and behind the rear wheels.
- ◆ Prior to installation, carefully inspect the vehicle's steering and driveline systems paying close attention to the tie rod ends, ball joints, wheel bearing preload, pitman and idler arm. Additionally, check steering-to-frame and suspension-to-frame attaching points for stress cracks. The overall vehicle must be in excellent working condition. Repair or replace all worn or damaged parts!
- ◆ Read the instructions carefully and study the illustrations before attempting installation! You may save yourself a lot of extra work.
- ◆ Check the parts and hardware against the parts list to assure that your kit is complete. Separating parts according to the areas where they will be used and placing the hardware with the brackets before you begin will save installation time.
- ◆ Check the special equipment list and ensure the availability of these tools.
- ◆ Secure and properly block vehicle prior to beginning installation.
- ◆ **ALWAYS** wear safety glasses when using power tools or working under the vehicle!
- ◆ Use caution when cutting is required under the vehicle. The factory undercoating is flammable. Take appropriate precautions. Have a fire extinguisher close at hand.
- ◆ Foot pound torque readings are listed on the Torque Specifications chart at the end of the instructions. These are to be used unless specifically directed otherwise. Apply Loctite<sup>®</sup> retaining compound where specified.
- ◆ ***Please note that while every effort is made to ensure that the installation of your Pro Comp lift kit is a positive experience, variations in construction and assembly in the vehicle manufacturing process will virtually ensure that some parts may seem difficult to install. Additionally, the current trend in manufacturing of vehicles results in a frame that is highly flexible and may shift slightly on disassembly prior to installation. The use of pry bars and tapered punches for alignment is considered normal and usually does not indicate a faulty product. However, if you are uncertain about some aspect of the installation process, please feel free to call our tech support department at the number listed on the cover page. We do not recommend that you modify the Pro Comp parts in any way as this will void any warranty expressed or implied by the Pro Comp Suspension company.***

## SPECIAL EQUIPMENT

Please refer to your service manual for more information. These tool may be purchased at your local GM dealer.

1. A special removal tool is required for safe removal of the tie rods. (Tie rod puller # **J6627-A**)
2. A special removal tool is required for safe removal of the ball joints. (Ball joint separator tool # **J23742**)
3. A special removal tool is required for safe removal of the coil springs. (Coil spring removal and installation tool # **J23028-A**).

You may be able to rent any of these tools at your local parts store.

## Important!

- Front end and head light realignment is necessary!
  - Speedometer and ABS recalibration will be necessary if larger tires (10% more than stock diameter) are installed.
- ⇒ Due to differences in manufacturing, dimensions and inflated measurements, tire and wheel combinations should be test fit prior to installation. Tire and wheel choice is crucial in assuring proper fit, performance, and the safety of your Pro Comp equipped vehicle. For this application, we recommend a 17" or larger wheel not to exceed 8" in width with a maximum backspacing of 5" must be used. Additionally, a quality tire of radial design, not exceeding 35" tall X 12.5" wide is also recommended. Please note that the use of a 35" X 12.5" tire will require modification to the front fender and front bumper support (*see step 85-98 in the instructions*). Violation of these recommendations will not be endorsed as acceptable by Pro Comp Suspension and will void any and all warranties either written or implied.

## Before You Begin:

- ⇒ Read the instructions and study the illustrations before attempting the installation.
- ⇒ Separating the parts according to the areas where they will be used and placing the hardware with the brackets before you begin will save installation time.
- ⇒ Check the parts and hardware against the parts list to assure that your kit is complete.
- ⇒ ALWAYS wear safety glasses when using power tools or working beneath your vehicle.
- ⇒ Always use NEW cotter pins on re-assembly! (These items are NOT supplied)

***NOTE: REAR COIL SPACERS PN 55496 ARE NOT TO BE INSTALLED  
IN CONJUNCTION WITH REAR COIL SPRINGS PN 14157***

Optional Equipment Available from your Pro Comp Distributor!

COIL OVER UPGRADE KIT: **51957**

Also, check out our outstanding selection of Pro Comp tires to  
compliment your new installation!

## FRONT INSTALLATION:

1. Position your vehicle on a smooth, flat, hard surface (i.e. concrete or asphalt). Block the rear tires and set the emergency brake.
2. Measure and record the distance from the center of each wheel to the top of its fender opening. Record below.

LF: \_\_\_\_\_ RF: \_\_\_\_\_

LR: \_\_\_\_\_ RR: \_\_\_\_\_

3. Place the vehicle in neutral. Place your floor jack under the front axle and raise the vehicle. Place jack stands under the frame rails and lower the frame onto the stands. Remove the jack and place the vehicle back in gear, set the emergency brake, and place blocks both in front and behind the rear wheels.
4. Remove the front wheels from the vehicle.
5. Unclip the ABS bracket from coil bucket and A-arm. Unplug the ABS connector.
6. Unbolt the ABS strap from the steering knuckle. Secure the ABS wire out of the work area. Discard the bracket.
7. Using pliers carefully open the a-arm brake line retaining bracket. Remove the rubber brake hose from the bracket. Using a cut off wheel, cut the bracket at the bend.  
*NOTE: Be very careful to not damage the rubber line in any way during it's removal from the bracket.*
8. Unbolt the brake line bracket from the upper A-arm.
9. Using the proper tool carefully separate the outer tie rod end from the knuckle.
10. Remove the brake caliper and caliper bracket assembly and the rotor. Secure them clear from the work area. **DO NOT** let the caliper hang by the brake line or damage may result.
11. Mark the orientation of the sway bar and remove it from the vehicle.
12. Unbolt and remove the sway bar end links from the vehicle.
13. Unbolt the CV axle from the differential.

14. Using the proper tool carefully separate the upper ball joint from the knuckle. Loosen but **DO NOT** remove the retaining nut from the upper ball joint.
15. Support the lower control arm with a jack and unbolt the lower strut mounting bolts from the lower control arm mount.
16. Unbolt the lower control arm retaining bolts
17. Unbolt the previously loosened upper ball joint retaining nut and remove the lower control arm, knuckle and CV axle assembly from the vehicle.
18. Remove the clips that hold the ABS wire to the upper strut mounting studs.
19. Unbolt the nuts on the upper strut mounting studs. Carefully remove the strut from the vehicle.
20. Unbolt the front driveshaft and from the differential and secure it out of the work area. Save the hardware for reuse.
21. Unplug the differential wiring harness clips and vent tube.
22. Remove the factory rear crossmember support brace from the vehicle and discard. See ILLUSTRATION 1.
23. Support the differential with a jack and unbolt the driver and passenger side mounts (2 per side).

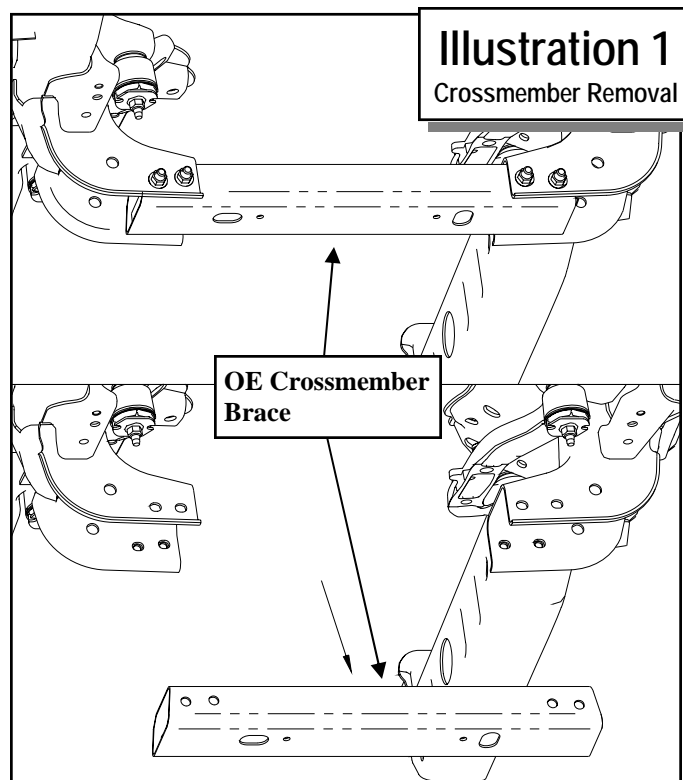



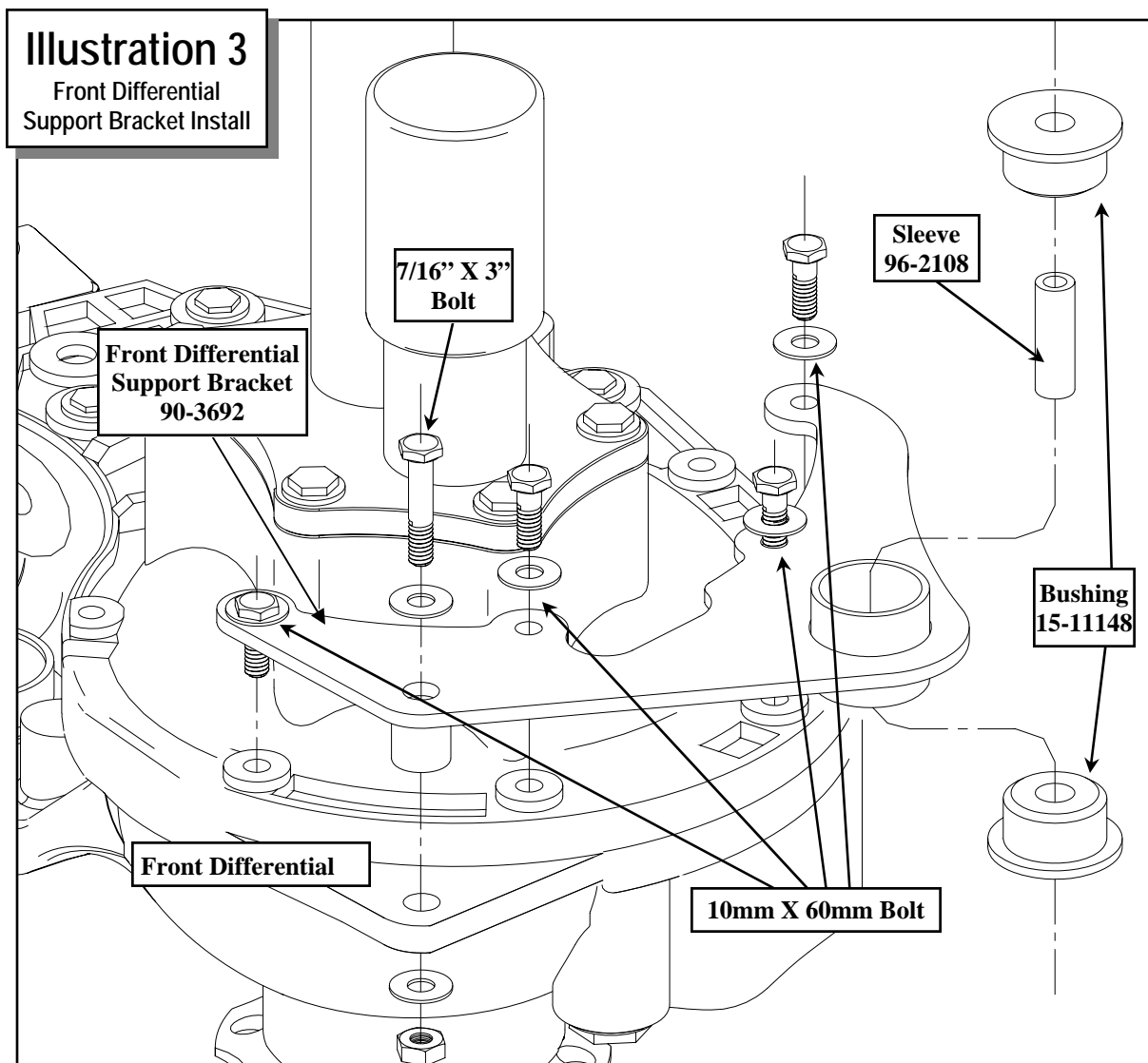
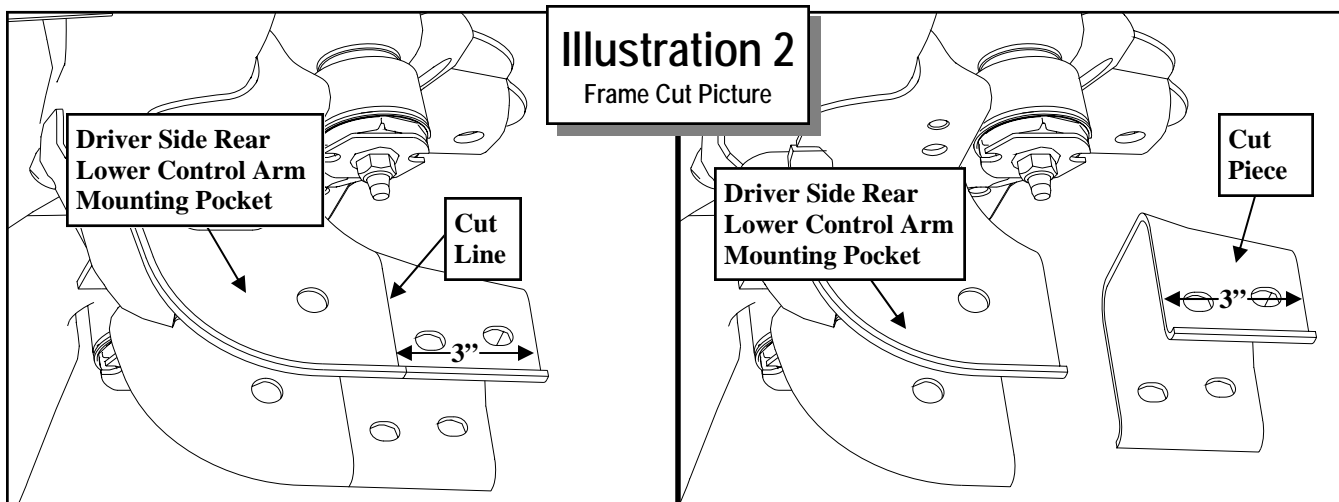

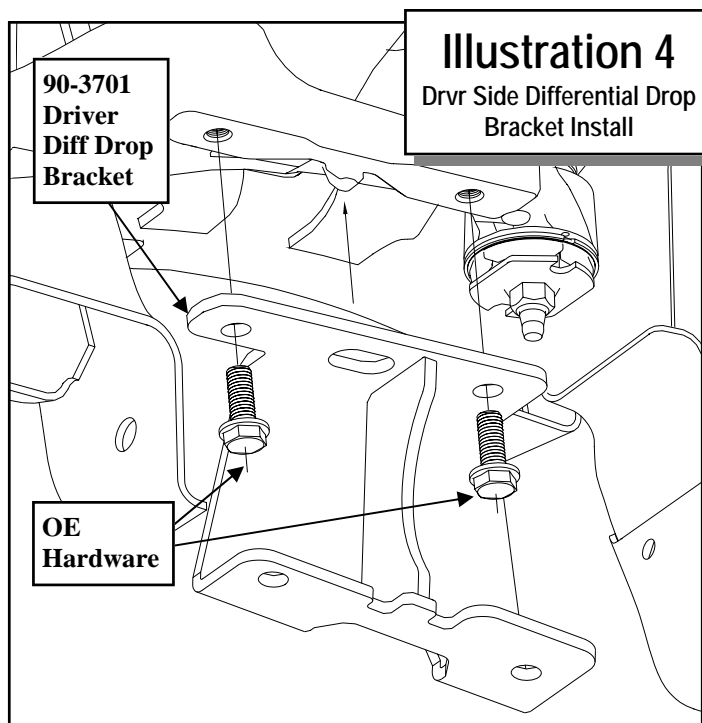

### Illustration 4

Drvr Side Differential Drop Bracket Install

Carefully remove the differential from the vehicle.

24. On the driver side **ONLY**, measure out from the edge of the rear factory crossmember brace mount approximately 3" and scribe a line. See ILLUSTRATION 2.
25. Using a suitable cutting tool, (abrasive cutoff wheel, Sawz-all, etc.) cut the frame along the pre-

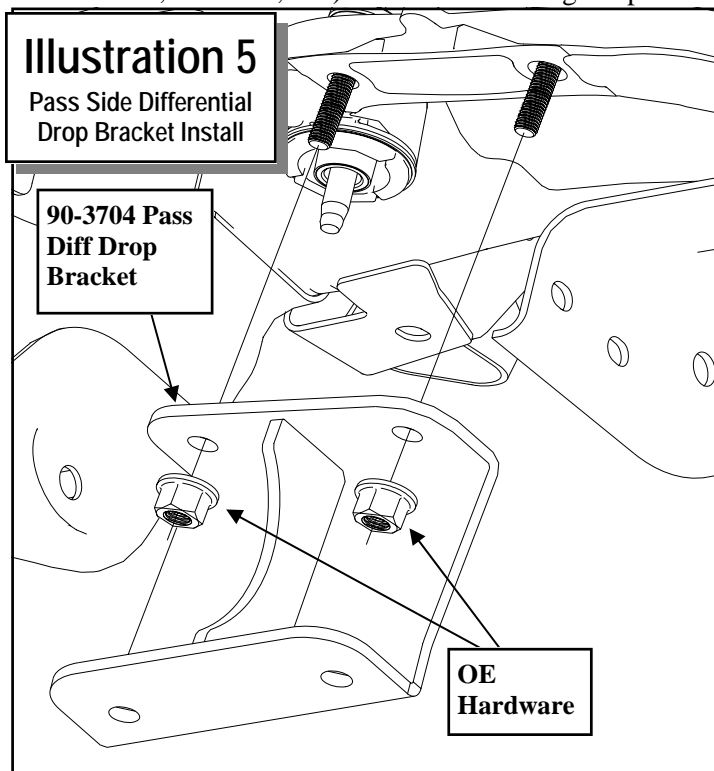

### Illustration 5

Pass Side Differential Drop Bracket Install

90-3704 Pass Diff Drop Bracket

OE Hardware

viously marked lines as shown in ILLUSTRATION 2.

26. Assemble the front differential support bracket (90-3692) using the supplied bushings (15-11148) and sleeves (90-2108) from hardware pack (90-6515). See ILLUSTRATION 3.
27. Rotate the front differential until the case bolt heads are oriented up. Carefully remove the factory bolts from the differential as shown in ILLUSTRATION 3.  
**NOTE:** You will probably notice some differential oil seeping from the area where the bolts are removed. This is normal and not something to worry about. If you do not stand the differential as directed, you will see a LOT more oil on your floor.
28. Place front differential support bracket (90-3692) on the front differential as shown in ILLUSTRATION 3. Secure support bracket using the supplied 10mm X 60mm bolts and washers, 7/16" X 3" bolt and hardware from pack 90-6251. Torque these fasteners to 32 ft. lbs. See ILLUSTRATION 3.

29. Install the driver side differential drop (90-3701) into the factory frame location using the OE bolts and hardware. Hand tighten only. ILLUSTRATION 4.
30. Using the OE hardware, install the passenger side differential drop (90-3704) to the factory frame location as shown in ILLUSTRATION 5.

**IMPORTANT:** The bracket is slightly tapered. The short end of the taper is oriented toward the rear of the vehicle.

31. Secure the differential to the previously installed drop brackets (90-3701 Drvr and 90-704 Pass) using the supplied hardware. Snug all differential mounting hardware to secure the differential location at this time, but **DO NOT** torque at this time. See ILLUSTRATIONS 6.
32. Check clearance between the differential and the trimmed area of the frame. If needed, remove more material until adequate clearance is achieved.
33. After verifying there is an adequate amount of clearance, thoroughly clean and paint the trimmed areas with a good quality paint to prevent rust.
34. Install the front crossmember (90-3684) into the

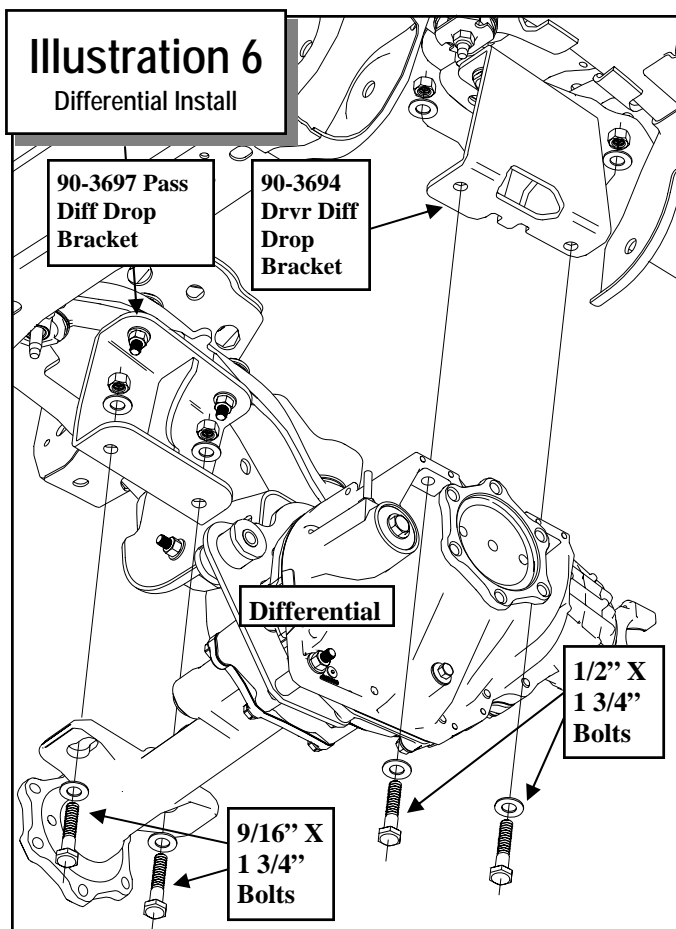

front mounting pockets by sliding one end of the crossmember into the driver side mounting pocket from the outside. Push the installed end of the crossmember as far as it will go to the passenger side in the mounting pocket. Swing the crossmember up into the passenger side pocket. Center the crossmember in the mounting pockets and secure using the **OE** bolts. See ILLUSTRATION 7.

**NOTE: DO NOT cut the front crossmember frame mounting pockets.**

35. Install the front differential tabs (**90-3691**), from hardware pack (**90-6516**), to the lower holes in the welded mounting tabs on the front crossmember using the supplied **5/16" X 1"** bolts and hardware. See ILLUSTRATION 8.

**NOTE: Be sure to bolt the tabs (90-3691) to the outside of the welded crossmember mounting tabs.**

36. Secure the diff mount tabs to the front differential support bracket (**90-3692**) using the using the **9/16" X 4"** bolt and hardware.

37. Install the rear crossmember (**90-3688**) into the rear mounting pockets using the **OE** bolts. See ILLUSTRATION 9.

**NOTE: Be sure to check for clearance against the frame.**

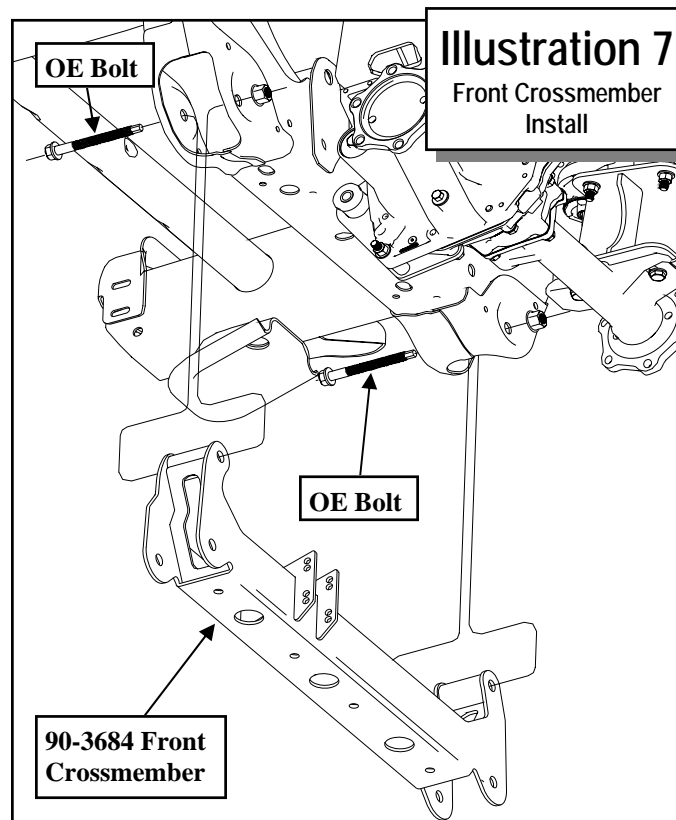

**Illustration 7**  
Front Crossmember  
Install

38. Reinstall the front driveshaft to the front differential using the previously removed **OE** hardware.

39. Reattach the wiring harness, wiring clips and the vent tube to the differential.

**IMPORTANT: Secure the vacuum line out of the way of the steering rack.**

**NOTE: The differential vent tube may need to be carefully pulled down to provide more slack for it's new mounting position.**

40. Unbolt the CV axle retaining nut and remove the CV axle from the **OE** knuckle.

41. Separate the knuckle from the lower control arm and remove the **OE** knuckle.

42. Disassemble the **OE** knuckle on your work bench, remove the bearing hub assembly from the **OE** knuckle by removing the **OE** bolts. Save the mounting bolts, bearing, and dust shield for re-use. Discard the **OE** knuckles.

43. Reassemble the bearing hub and brake dust shields

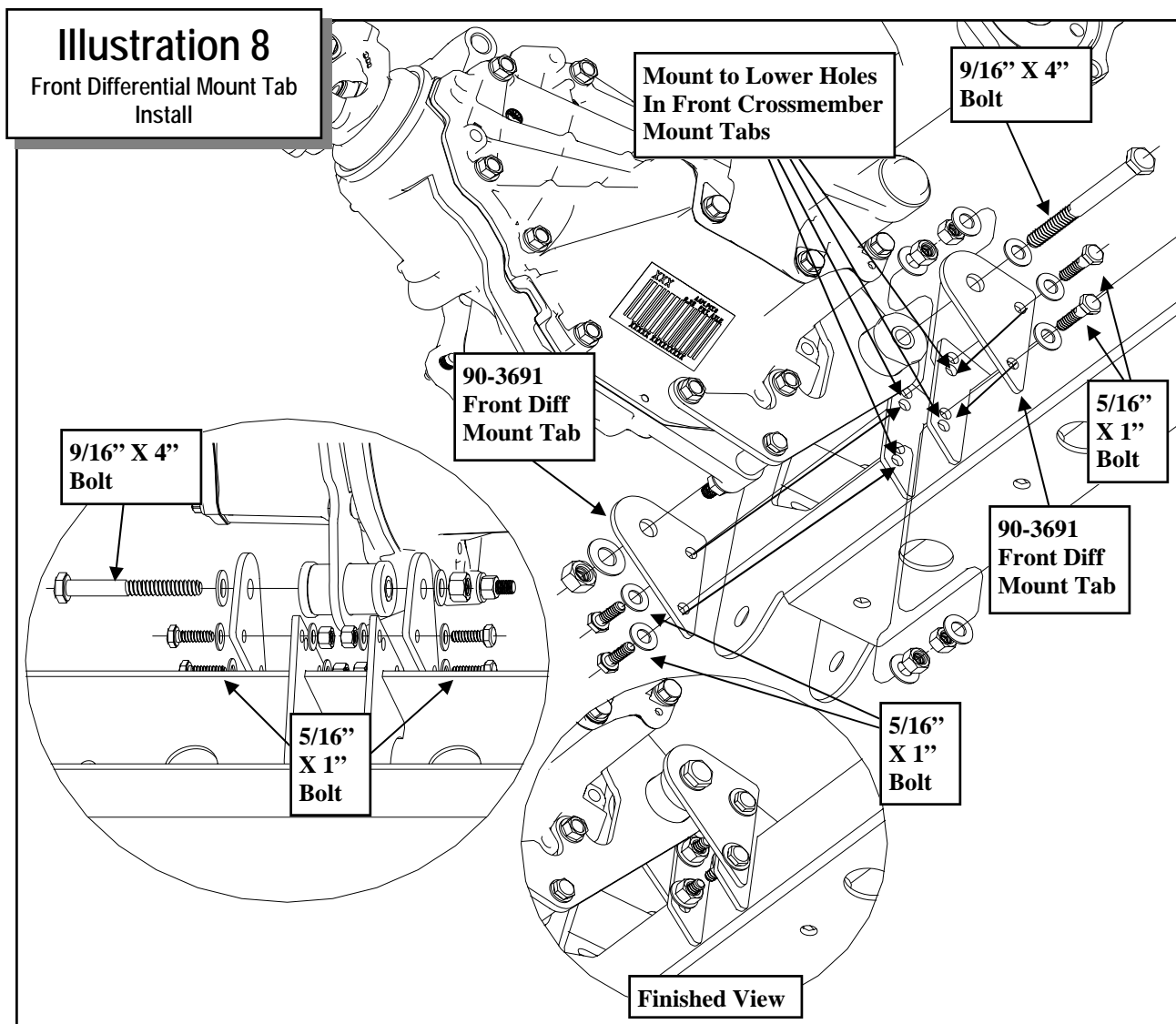

into the new Pro Comp steering knuckle (**90-4156 Drvr** and **90-4157 Pass**). Make sure that the ABS wiring is oriented in exactly the same position as it came from the **OE** knuckle and out of the way of the tire.

44. Torque the bearing to the knuckle with the **OE** bolts. Torque to 133 ft./lbs. Repeat on the other side.
45. Install the lower A-arms into the crossmember mounting pockets. Secure using the supplied **5/8" X 4 1/2"** bolts and hardware in the front pocket and the supplied **5/8" X 5 1/2"** bolts and hardware in the rear pocket.
46. Install the new knuckle to the lower ball joint. Torque the lower ball joint nut 74 ft./lbs.
47. Slip the CV axle through the bearing hub in the knuckle from the inside.
48. Secure the CV axle and the CV spacer (**90-4077**) to the differential using the supplied **10mm X 60mm** bolts and washers. See ILLUSTRATION 11.
49. Install the new knuckle to the upper ball joint. Start the nut and leave hand tight until Coil over installation is complete.
50. Reinstall the CV shaft washer and retaining nut to CV axle. Torque this nut to factory specifications. (See your GM service manual for details)
51. **WITH THE COIL OVERS**, insert the mono ball spacers (**90-2433**) from pack (**90-6492**) in the top of the coil over as shown in ILLUSTRATION 12.

**NOTE:** *The spacers are a tight fit. A press might be needed to fit the spacers into the mono*

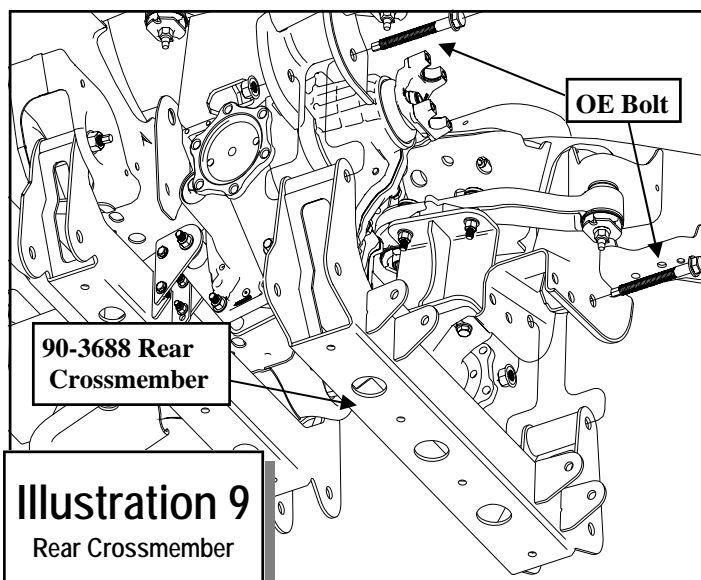

**Illustration 9**  
Rear Crossmember

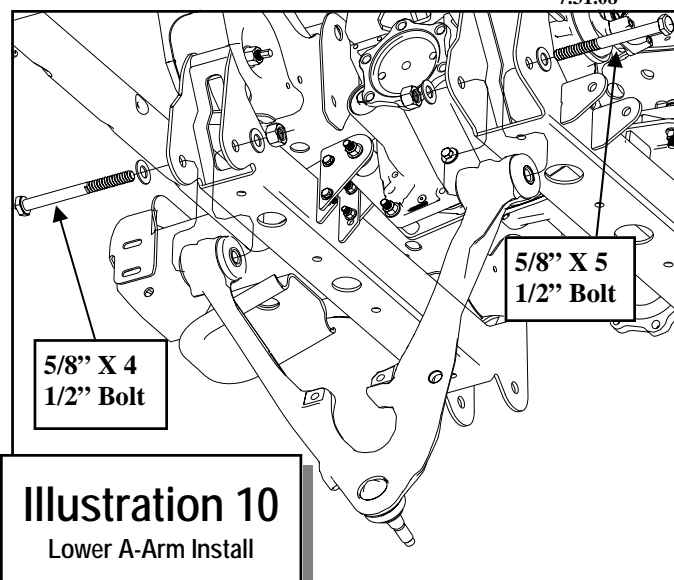

**Illustration 10**  
Lower A-Arm Install

balls.

52. Install the new Pro Comp coil over shock (624000) to the coil over mount upper bracket (90-3712) with the supplied 1/2" X 2 3/4" hardware from hardware pack (90-6318).
53. Install the 1/4" spacer (90-3956) onto the upper coil over mount upper bracket studs. See ILLUSTRATION 12.

**NOTE:** Be sure that the locating tab on the coil spacer is facing toward the outside of the vehicle.

54. Fasten upper bracket to the vehicle using the supplied 7/16" hardware on the top from hardware pack (90-6317) and torque to 45-50 ft./lbs. See ILLUSTRATION 12.
55. Secure the lower coil over shock cross pin to the

lower A-arm using the supplied 7/16" X 2 1/2" bolts and hardware. Torque according to the chart on page 19. See ILLUSTRATION 12.

**NOTE:** Supplemental instructions for MX coil over installation are located in box 51947BMX-6/51957BMX-1.

56. **WITH THE STRUT SPACERS**, attach the strut spacer (90-2614) to the top of the strut using the OE hardware. Torque to manufacturers specifications.
57. Fit the strut and spacer assembly into the stock mounting locations. Fasten using the supplied hardware on the top from hardware pack (90-6317) torque to 45-50ft./lbs. See ILLUSTRATION 5.

**NOTE:** Be sure that the locating tab on the

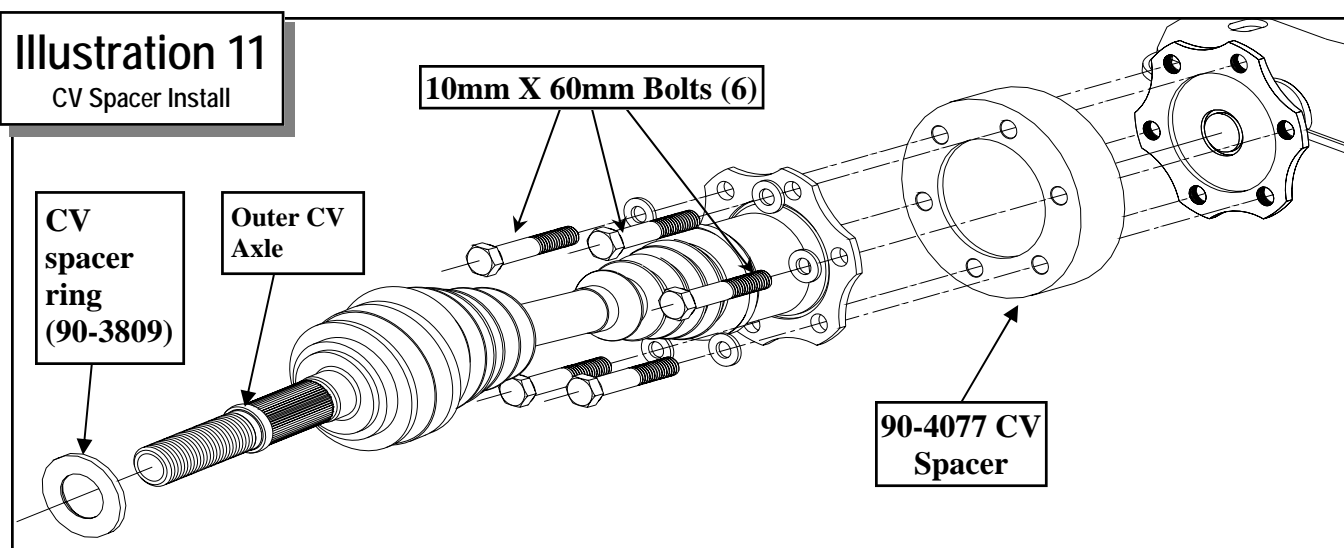

**Illustration 11**  
CV Spacer Install

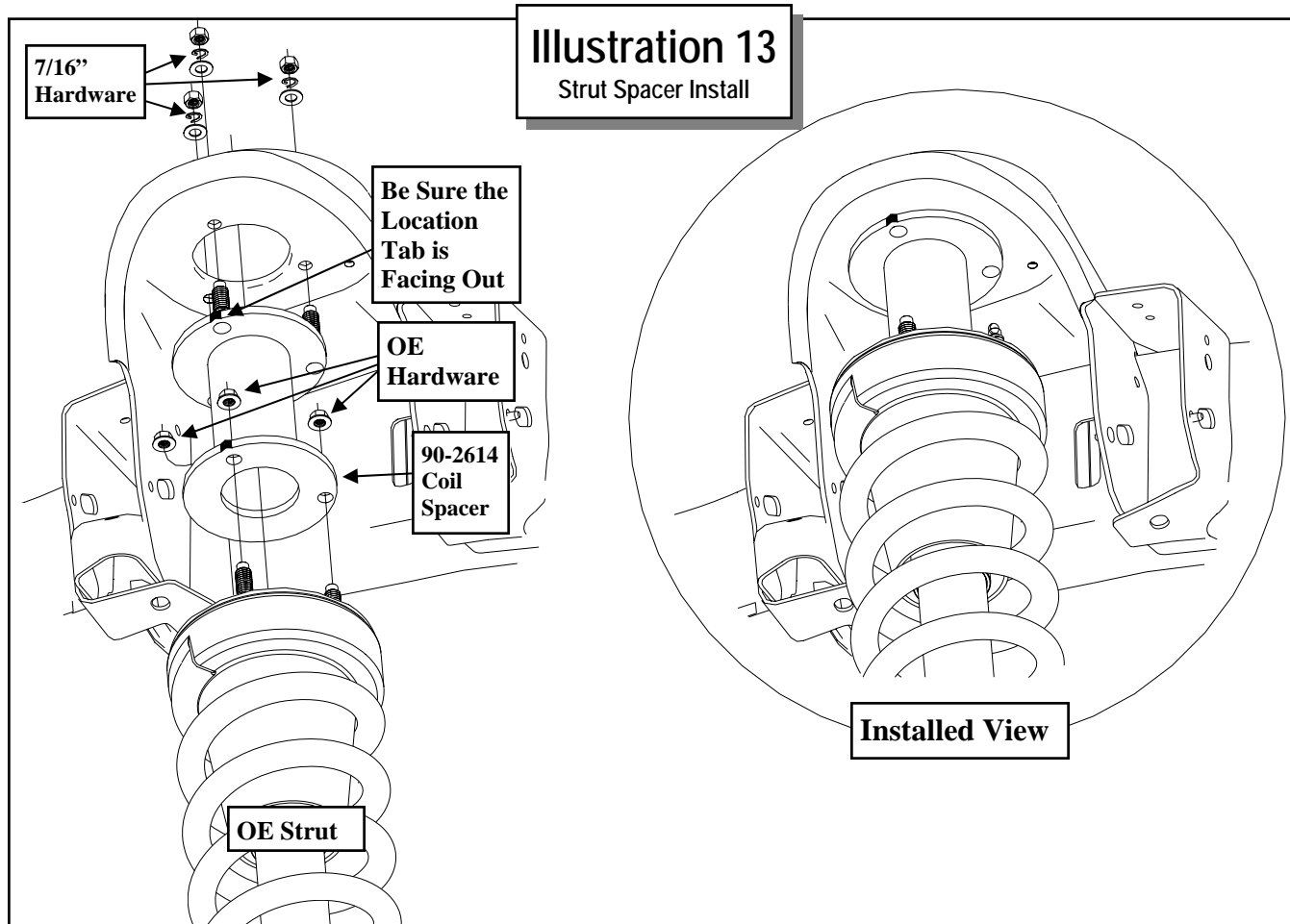
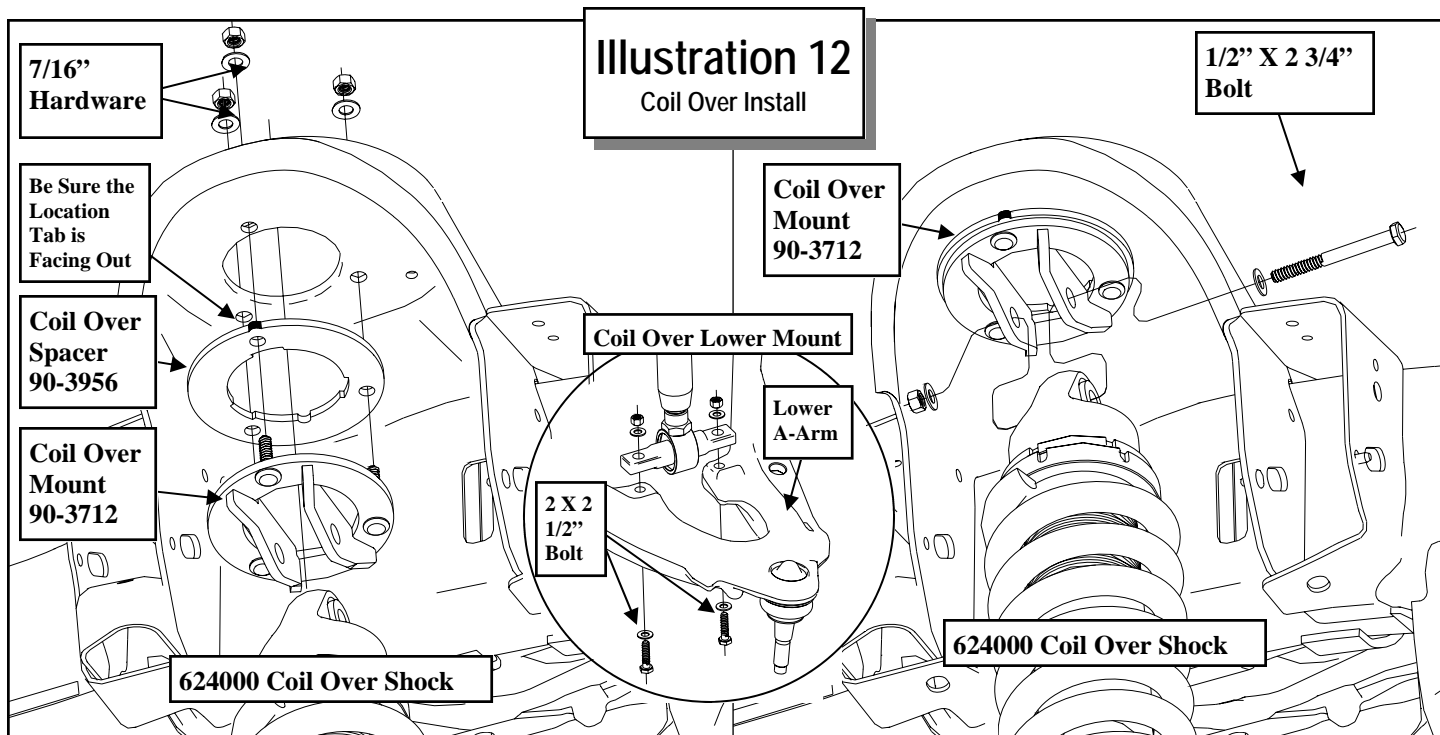

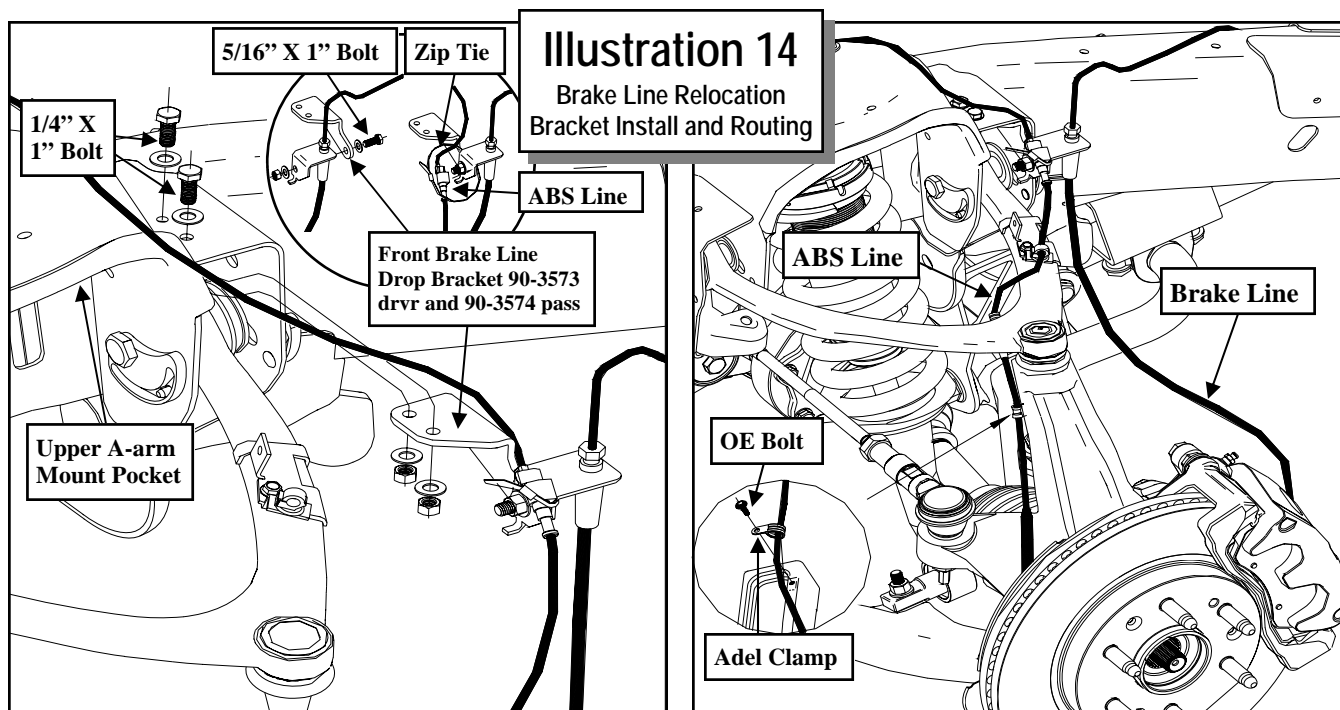

*top ring of the strut spacer is facing toward the outside of the vehicle.*

58. Secure the lower strut cross pin to the lower A-arm using the **OE** bolts. Torque the bolts according to the manufacturers specifications. See ILLUSTRATION 5.
59. Repeat steps 51 through 55 (for use with coil over) or 56 through 58 (for use with OE strut) on the remaining side of the vehicle.
60. Torque the upper ball joint nut to 37 Ft./lbs.

61. Be sure to re-clip the previously removed upper strut mount wiring away from any moving parts, steering shaft or exhaust manifolds.
62. Work on one side of the vehicle at a time.
63. Torque all the differential, upper crossmember bolts and coil over hardware according to the torque chart on page 23 or to factory specifications. **DO NOT** torque the lower A-arm until the vehicle is on the ground.
64. Unbolt the rubber brake line bracket from the upper coil bucket. Discard the **OE** bolt.
65. Unclip the **OE** metal brake lines from the frame clips and carefully bend to provide enough slack in the line for it's new position.  
**NOTE: Be sure that the metal lines do not rub or contact anything.**
66. Install the brake line relocation bracket (**90-3573 drvr** and **90-3574 pass**) to the existing holes in the rear of the upper control arm pocket using the supplied **1/4" X 1"** bolts and hardware. See ILLUSTRATION 14.
67. Bolt the brake line to the previously installed relocation bracket using the supplied **5/16" X 1"** bolt. See ILLUSTRATION 14.
68. Reinstall the rotors and brake calipers to the new knuckle using the previously removed **OE** bolts. Be sure to use thread locker on the caliper bracket

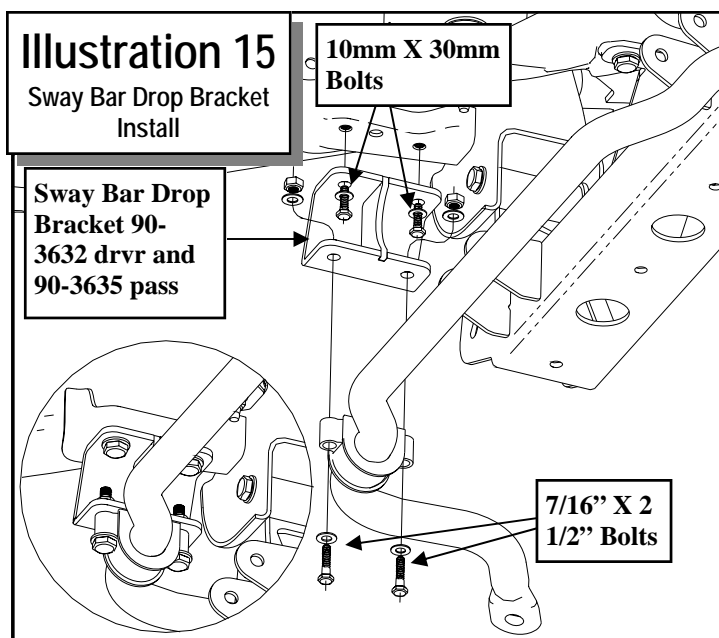

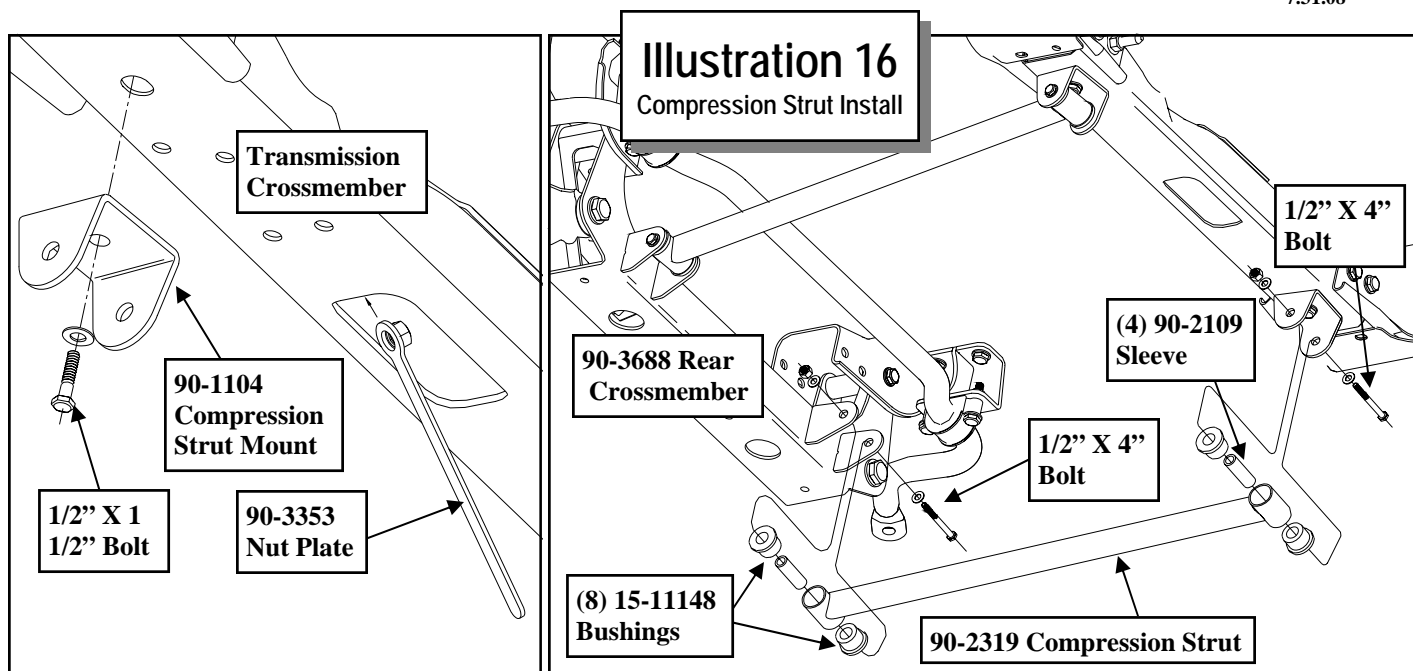

mounting bolts. Torque to factory specifications.

**NOTE:** *It may be necessary to carefully bend the caliper banjo fitting slightly up to provide adequate slack for the brake line. Be very careful not to damage the banjo fitting or brake line in any way. Check tightness of banjo bolt after modification.*

69. Route the ABS wire through the factory clips on the upper A-arm. Zip tie the ABS line to the previously installed brake line bracket. See ILLUSTRATION 14.
70. Reattach the ABS wiring and secure it to the top hole on the knuckle using the supplied Adel clamp and supplied OE bolt and washer. See ILLUSTRATION 14.

**NOTE:** *The Adel clamp has a flat side and a rounded side, make sure the flat side is facing out toward the tire.*

71. On both sides of the vehicle loosen the jam nut and remove the outer tie rod ends and jam nuts.
72. The inner and outer tie rod ends may need to be shortened. Measure in **9/16"** from the end of the inner tie rod end and scribe a line. Measure in **1/2"** from the end of the outer tie rod end and scribe a line. Using a suitable cutting tool, (abrasive cutoff wheel, Sawz-all, etc.) cut the ends along the previously marked line. Be sure the cut is made straight and square or else the jam nut will not hold it's torque properly.

73. Reinstall the outer tie rod ends onto the inner tie rod ends. Thread them on as far as they will go with the stud facing down.

74. Insert from the top and secure the tie rod end to the knuckle and torque to factory specifications

75. Install the sway bar drop brackets (**90-3632** **drv** and **90-3635** **pass**) to the original sway bar mounting holes in the frame, angled toward the rear of the vehicle, using the supplied **10mm-1.5 X 30mm** bolts and hardware. See ILLUSTRATION 15.

76. Using the previously made sway bar orientation markings as a guide, flip the sway bar **180** degrees and reinstall it to the sway bar drop brackets using the supplied **7/16" X 2 1/2"** bolts and hardware. Leave hardware loose at this time. See ILLUSTRATION 15.

77. Install the previously removed OE sway bar end links into their original location on the lower A-arms. See ILLUSTRATION 15.

78. Reconnect the sway bar end links to the sway bar.

79. Torque the sway bar hardware according to the torque chart on page 23.

80. Install the bushings (**15-11148**) and sleeves (**90-2109**) from hardware pack (**90-6263**) into the compression struts (**90-2319**).

81. Using the existing outer holes attach the compression strut mounts (**90-1104**) to the transmission



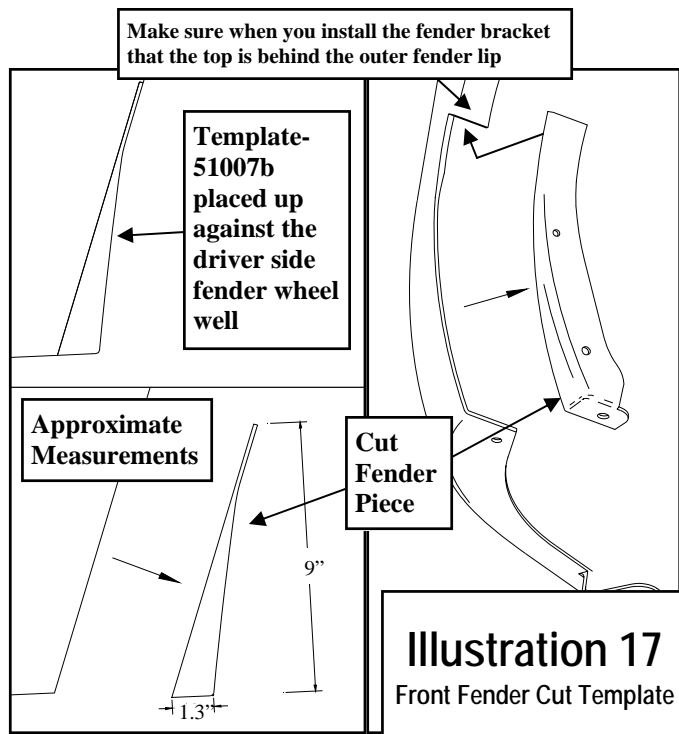

crossmember. Use the supplied  $1/2'' \times 1 1/2''$  bolt and nut plate (90-3353) to secure the mounts to the crossmember. See ILLUSTRATION 16.

82. Rotate the compression struts up and secure them to the crossmember mounts using the supplied  $1/2'' \times 4''$  bolt and hardware. See ILLUSTRATION 16.

*NOTE: The wires can be trimmed off the end of the comp strut nut plates at this time.*

83. Torque compression strut hardware according to the torque chart on page 23.
84. Steps 85 Through 98 are for use with the installation of 35" wheels and tires only.
85. Remove the bolts and/or clips that hold the lower portion of the front inner fender to the front bumper. Secure the inner fender up and out of the work area

86. Tape the supplied cut template (Template-51007b from the consumer pack in box 1) to the outside of the lower front wheel well. See ILLUSTRATION 17.

87. Using the template as a guide, make a guide line on the fender for the cut.

*NOTE: Using tape as a guide will alleviate the need to draw a line on the painted surface of the fender.*

88. Using the marked cut line as a guide, use a very sharp razor knife or a comparable tool and trim the front wheel well for tire clearance. See ILLUSTRATION 17.

*NOTE: A series of light cuts along the cut line will ensure straight cuts without the risk of slipping and cutting too much.*

89. The front lower valence and the front edge of the side steps, in the rear of the front wheel well, will also need to be trimmed for tire clearance. Trim in small increments until the desired amount is achieved.

90. The front bumper inner support bracket will need to be trimmed in order to accommodate the newly trimmed fender. Trim in small increments until the desired clearance is achieved. Save the mounting clip and bolt from the trimmed piece for reinstallation. See ILLUSTRATION 18.

91. Trim the inner fender where it protrudes past the newly cut outer fender lip.

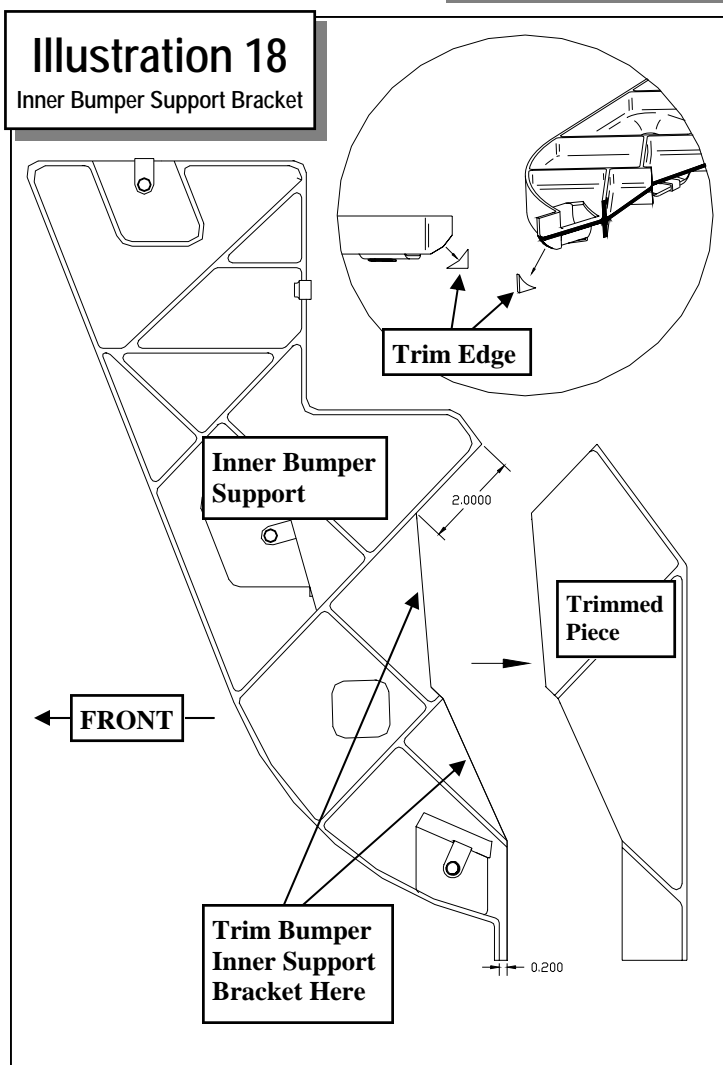

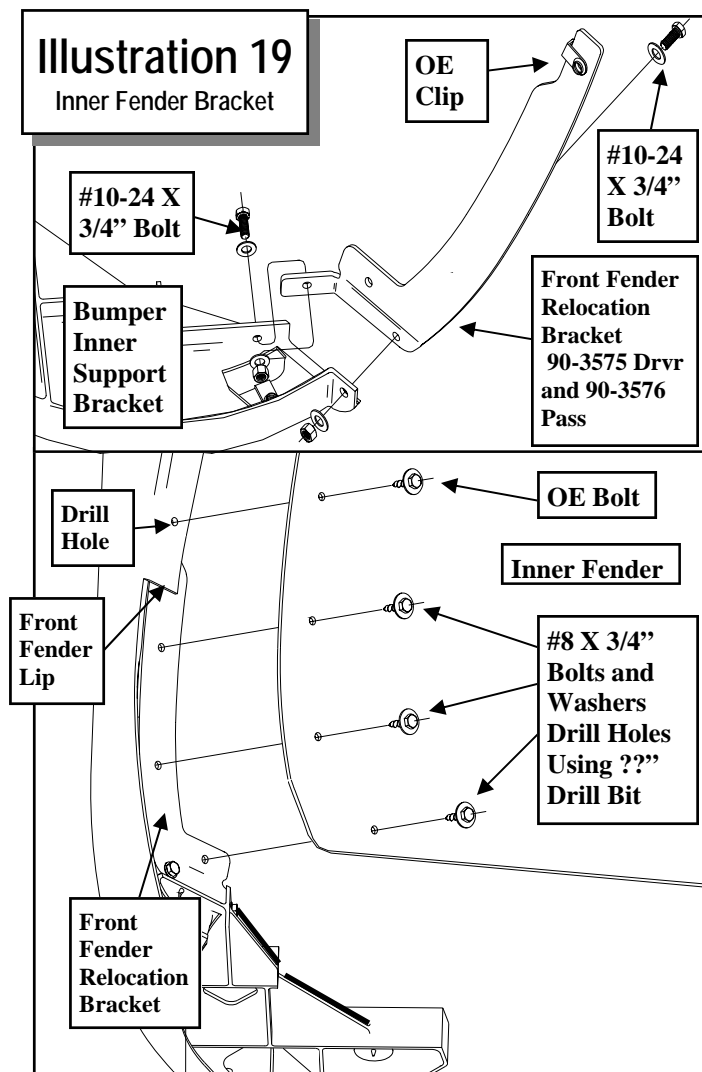

92. Install the front fender relocation bracket (**90-3575 drvr** and **90-3576 pass**) to the bumper inner support bracket. Secure to the bumper support bracket using the supplied **#10-24 X 3/4"** hardware from pack (**90-6517**). See ILLUSTRATION 19.

**NOTE: Make sure when you install the fender relocation bracket that the top is behind the outer fender lip. See ILLUSTRATION 17.**

93. Drill a hole through the fender lip, inner fender and the top tapered portion of the inner fender relocation bracket using a **3/16"** drill bit. See ILLUSTRATION 19.

**NOTE: Be sure to drill the hole in the center of the top tapered portion of the bracket see ILLUSTRATION 19.**

94. Place the **OE** mounting clip over the newly drilled hole in the fender relocation bracket and secure to the fender and inner fender using the

saved **OE** bolt from the inner fender support bracket. See ILLUSTRATION 19.

95. Drill three holes through the inner fender and fender relocation bracket using a **#27- .142"** drill bit.

**NOTE: Be sure the holes are centered and evenly spaced on the relocation bracket. SEE ILLUSTRATION 19.**

96. Secure the inner fender to the front fender relocation bracket (**90-3575 drvr** and **90-3576 pass**) bracket using the supplied **#8 X 3/4"** hardware from pack (**90-6517**). See ILLUSTRATION 19.

97. With the front wheels installed cycle the steering from lock to lock to check to make sure the front wheels have enough clearance in the wheel well. If the wheel contacts the front or rear of the wheel well additional trimming will be necessary.

**NOTE: Remove OE rotor/drum retaining clips from wheel studs before installing the wheels.**

98. Repeat on the remaining side of the vehicle.

99. On both sides of the vehicle, check the routing of the brake lines and the ABS wire harnesses. There must be no pinching, rubbing, or stretching of either component. Use zip ties to secure these items to the steering components. At full droop, cycle the steering from lock to lock while observing the reaction of these components. Check the caliper banjo fitting to ensure the line has the proper amount of slack. Reposition them if needed.

100. Lower the vehicle to the ground. Torque the lug nuts according to the wheel manufacturers recommendations.

101. With the truck on the ground torque the lower A-arm bolts according to the torque chart on page 23.

102. Center the steering wheel and lock it in place. Set the toe by adjusting the tie rod ends properly.  
**IMPORTANT!: If the steering wheel is not centered properly it will trigger the anti-lock brake and traction control warning lights.**

103. Recheck all hardware for proper installation and torque at this time.

**IMPORTANT! BE SURE TO BRING THE VEHICLE IMMEDIATELY TO A REPUTABLE ALIGNMENT SHOP.**

## REAR INSTALLATION:

1. Raise the rear of the vehicle enough for the tires to clear the ground and use jack stands on the frame to support the truck. Remove the rear tires and wheels.
2. Support the differential with your floor jack and remove the **OE** shock absorbers. It may be necessary to raise the differential housing slightly to facilitate their removal.
3. Completely remove the sway bar links from both ends of the sway bar. Save the fasteners.
4. Remove the **OE** bolts from the differential track bar at the upper track bar mount. Save this hardware.
5. Remove the brake line mount bolt at the upper front location of the vehicle gas tank. See ILLUSTRATION 21.
6. Carefully lower the differential away from the vehicle and remove the stock springs.

**IMPORTANT!:** *Be very careful not to damage the brake lines! Remove mounting brackets as needed to allow the brake lines freedom of movement sufficient to avoid damage. Remember to reinstall them when done.*

7. At the **OE** bump stop, measure from the center of the existing hole at the rear **2.800"** toward the front of the vehicle and carefully mark and center punch this location. Keep

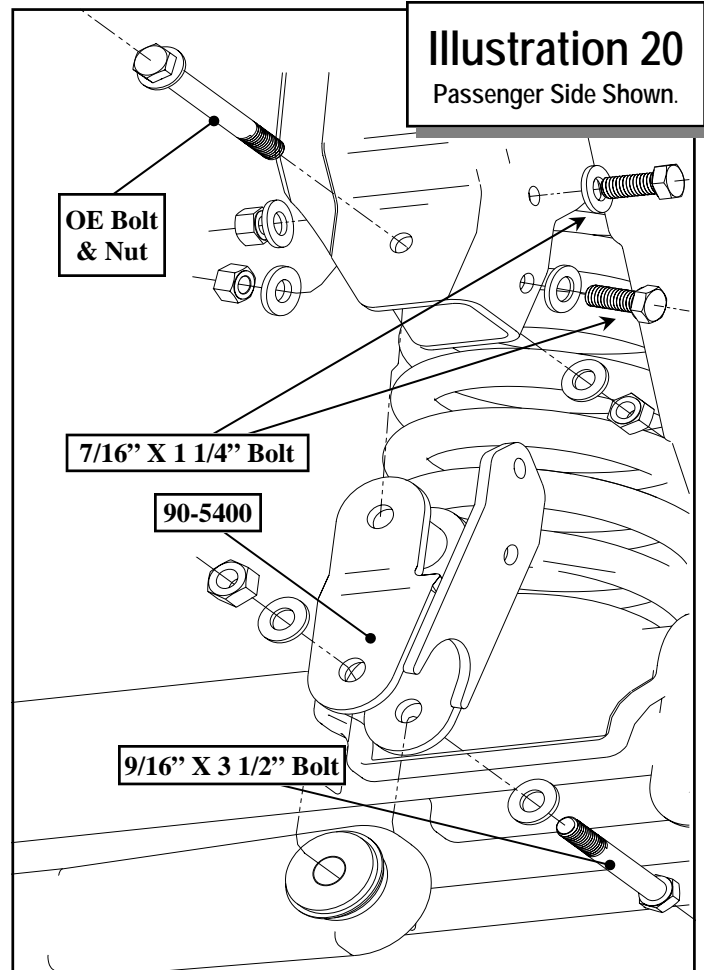
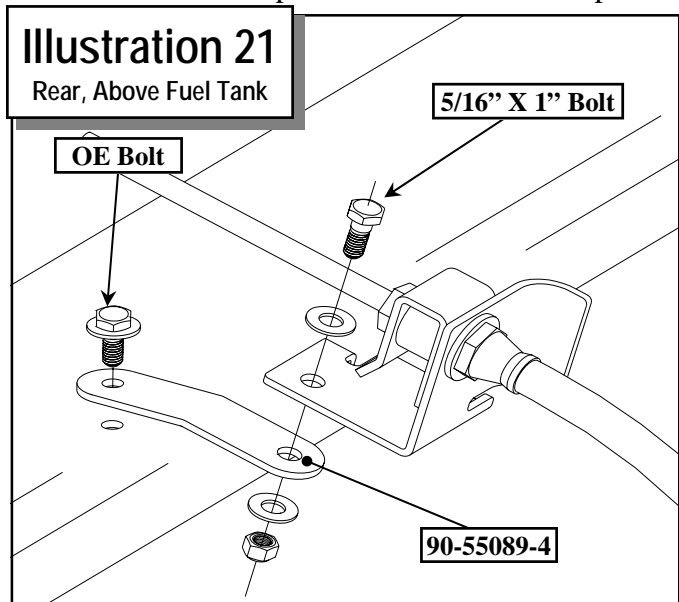

the center line between the two holes, parallel to the vehicle center line. Drill through this location with a **1/2"** drill bit. See ILLUSTRATION 22.

8. Using ILLUSTRATION 22 as a guide, install the bump stop extension plates (**90-3146**) to the existing bump stop by first installing one **3/8\" X 1"** bolt and lock washer through one of the holes in the bump stop extension. Slide the nut plate (**90-1702**) between the **OE** bump stop and the lower trailing arm until the back nut lines up with the hole in the **OE** bump stop. Take the bump stop extension with its bolt and place it on top of the pad and start the bolt into the nut plate. Rotate the nut plate to the location of the previously drilled front hole and start the second **3/8\" X 1"** bolt with lock washer into the remaining nut on the nut plate. Tighten these bolts to 45 ft-lbs

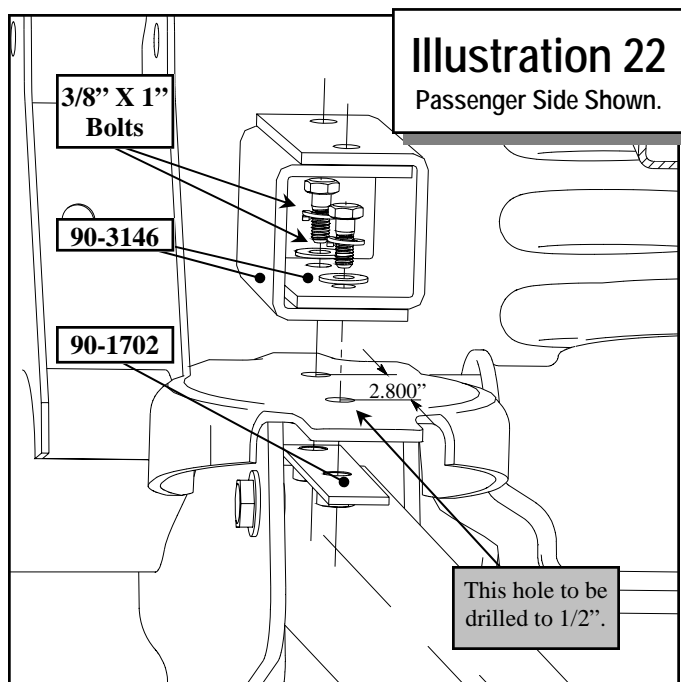

9. Repeat this procedure on the remaining side of the vehicle.
10. On the rear of the drivers side frame rail, loosen and disconnect the parking brake adjuster cable connector and nut. Compress the retaining fingers on the rear cables and pull the parking break cables away from the frame.  
**NOTE: Mark the upper and lower cables so they can be put back in the same orientation.**
11. Remove the nuts and bolts attaching the upper and lower rear control arms on the driver's side of the frame. Do not remove the control arms from the passenger side.  
**NOTE: You may have to unbolt and pull back the lower front portion of the rear wheel well to access the upper control arm bolt.**
12. Loosen the bolt attaching the lower control arm to the axle bracket. Allow the lower control arm to hang downward.
13. Attach the control arm drop bracket (**90-1785 drv** and **90-1790 pass**) to the frame using the original bolts. See ILLUSTRATION 26.
14. Drill a **1/2"** hole through the bottom of the lower frame bracket hole and the frame. Install the **1/2"** hardware from hardware pack

(**90-6276**).

15. Tighten the **1/2"** nut and bolt to 65 ft-lbs and the original bolts to 80 ft-lbs.
16. Pull the parking brake cables through the new control arm drop bracket, the top cable through the bracket and the bottom cable through the hole in the side of the bracket. Connect the parking brake cable connector and nut. Adjust parking brake tension to factory specifications.
17. Loosely attach the upper control arm to the control arm drop bracket with the **9/16" X 3 1/2"** bolt, washer and nut from hardware pack (**90-6276**).  
**NOTE: Do not tighten the pivot bolts until the vehicle is at its new ride height.**
18. Loosely attach the lower control arm to the control arm drop bracket with the **9/16" X 4"** bolt, washer and nut from hardware pack (**90-6276**).  
**NOTE: Do not tighten the pivot bolts until the vehicle is at its new ride height. See ILLUSTRATION 26.**
19. Repeat the control arm drop bracket installation on the remaining side of the vehicle.
20. Compress the new spring with a coil spring compressor.
21. Continue to lower the differential until enough space exists to install the new Pro

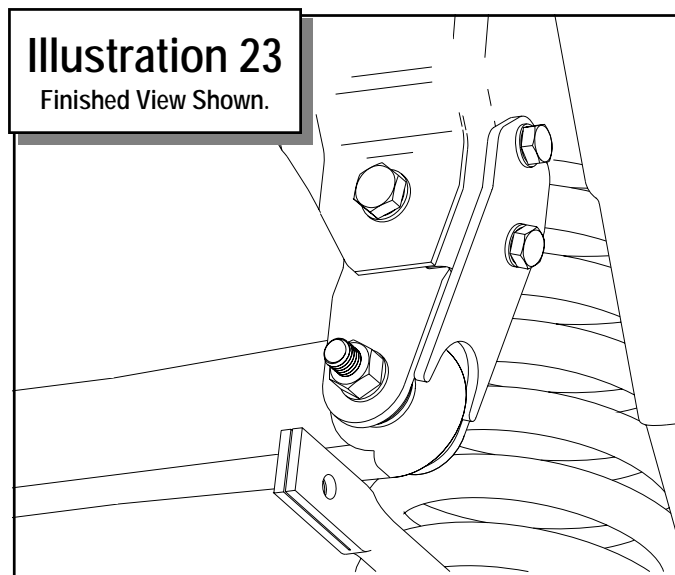

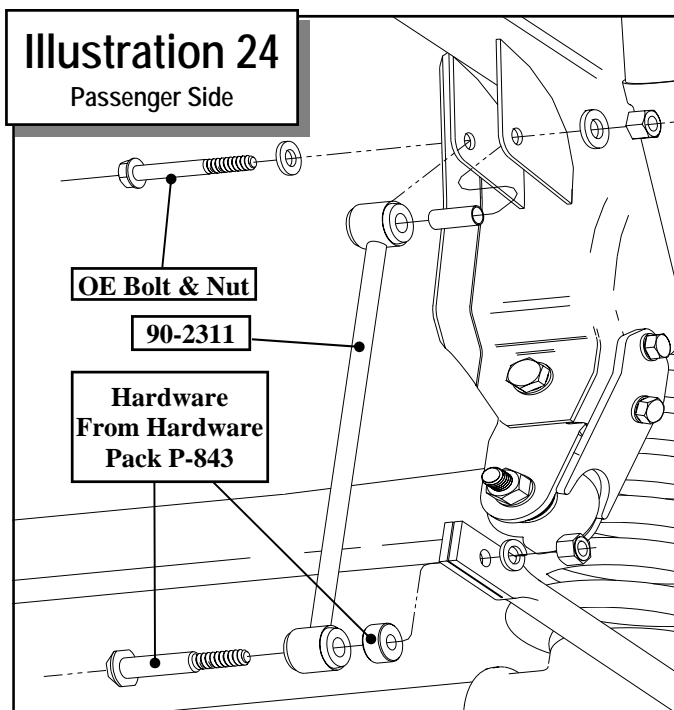

Comp springs, PN 14157.

**NOTE:** If the factory spring has a rubber pad remove it and install it on to the new spring.

22. You may have to release some slack in the differential vent hose by lightly pulling the excess down from the frame.
23. Repeat this procedure on the remaining side of the vehicle.
24. Raise the rear end until the new Pro Comp shock absorbers, (927543 or MX6105), can be installed. Ensure that the new springs are seated properly.
25. Using the OE bolt, install the brake line relocation bracket (90-55089-4) to the OE brake line mount position as shown in ILLUSTRATION 21. Bolt the OE bracket to the new relocation bracket using the 5/16" X 1" bolt, nut, and washer provided.
26. Using ILLUSTRATION 20 as a reference, install the track bar relocation adapter (90-5400). Place the adapter into the OE mount and use the OE bolt to hold it in place. On the passen-

ger side of the adapter are two holes that are used as drill guides for a 7/16" drill. Drill completely through the OE mount and install the 7/16" X 1 1/4" bolts, nuts, and washers provided. Torque these bolts to the bolt specifications in the rear of this manual.

27. Install the track bar into the newly installed adapter using the provided 9/16" X 3 1/2" bolt, nut and washer. Torque these bolts to the bolt specifications in the rear of this manual.
28. Install the sway bar using the new end links (90-2311). Use the bushings and sleeves from (90-6235). Use the OE bolt and nut on the top and use the hardware from pack (P-843) on the bottom. Torque these bolts to the bolt specifications in the rear of this manual. See ILLUSTRATION 24.
29. Torque all fasteners.
30. Install your wheels and tires, then lower the vehicle to the ground.  
**NOTE:** Remove OE rotor/drum retaining clips from wheel studs before installing the wheels.
31. With the vehicle on the ground and Tighten control arm bolts to OE specifications.

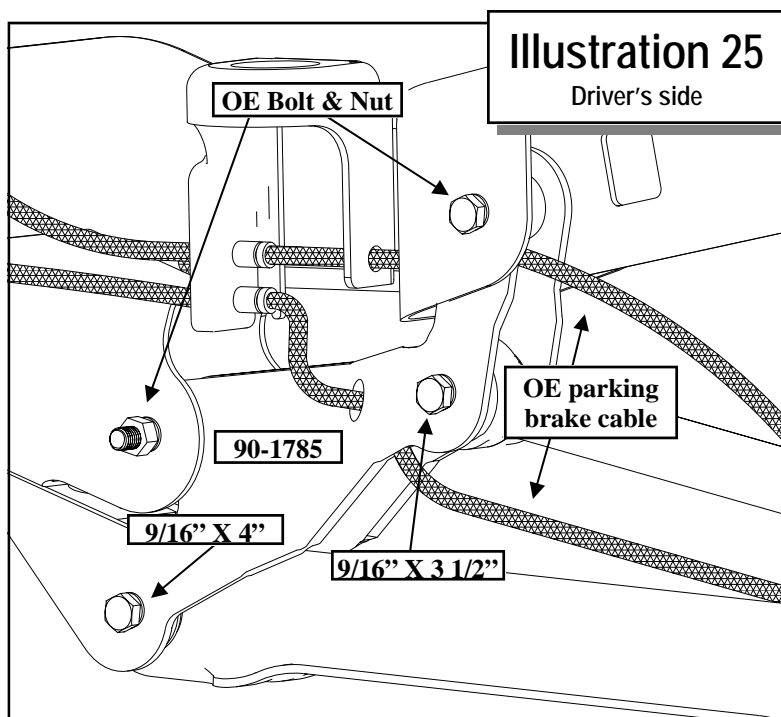

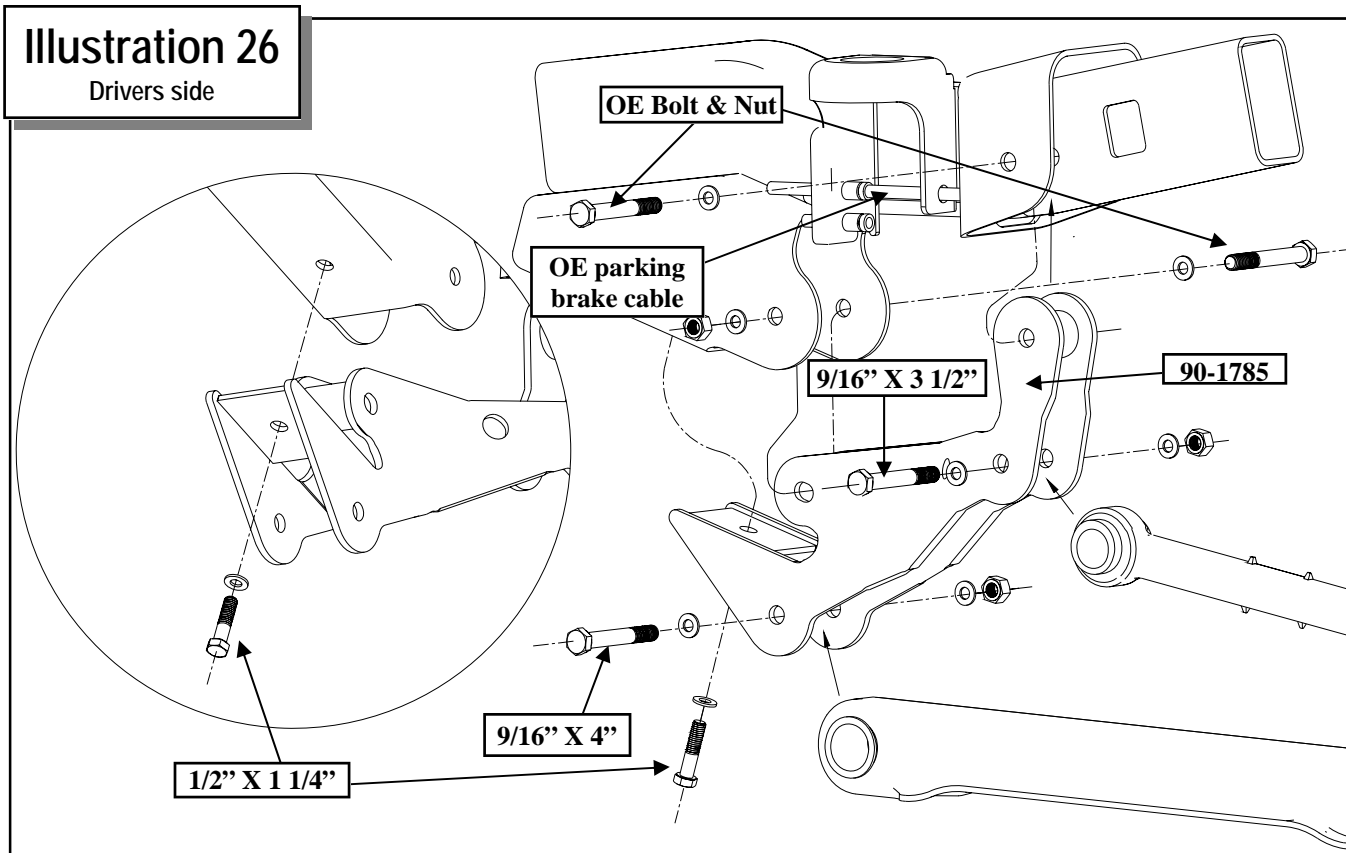

32. After installation is complete, double check that all nuts and bolts in the front and rear are tight. Refer to the chart at the end of this document for torque specifications. Unless otherwise directed, use this chart for all torque specs.

### Final notes:

1. If new tires are installed that are more than 10% taller than original tires, the speedometer must be recalibrated for the rear wheel anti-lock brake system to function properly. Contact an authorized GM dealer for details on recalibration.
2. With vehicle on the floor, cycle the steering from lock to lock and inspect the steering, suspension and driveline systems for proper operation, tightness and adequate clearance. Recheck brake hose/fittings for leaks. Be sure all brake lines are long enough for safe operation.
3. Have headlights readjusted to the proper settings.
4. Realign front end to factory specifications. Be sure the vehicle is at the desired ride height prior to realignment.
5. Recheck ALL fasteners at 100 miles to make sure they have not come loose. Due to the additional wear and tear created by larger tires and wheels, we recommend that you periodically check the suspension system and steering components to ensure service life and safe vehicle operation.

## Bolt Torque and ID

### Decimal System

### Metric System

All Torques in Ft. Lbs.

Bolt Size	Grade 5	Grade 8	Bolt Size	Class 9.8	Class 10.9	Class 12.9
5/16	15	20	M6	5	9	12
3/8	30	45	M8	18	23	27
7/16	45	60	M10	32	45	50
1/2	65	90	M12	55	75	90
9/16	95	130	M14	85	120	145
5/8	135	175	M16	130	165	210
3/4	185	280	M18	170	240	290

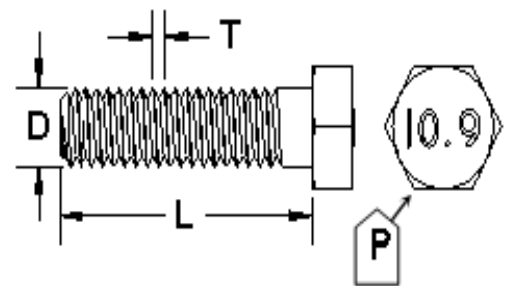
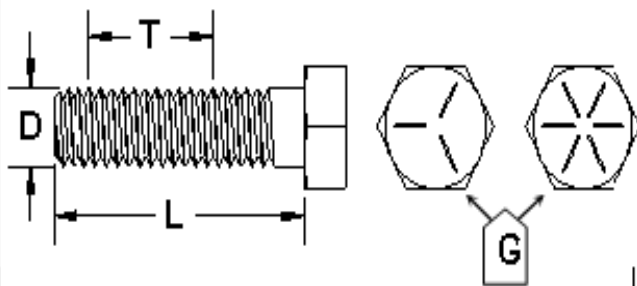

1/2-13x1.75 HHCS

Grade 5    Grade 8  
(No. of Marks + 2)

M12-1.25x50 HHCS



G = Grade (Bolt Strength)  
D = Nominal Diameter (Inches)  
T = Thread Count (Threads per Inch)  
L = Length (Inches)  
X = Description (Hex Head Cap Screw)

P = Property Class (Bolt Strength)  
D = Nominal Diameter (Millimeters)  
T = Thread Pitch (Thread Width, mm)  
L = Length (Millimeters)  
X = Description (Hex Head Cap Screw)

**Notice to Owner operator, Dealer and Installer:**

Vehicles that have been enhanced for off-road performance often have unique handling characteristics due to the higher center of gravity and larger tires. This vehicle may handle, react and stop differently than many passenger cars or unmodified vehicles, both on and off-road. You must drive your vehicle safely! Extreme care should always be taken to prevent vehicle rollover or loss of control, which can result in serious injury or even death. Always avoid sudden sharp turns or abrupt maneuvers and allow more time and distance for braking! Pro Comp reminds you to fasten your seat belts at all times and reduce speed! We will gladly answer any questions concerning the design, function, maintenance and correct use of our products.

**Please make sure your Dealer/Installer explains and delivers all warning notices, warranty forms and instruction sheets included with Pro Comp product.**

Application listings in this catalog have been carefully fit checked for each model and year denoted. However, Pro Comp reserves the right to update as necessary, without notice, and will not be held responsible for misprints, changes or variations made by vehicle manufacturers. Please call when in question regarding new model year, vehicles not listed by specific body or chassis styles or vehicles not originally distributed in the USA.

**Please note that certain mechanical aspects of any suspension lift product may accelerate ordinary wear of original equipment components.** Further, installation of certain Pro Comp products may void the vehicle's factory warranty as it pertains to certain covered parts; it is the consumer's responsibility to check with their local dealer for warranty coverage before installation of the lift.

**Warranty and Return policy:**

Pro Comp warrants its full line of products to be free from defects in workmanship and materials. Pro Comp's obligation under this warranty is limited to repair or replacement, at Pro Comp's option, of the defective product. Any and all costs of removal, installation, freight or incidental or consequential damages are expressly excluded from this warranty. Pro Comp is not responsible for damages and / or warranty of other vehicle parts related or non-related to the installation of Pro Comp product. A consumer who makes the decision to modify his vehicle with aftermarket components of any kind will assume all risk and responsibility for potential damages incurred as a result of their chosen modifications. Warranty coverage does not include consumer opinions regarding ride comfort, fitment and design. Warranty claims can be made directly with Pro Comp or at any factory authorized Pro Comp dealer.

**IMPORTANT!** To validate the warranty on this purchase please be sure to mail in the warranty card.

**Claims not covered under warranty-**

- Parts subject to normal wear, this includes bushings, bump stops, ball joints, tie rod ends and heim joints
  - Discontinued products at Pro Comp's discretion
- Bent or dented product
- Finish after 90 days
- Leaf or coil springs used without proper bump stops
- Light bulbs
- Products with evident damage caused by abrasion or contact with other items
- Damage caused as a result of not following recommendations or requirements called out in the installation manuals
- Products used in applications other than listed in Pro Comp's catalog
- Components or accessories used in conjunction with other manufacturer's systems
- Tire & Wheel Warranty as per Pro Competition Tire Company policy
- Warranty claims without "Proof of Purchase"
- Pro Comp Pro Runner coil over shocks are considered a serviceable shock with a one-year warranty against leakage only. Rebuild service and replacement parts will be available and sold separately by Pro Comp. Contact Pro Comp for specific service charges.
- Pro Comp accepts no responsibility for any altered product, improper installation, lack of or improper maintenance, or improper use of our products.

E-Mail: [tech@explorerprocomp.com](mailto:tech@explorerprocomp.com)  
Website: [www.explorerprocomp.com](http://www.explorerprocomp.com)  
Fax: (619) 216-1474  
Ph: (619) 216-1444

<b>PLACE</b>
<b><u>WARRANTY REGISTRATION</u></b>
<b><u>NUMBER</u></b>
<b>HERE:</b> _____