

2360 Boswell Road
Chula Vista, CA 91914
Phone 619.216.1444
Fax 619.216.1474
E-Mail tech@explorerprocomp.com



PRO COMP SUSPENSION

Suspension Systems that Work!

**Part # 52614
(Formerly 52604)
2000-2004
2WD Excursion**

This document contains very important information that includes warranty information and instructions for resolving problems you may encounter. Please keep it in the vehicle as a permanent record.

**** INSTALLATION REQUIRES A NEW PITMAN ARM. PRODUCTION DATE PRIOR TO APRIL 1ST, 1999 USE PART# FD400. AFTER APRIL 1ST, 1999 USE PART# FD600. ****

BILL OF MATERIALS

BOX 1 OF 3

<u>ITEM#</u>	<u>DESCRIPTION</u>	<u>QTY.</u>	<u>ILLUST.</u>
90-1245	Driver I-Beam Pivot Bracket	1	3
90-1248	Passenger I-Beam Pivot Bracket	1	2
90-1240	Driver Radius Arm Drop	1	1
90-1241	Passenger Radius Arm Drop	1	1
90-2120	Pivot Strut	1	3
90-6095	Spacer Packet	1	1
90-1051	Spacers	2	1
90-6150	Hardware Packet	1	
70-0563501800	9/16" x 3-1/2" USS Gr. 8 HCS Yellow	2	2, 3
70-0501251800	1/2" x 1-1/4" USS Gr. 8 HCS Yellow	3	3
70-0502751800	1/2" x 2-3/4" USS Gr. 8 HCS Yellow	1	3
73-05600034	9/16" SAE Hardened Flat Washer Yellow	4	2, 3
73-05000034	1/2" SAE Hardened Flat Washer Yellow	8	3
72-05600100516	9/16" USS Gr. 8 Stover Nut Zinc	2	2, 3
72-05000100816	1/2" USS Gr. 8 Stover Nut Zinc	4	3
90-2117	Sway Bar Support	1	5
90-6151	Hardware Packet	1	
70-0431251800	7/16" x 1-1/4" USS Gr. 8 HCS Yellow	14	2, 5
70-0311001802	5/16" x 1" USS Allen Cap Screw Black Alloy	2	4
73-04300034	7/16" SAE Hardened Flat Washer F436 Yellow	28	2, 5
73-03100030	5/16" SAE Flat Washer Zinc	4	4
72-04300100816	7/16" USS Gr. 8 Stover Lock Nut Grade C Zinc	14	2, 5
72-03100100512	5/16" USS Nyloc Nut Zinc	2	4

BOX 2 OF 3

<u>ITEM#</u>	<u>DESCRIPTION</u>	<u>QTY.</u>	<u>ILLUST.</u>
90-1859	Sway Bar Drop	2	5
90-2144	Bumpstop Spacers	2	4
13-90256	5/8" x 3.3" x 12.6" U-Bolt	4	
20-65471	Hardware Packet - 5/8" Nut & Washers	1	
90-6153	Bar Pin Packet	1	
55268	3" Shock Bar Pin (Rear Shock)	2	
99-250	2.5 Degree Shim	2	

BOX 3 OF 3

921510	ES9000 Shock Front	2
929508	ES9000 Shock Rear	2

**** ADDITIONAL PARTS REQUIRED MUST BE PURCHASED SEPARATELY ****

<u>ITEM#</u>	<u>DESCRIPTION</u>	<u>QTY.</u>	<u>ILLUST.</u>
22415	Rear Leaf Spring	2	
<u>ITEM#</u>	<u>DESCRIPTION</u>	<u>QTY.</u>	
24614	OR Coils Gasoline Engine	1	
24615	Coils Diesel Engine	1	
FD400	OR Pitman Arm Before April 1st, 1999 Production	1	
FD600	Pitman Arm After April 1st, 1999 Production	1	

Optional Equipment Available from your Pro Comp Distributor!

**LIGHTS
LIGHT BARS
TRACTION BARS
STEERING STABILIZERS
CAM BOLT KIT: #594**

Also, check out our outstanding selection of Pro Comp tires
compliment your new installation!

**PRO-COMP NOW OFFERS A FULL LINE OF ALL TERRAIN AND MUD TERRAIN TIRES.
CONTACT DEALER FOR DETAILS.**

PLEASE NOTE: Due to differences in manufacturing, dimensions and inflated measurements, tire and wheel combinations should be test fit prior to installation. Tire and wheel choice is crucial in assuring proper fit, performance, and the safety of your Pro Comp equipped vehicle. For this application, we recommend a wheel not to exceed 8" in width with a minimum backspacing of 4" must be used, additionally, a quality tire of radial design, not exceeding 35" tall X 12.5" wide is also recommended. Please note that the use of a 35" X 12.5" tire may require fender modification. Violation of these recommendations will not be endorsed as acceptable by Pro Comp Suspension and will void any and all warranties either written or implied.

BEFORE YOU BEGIN:

- Installation requires a professional mechanic.

- Prior to installation, carefully inspect the vehicle's steering and drive train systems, paying close attention to the tie rod ends, pitman and idler arms, ball joints and wheel bearings. Also check steering-to-frame and suspension-to-frame attaching points for stress cracks. The overall vehicle must be in excellent working condition; repair or replace worn parts.

- Read instructions carefully and study the illustrations before attempting installation.

- Check the parts and hardware against the parts list to assure that your kit is complete. Separating parts according to the areas where they will be used and placing the hardware with the brackets before you begin will save installation time.

- Secure and properly block vehicle prior to beginning installation.

- Always wear safety glasses when using power tools.

- Use caution when cutting is required under the vehicle; the factory undercoating is flammable. Take usual fire precautions.

- Foot pound torque readings are listed on the Torque Specifications Chart at the end of the instructions unless specifically stated in an instruction. Apply loctite retaining compound where specified.

FRONT INSTALLATION INSTRUCTIONS:

1) Park vehicle on a flat hard surface (i.e. asphalt or concrete). Set parking brake and block both rear wheels in front and behind tires.

2) Measure and record the distance from the center of each wheel to the top of its fender opening. Record below.

LF: _____ RF _____
LR: _____ RR: _____

- 3) Raise the front of the vehicle with a floor jack and support with jack stands behind the radius arm mounts. **(Never work on a vehicle while it is on the floor jack and unsupported by jack stands).**
- 4) Remove front tires. Remove sway bar links at the sway bar. Remove sway bar mounting bolts and lower sway bar. Remove nut clips from frame. Retain all hardware (It will be reused).
- 5) Raise driver I-Beam enough to relieve tension on the shock hardware. Remove the lower shock bolt. Remove the upper coil clip and the lower coil retaining nut. Lower beam enough to remove the coil. Raise the beam and reinstall the lower shock bolt. The stock shock will limit the down travel during installation of the brackets.

*** * REPEAT STEP 5 ON PASSENGER SIDE * ***

- 6) Remove the small draglink end at steering box with a tie rod separating tool. Use a pitman arm puller and remove pitman arm. When installing your new pitman arm you will need to first measure the sector shaft coming out of the steering box. If the diameter of the sector shaft above the splines is 1.3125 inches install the **FD 400** pitman arm. If the diameter of the sector shaft above the splines is 1.375 inches install the **FD 600** pitman arm. Install the pitman arm and hand tighten sector shaft nut then tighten only with a torque wrench. Torque sector shaft nut to 200 ft. lbs. install draglink end into pitman arm and torque draglink nut to 60 ft. lbs. Reinstall cotter pin.
- 7) Remove passenger radius arm pivot bolt at the bracket. Remove the hardware securing the bracket to the frame and remove bracket.
- 8) Install **90-1241** radius arm bracket and spacer using the factory hardware. (See **Illustration 1**) Torque mounting hardware to 65 ft. lbs.

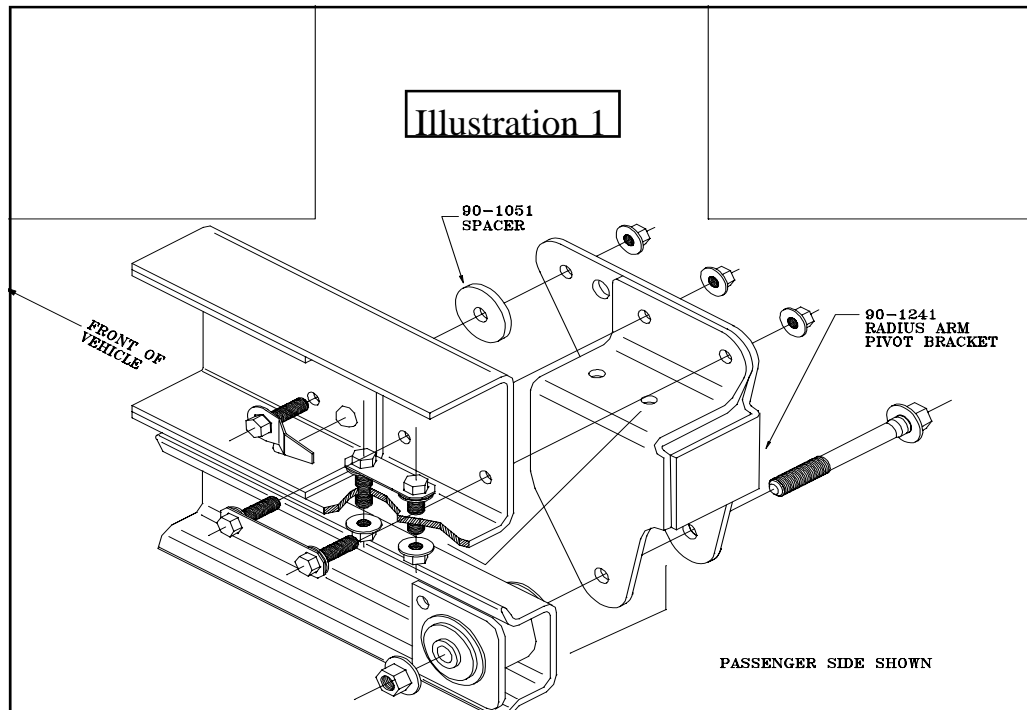

9) Install radius arm into bracket and install pivot bolt. It will be necessary to raise the I-Beam to align the bolt holes in the bracket with the radius arm sleeve. **DO NOT TIGHTEN PIVOT BOLT AT THIS TIME.**

**** REPEAT STEPS 7 - 9 ON DRIVER SIDE ****

NOTE: On Driver side it may be necessary to remove ABS servo and secure out of the work area in order to remove and install Radius arm bracket hardware.

10) Remove I-Beam pivot bolts on both sides. Raise or lower the I-Beams to remove the bolts without damaging the threads.

11) Remove the I-Beam pivot brackets from the crossmember. Make note of hardware location. All hardware will be reinstalled in the hole it was removed from.

12) Install the passenger I-Beam pivot bracket **90-1248** using the existing bolt plate and the **1/2" x 2-3/4"** bolt into the factory holes. **DO NOT TIGHTEN ANY HARDWARE.** (See **Illustration 2**)

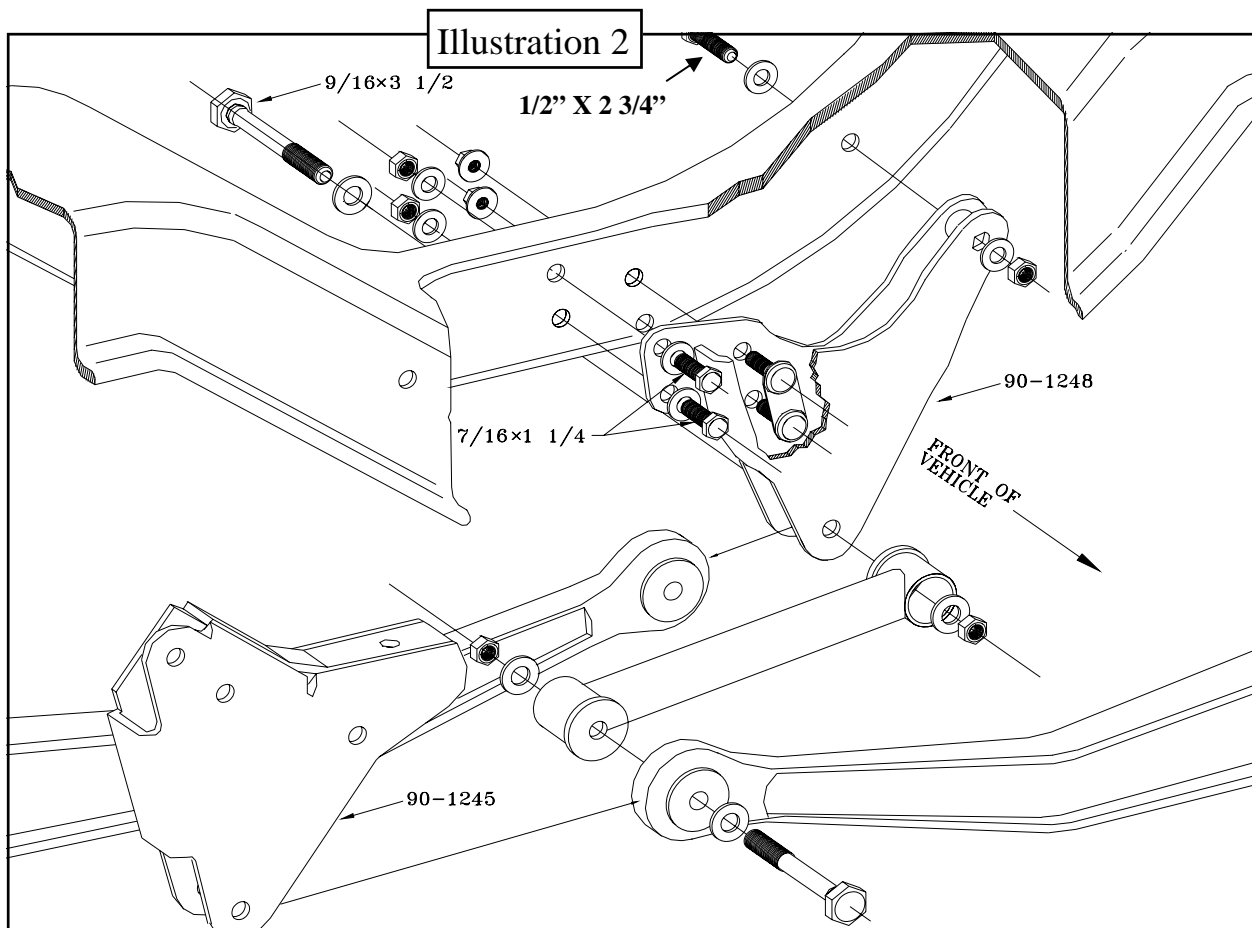

13) Install the driver I-Beam pivot bracket **90-1245** using the existing hardware. **DO NOT TIGHTEN ANY HARDWARE.** (See **Illustration 3**)

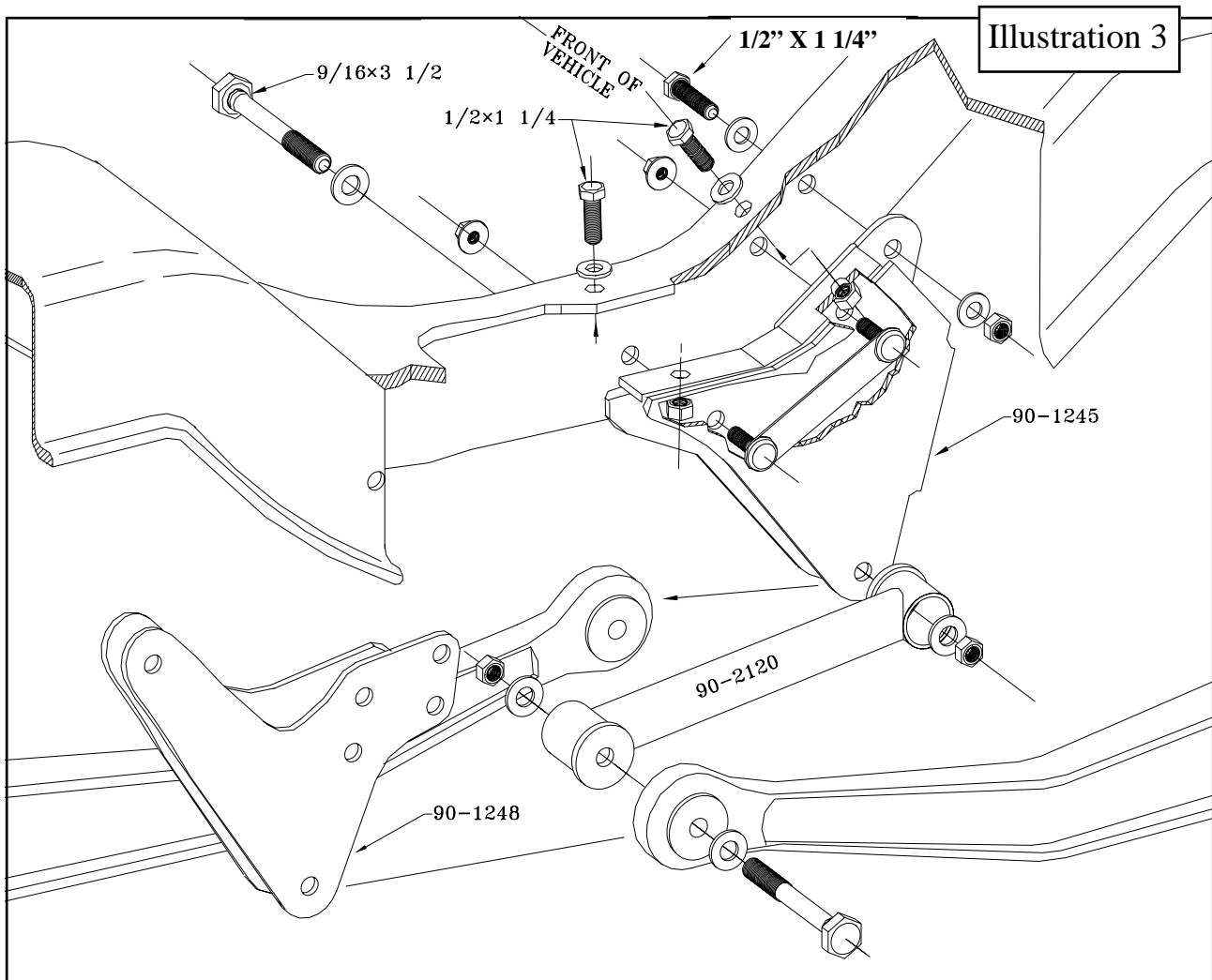

14) Install the pivot strut **90-2120** between the passenger and driver pivot brackets and hold it in place with the **9/16" x 3-1/2"** bolts provided. **DO NOT TIGHTEN ANY HARDWARE.**

15) Begin to tighten I-Beam pivot bracket hardware. Rotate back and forth from one bracket to the other one bolt at a time. This will position the pivot brackets in the proper location. If not properly located, the I-Beam pivot bolt will be in a bind and installation of the I-Beams and pivot strut will be difficult.

16) Once the pivot bracket hardware is tight, remove the **9/16"** bolts and the pivot strut. The bolts should remove with ease. If not, repeat Step #14, paying close attention to the location of the pivot brackets.

17) Use the two holes in the passenger pivot bracket for a drill template and drill the crossmember flange with a $7/16$ " drill. Install the $7/16$ " x $1-1/4$ " bolts and torque to 50 ft. lbs.

VERY IMPORTANT!: Use caution not to damage the oil pan!

18) Install I-Beams into pivot brackets and install pivot strut between brackets. Raising and or lowering I-Beam will help align holes. Torque $9/16$ " bolts to 105 ft. lbs.

19) Remove factory bumpstops and install the bumpstop spacers **90-2144**. (Illustration 4) Factory bolt and $5/16$ " allen bolt will be used.

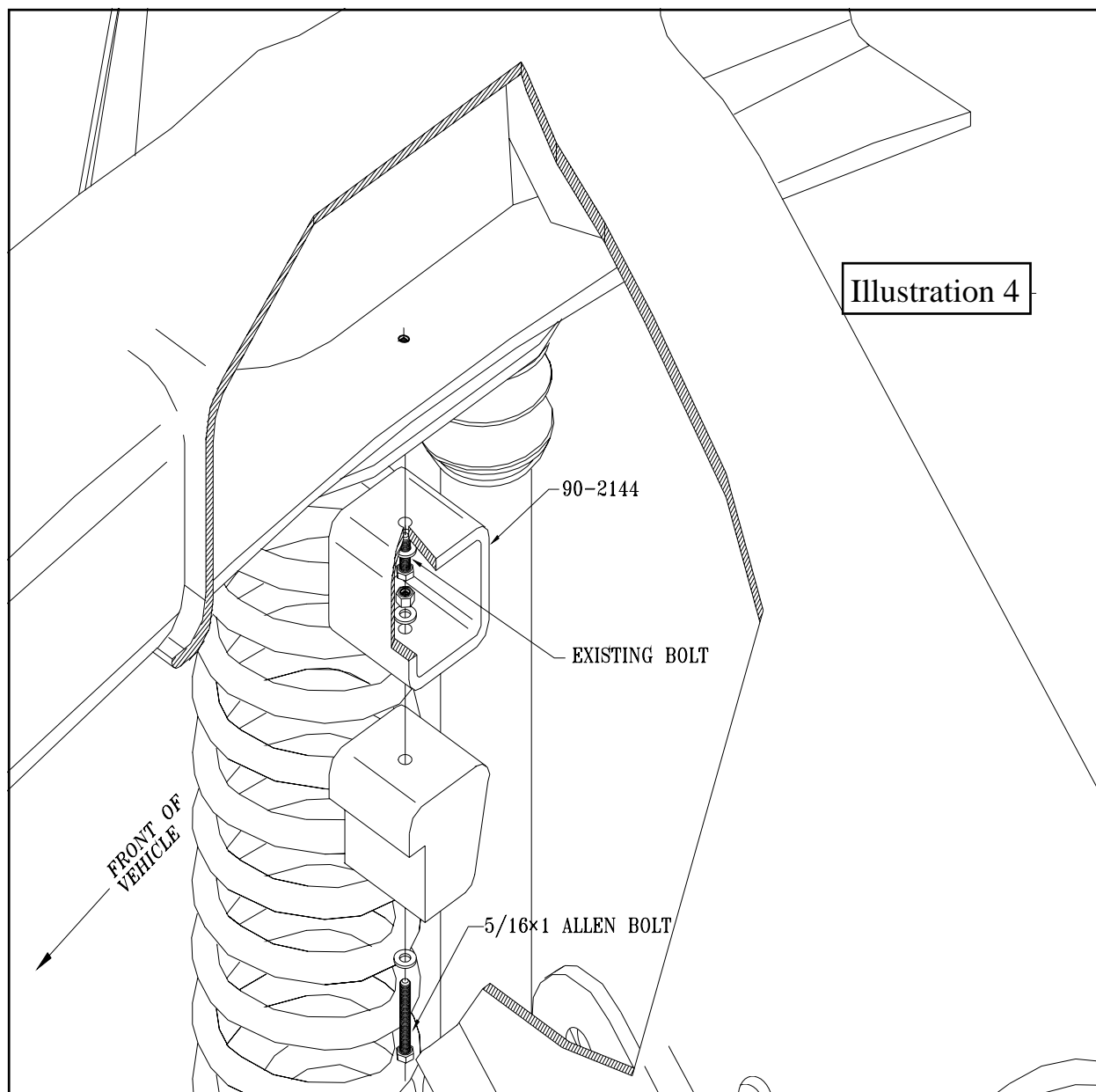

20) Install sway bar drop brackets **90-1859** and support tube **90-2117** as shown in **Illustration 5**. Assemble all components shown before you begin to tighten any hardware. Torque **7/16"** hardware to 50 ft. lbs.

NOTE: *It may be necessary to loosen the steering box to allow proper installation of the rear sway bar drop bolt on the driver side.*

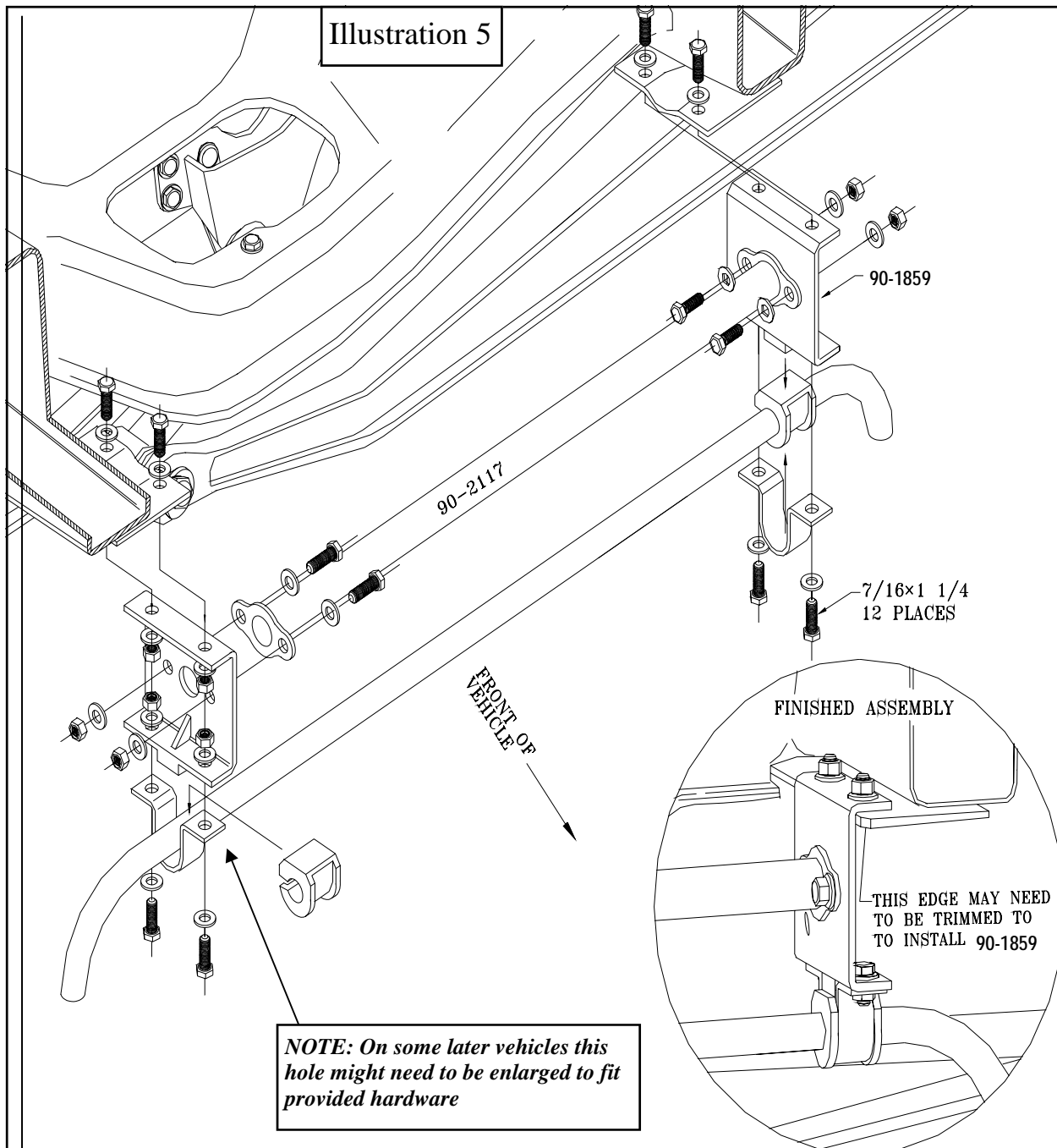

21) Raise driver I-Beam and remove shock absorber.

22) Lower I-Beam and install new coil. Raise I-Beam until it begins to compress coil and install the coil retaining hardware top and bottom.

23) Install new front shock **921510** and tighten hardware.

*** * REPEAT STEPS 21 - 23 ON OPPOSITE SIDE * ***

24) If installing optional cam kit (594) remove pinch bolt. Remove cam from driver side I-beam and slide in new eccentric cam. Replace pinch bolt. Do not tighten at this time. Repeat on remaining side of vehicle. Turn the wheel full lock to the left and grind the visible backs of the spindles around the ball joint removing approximately 3/16". Start at the top, tapering down to nothing at the bottom. Turn wheel to full lock the opposite way and grind the remaining, now visible, spindle area. (See **Illustration 6**)

NOTE: After grinding adjust each side to maximum camber and turn wheel lock to lock and make sure there is adequate spindle clearance.

25) Torque pinch bolt to factory specifications.

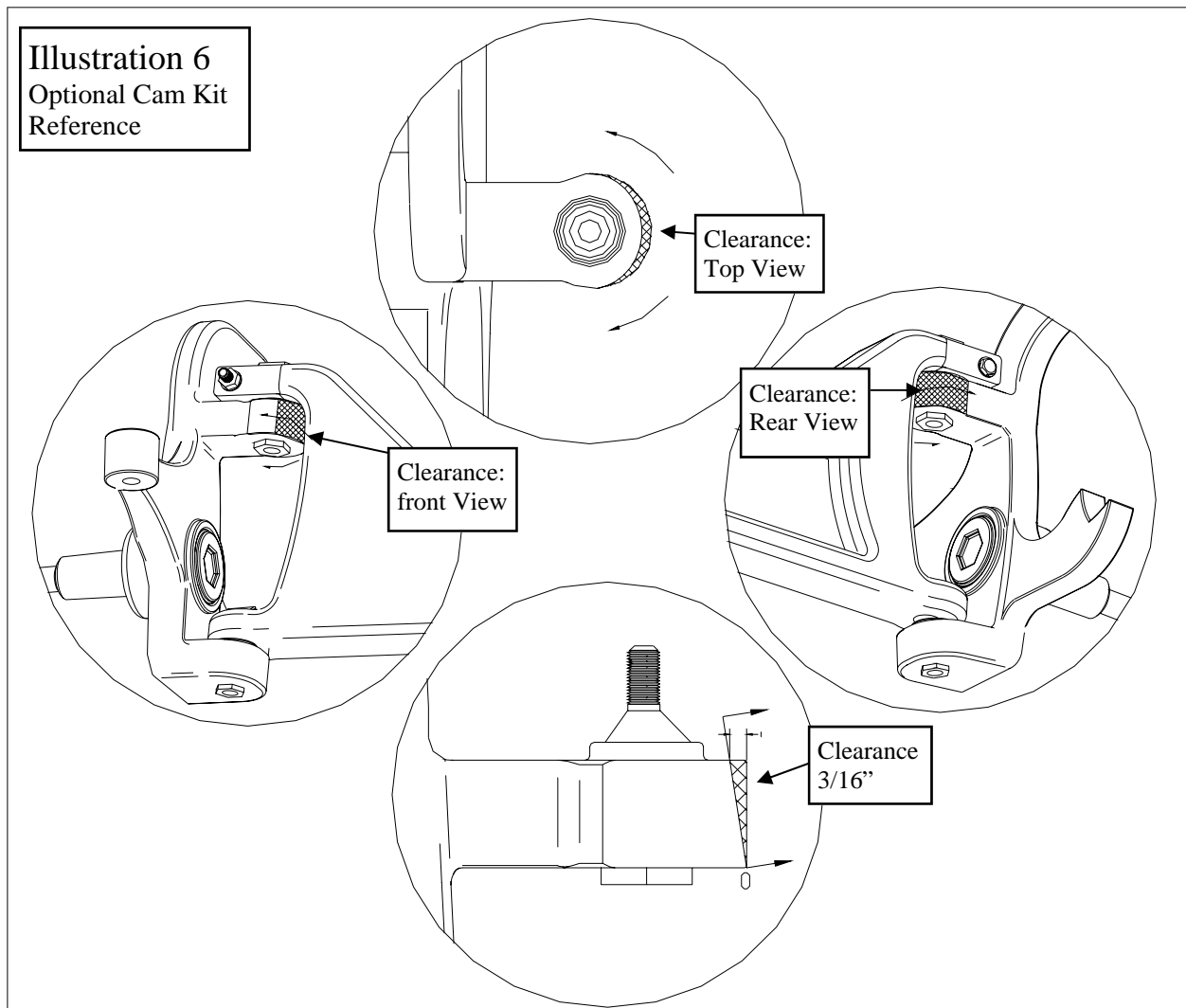

26) Replace front tires and set vehicle on ground. Connect sway bar links to sway bar and torque to 55 ft. lbs. Torque radius arm bolts to 105 ft. lbs.

27) Cycle steering full right to full left, checking for any steering linkage contact, spindle or brake line contact. Front brake lines should be of adequate length. However, the steel portion may need to be bent slightly to clear the larger tire.

REAR INSTALLATION:

- 1) Block both front wheels in front and behind tires.
- 2) Raise rear of vehicle with a floor jack and support with jack stands forward of the front spring hanger.
- 3) Remove tires and shock absorbers. It may be necessary to lift axle with a jack to unload shock and remove hardware.
- 4) Support the axle with floor jack and remove the U-bolts on the driver side. Lower axle until it clears the leaf springs.
- 5) Lower the rear axle and remove the factory rear leaf spring from the driver side only at this time.
- 6) Install the new Pro Comp spring pack (**PN 22415**) to the hangers using the factory hardware. Install U-bolts (**13-90256**) and hardware (**20-65471**). Do not tighten at this time.

*** * REPEAT STEPS 4 - 6 ON OPPOSITE SIDE * ***

- 7) Raise axle until the vehicle begins to lift off the jack stands. Torque U-bolts to 115 ft. lbs.

NOTE: If driveline vibrations occur under acceleration insert 2.5 degree shims (99-250) with the fat end of the taper facing toward the front of the vehicle in between the spring and the spring pocket on the rear end.

- 8) Install tires and lower vehicle to ground.

- 9) Torque the spring mounting bolts at this time. The 16mm bolts are torqued to 115 ft. lbs. and the 18mm bolts are torqued to 130 ft. lbs.

CHECKS AND ADJUSTMENTS:

- Check brake cables and emergency brake cable for pinching, rubbing or pulling. Adjust if necessary.
- Have front end aligned.
- Have head lights adjusted.
- Re-torque all hardware after first 100 miles.

Use this only as a guide for hardware without a called out torque specification in the instruction manual.

Bolt Torque and ID						
Decimal System			Metric System			
All Torques in Ft. Lbs. Maximums						
Bolt Size	Grade 5	Grade 8	Bolt Size	Class 9.8	Class 10.9	Class 12.9
5/16	15	20	M6	5	9	12
3/8	30	45	M8	18	23	27
7/16	45	60	M10	32	45	50
1/2	65	90	M12	55	75	90
9/16	95	130	M14	85	120	145
5/8	135	175	M16	130	165	210
3/4	185	280	M18	170	240	290

1/2-13x1.75 HHCS

D T L X

Grade 5 Grade 8
 (No. of Marks + 2)

M12-1.25x50 HHCS

D T L X

G = Grade (Bolt Strength)
 D = Nominal Diameter (Inches)
 T = Thread Count (Threads per Inch)
 L = Length (Inches)
 X = Description (Hex Head Cap Screw)

P = Property Class (Bolt Strength)
 D = Nominal Diameter (Millimeters)
 T = Thread Pitch (Thread Width, mm)
 L = Length (Millimeters)
 X = Description (Hex Head Cap Screw)

Notice to Owner operator, Dealer and Installer:

Vehicles that have been enhanced for off-road performance often have unique handling characteristics due to the higher center of gravity and larger tires. This vehicle may handle, react and stop differently than many passenger cars or unmodified vehicles, both on and off-road. You must drive your vehicle safely! Extreme care should always be taken to prevent vehicle rollover or loss of control, which can result in serious injury or even death. Always avoid sudden sharp turns or abrupt maneuvers and allow more time and distance for braking! Pro Comp reminds you to fasten your seat belts at all times and reduce speed! We will gladly answer any questions concerning the design, function, maintenance and correct use of our products.

Please make sure your Dealer/Installer explains and delivers all warning notices, warranty forms and instruction sheets included with Pro Comp product.

Application listings in this catalog have been carefully fit checked for each model and year denoted. However, Pro Comp reserves the right to update as necessary, without notice, and will not be held responsible for misprints, changes or variations made by vehicle manufacturers. Please call when in question regarding new model year, vehicles not listed by specific body or chassis styles or vehicles not originally distributed in the USA.

Please note that certain mechanical aspects of any suspension lift product may accelerate ordinary wear of original equipment components. Further, installation of certain Pro Comp products may void the vehicle's factory warranty as it pertains to certain covered parts; it is the consumer's responsibility to check with their local dealer for warranty coverage before installation of the lift.

Warranty and Return policy:

Pro Comp warrants its full line of products to be free from defects in workmanship and materials. Pro Comp's obligation under this warranty is limited to repair or replacement, at Pro Comp's option, of the defective product. Any and all costs of removal, installation, freight or incidental or consequential damages are expressly excluded from this warranty. Pro Comp is not responsible for damages and / or warranty of other vehicle parts related or non-related to the installation of Pro Comp product. A consumer who makes the decision to modify his vehicle with aftermarket components of any kind will assume all risk and responsibility for potential damages incurred as a result of their chosen modifications. Warranty coverage does not include consumer opinions regarding ride comfort, fitment and design. Warranty claims can be made directly with Pro Comp or at any factory authorized Pro Comp dealer.

IMPORTANT! To validate the warranty on this purchase please be sure to mail in the warranty card.

Claims not covered under warranty-

- Parts subject to normal wear, this includes bushings, bump stops, ball joints, tie rod ends and heim joints
 - Discontinued products at Pro Comp's discretion
- Bent or dented product
- Finish after 90 days
- Leaf or coil springs used without proper bump stops
- Light bulbs
- Products with evident damage caused by abrasion or contact with other items
- Damage caused as a result of not following recommendations or requirements called out in the installation manuals
- Products used in applications other than listed in Pro Comp's catalog
- Components or accessories used in conjunction with other manufacturer's systems
- Tire & Wheel Warranty as per Pro Competition Tire Company policy
- Warranty claims without "Proof of Purchase"
- Pro Comp Pro Runner coil over shocks are considered a serviceable shock with a one-year warranty against leakage only. Rebuild service and replacement parts will be available and sold separately by Pro Comp. Contact Pro Comp for specific service charges.
- Pro Comp accepts no responsibility for any altered product, improper installation, lack of or improper maintenance, or improper use of our products.

E-Mail: tech@explorerprocomp.com
Website: www.explorerprocomp.com
Fax: (619) 216-1474
Ph: (619) 216-1444

PLACE
WARRANTY REGISTRATION
NUMBER
HERE: _____