

2360 Boswell Road
Chula Vista, CA 91914
Phone 619.216.1444
Fax 619.216.1474
E-Mail tech@explorerprocomp.com



PRO COMP SUSPENSION

Suspension Systems that Work!

Part # 51022 - 6" Lift
1999-2006 Chevrolet / GMC
Tahoe / Yukon, 4 X 4
(- Includes Front Drive Shaft -)

WITHOUT Electronic Ride Control Option

NOTE: 2004 models with traction control and Borg Warner transfer case 4482 require pro comp driveshaft 51246 to be shortened by 1". Driveshaft modifications should only be performed by a certified driveline shop.

This document contains very important information that includes warranty information and instructions for resolving problems you may encounter. Please keep it in the vehicle as a permanent record.

Part #	Description	Qty.	Illus.	Page
90-1450	FRONT CROSS MEMBER	1	7	9
90-1496	SWAY BAR SPACER	2	10	11
90-2202	DIFFERENTIAL TORQUE TUBE	1	5	8
90-6158	HARDWARE PACK, CENTER LINK DROP	1		
90-2055	1/2" ID X 1 1/2" OD X 3/8" SPACER	2	7	9
90-2014	SPACER, 3/4" OD X 1/2" ID X 1/4"	2	8	10
90-4053	ROD END GUIDE	2	7, 8	9, 10
96-4036	STEERING CONE REDUCER	4	7	9
90-6170	HARDWARE PACK, UPPER A-ARM DROPS	1		
42-778T	CAM-BOLTS	4	13, 14	12
90-6173	HARDWARE PACK, FRONT	1		
70-0372251543	3/8" X 2 1/4" NC SOCKET HEAD CAP SCREW	4	10	11
73-03700034	3/8" SAE GR 8 FLAT WASHER	8		
72-03700100816	3/8" NC STOVER NUT	4		
70-0503751800	1/2" X 3 3/4" NC GR 8 HEX BOLT	2	7	9
73-05000038	1/2" GR 8 AN FLAT WASHER	10		
70-0624501800	5/8" X 4 1/2" NC GR 8 HEX BOLT	2	14	12
73-06200034	5/8" SAE GR 8 FLAT WASHER	4		
72-06200100816	5/8" NC STOVER NUT	2		
70-0502751800	1/2" X 2 3/4" NC GR 8 HEX BOLT	2	7	9
73-05000034	1/2" GR 8 FLAT WASHER	4		
72-05000100816	1/2" NC STOVER NUT	4		
90-6175	HARDWARE PACK, REAR A-ARM/DIFF DROP	1		
70-0625501800	5/8" X 5 1/2" NC GR 8 HEX BOLT	2	13	12
73-06200034	5/8" SAE GR 8 FLAT WASHER	4		
72-06200100816	5/8" NC STOVER NUT	2		
70-0371251800	3/8" X 1 1/4" NC GR 8 HEX BOLT	6	3	7
73-03700034	3/8" SAE GR 8 FLAT WASHER	14		
72-03700100816	3/8" NC STOVER NUT	6		
70-0561751800	9/16" X 1 1/2" NC GR 8 HEX BOLT	2	6	8
73-05600042	9/16" USS GR 8 FLAT WASHER	2		
73-05600034	9/16" SAE GR 8 FLAT WASHER	2		
72-05600100816	9/16" NC STOVER NUT	2		
72-03700100512	3/8" NC GR 5 NY-LOCK NUT	2	4	7
90-6234	HARDWARE PACK, COMPRESSION STRUT	1		
70-0501251800	1/2" X 1 1/4" NC GR 8 HEX BOLT	2	12	11
70-0504001800	1/2" X 4" NC GR 8 HEX BOLT	4	11, 12	11
72-050100816	1/2" NC STOVER NUT	4		
73-05000034	1/2" SAE GR 8 FLAT WASHER	10		
90-6236	HARDWARE PACK, TRACK BAR & TORSION DROP	1		
70-0563501800	9/16" X 3 1/2" NC GR 8 HEX BOLT	1	19	14
70-0563001800	9/16" X 3" NC GR 8 HEX BOLT	2	15	12
72-056100816	9/16" NC STOVER NUT	3		
73-05600034	9/16" SAE GR 8 FLAT WASHER	6		
70-0431251800	7/16" X 1 1/4" NC GR 8 HEX BOLT	2	19	14
72-043100816	7/16" NC STOVER NUT	2		
73-04300034	7/16" SAE GR 8 FLAT WASHER	4		
72-0311001800	5/16" X 1" NC GR 8 HEX BOLT	1	17	13
72-031100816	5/16" GR 8 STOVER NUT	1		
73-03100034	5/16" SAE GR 8 FLAT WASHER	2		
90-6181	HARDWARE PACK, SHOCK ADAPTER	1		
90-1079	SHOCK ADAPTER	2	16	12
54314	SHOCK SLEEVE, 1/2" X 5/8" X 1.480"	2	16	12
70-05000100512	1/2" X 2 3/4" GR 5 HEX BOLT	2	16	12
72-05000100512	1/2" GR 5 NY-LOCK NUT	2		
72-06200100512	5/8" GR 5 NY-LOCK NUT	2		
73-06200032	5/8" SAE GR 8 FLAT WASHER	2		
90-1785	REAR CONTROL ARM DROP BRACKET DRIVER	1		
90-1790	REAR CONTROL ARM DROP BRACKET PASSENGER	1		
90-6276	HARDWARE PACK, REAR CONTROL ARM DROP BRACKET	1		
70-0563501800	9/16"-12 X 3.5" GR 8 HEXBOLT	2		
70-0564001800	9/16"-12 X 4" GR 8 HEXBOLT	2		
72-056100816	9/16"-12 GR 8 STOVER NUT	4		
73-05600034	9/16" SAE HARDENED WASHER	8		
70-0501251800	1/2" X 1 1/4" GR 8 HEX BOLT	2		
72-050100816	1/2" GR 8 STOVER NUT	2		
73-05000034	1/2" GR 8 FLAT WASHER	4		
90-6303	HARDWARE PACK: FRONT BRAKE LINE	1		
90-1868	FRONT BRAKE LINE DROP	2		
90-6299	HARDWARE PACK	1		
90-6189	DIFF VENT	1		

Part #	Description	Qty.	Illus.	Page
Box 2 of 6-PN 51022-2				
90-1435	COMPRESSION STRUT MOUNT	2	12	11
90-1446	DIFFERENTIAL DROP, DRIVER SIDE	1	5	8
90-1447	DIFFERENTIAL DROP, PASSENGER SIDE	1	6	8
90-1455	UPPER A-ARM DROP, DRIVER SIDE	1		
90-1466	UPPER A-ARM DROP, PASSENGER SIDE	1	10	11
90-2196	CENTER STEERING LINK	1	7	9
96-1505	WELD PLATE	1	1	6
90-6172	HARDWARE PACK, UPPER A-ARM DROP	1		
70-0431251800	7/16" X 1 1/4" NC GR 8 HEX BOLT	4	10	11
73-04300034	7/16" SAE GR 8 FLAT WASHER	8		
72-04300100816	7/16" NC STOVER NUT	4		
70-0561501800	9/16" X 1 1/2" NC GR 8 HEX BOLT	4	10	11
70-0563751800	9/16" X 3 3/4" NC GR 8 HEX BOLT	1	5	8
73-05600034	9/16" SAE GR 8 FLAT WASHER	10		
72-05600100816	9/16" NC STOVER NUT	5		
70-0501251800	1/2" X 1 1/4" NC GR 8 HEX BOLT	1	5	8
73-05000034	1/2" SAE GR 8 FLAT WASHER	2		
90-6179	HARDWARE PACK, COMPRESSION STRUT	1		
15-11148	COMPRESSION STRUT BUSHING	8	11, 12	11
90-2109	COMPRESSION STRUT SLEEVE	4	11, 12	11
90-1476	NUT PLATE-1/2"	3	5, 12	8, 11
15-11018	LOW PROFILE BUMP STOP	2	4	7
90-6235	HARDWARE PACK, SWAY BAR / BRAKE LINE	1		
P-843	SHOCK HARDWARE	2	20	14
60859H	SHOCK SLEEVE	2	20	14
45359	BUSHING, 5/8" "HOURLASS", URETHANE	4	20	14
90-55089-4	REAR BRAKELINE EXTENSION	1	17	17

Box 3 of 6-PN 51022-3

90-1459	REAR CROSS MEMBER	1	3, 4, 14	7, 12
90-2126	COMPRESSION STRUT	2	13	11
90-1606	TORSION BAR DROP BRACKET	2	15	12
90-2311	SWAY BAR EXTENSIONS	2	20	14
90-1682	TRACK BAR RELOCATION BRACKET	1	19	14
90-6244	HARDWARE PACK, BUMPSTOP	1		
90-3146	BUMP STOP PLATES	4	18	14
90-1702	NUT PLATE	2	18	14
70-0371001800	3/8" X 1" GR 8 HEX BOLT	4	18	14
73-03700836	3/8" GR 8 SPLIT WASHER	4		
90-6275	HARDWARE PACK, WASHERS	1		
90-1784	WASHER- 1.650 X .620 X .042	8		

Box 4 of 6-PN 51022-4

14121	REAR COIL SPRINGS	2		
-------	-------------------	---	--	--

Box 5 of 6-PN 51022-5

920590	SHOCK ABSORBER, ES9000 FRONT	2		
927543	SHOCK ABSORBER, ES9000 REAR	2		

Box 6 of 6-PN 51022-6

90-4051	FRONT DRIVESHAFT	1		
---------	------------------	---	--	--

Introduction:

- ◆ This installation requires a professional mechanic!
- ◆ We recommend that you have access to a GM service manual for your vehicle to assist in the disassembly and reassembly of your vehicle. It contains a wealth of detailed information.
- ◆ Ensure that your work space is of adequate size and the work surface is level. Place the vehicle in neutral. Place your floor jack under the front cross member and raise vehicle. Place jack stands under the frame rails behind the front wheel wells and lower the frame onto the stands. Remove the jack and place the vehicle back in gear, set the emergency brake, and place blocks both in front and behind the rear wheels.
- ◆ Prior to installation, carefully inspect the vehicle's steering and driveline systems paying close attention to the tie rod ends, ball joints, wheel bearing preload, pitman and idler arm. Additionally, check steering-to-frame and suspension-to-frame attaching points for stress cracks. The overall vehicle must be in excellent working condition. Repair or replace all worn or damaged parts!
- ◆ Read the instructions carefully and study the illustrations before attempting installation! You may save yourself a lot of extra work.
- ◆ Check the parts and hardware against the parts list to assure that your kit is complete. Separating parts according to the areas where they will be used and placing the hardware with the brackets before you begin will save installation time.
- ◆ Check the special equipment list and ensure the availability of these tools.
- ◆ Secure and properly block vehicle prior to beginning installation.
- ◆ **ALWAYS** wear safety glasses when using power tools or working under the vehicle!
- ◆ Use caution when cutting is required under the vehicle. The factory undercoating is flammable. Take appropriate precautions. Have a fire extinguisher close at hand.
- ◆ Foot pound torque readings are listed on the Torque Specifications chart at the end of the instructions. These are to be used unless specifically directed otherwise. Apply Loctite® retaining compound where specified.
- ◆ *Please note that while every effort is made to ensure that the installation of your Pro Comp lift kit is a positive experience, variations in construction and assembly in the vehicle manufacturing process will virtually ensure that some parts may seem difficult to install. Additionally, the current trend in manufacturing of vehicles results in a frame that is highly flexible and may shift slightly on disassembly prior to installation. The use of pry bars and tapered punches for alignment is considered normal and usually does not indicate a faulty product. However, if you are uncertain about some aspect of the installation process, please feel free to call our tech support department at the number listed on the cover page. We do not recommend that you modify the Pro Comp parts in any way as this will void any warranty expressed or implied by the Pro Comp Suspension company.*

Please Note:

- ◆ Front end and headlight realignment is necessary.
- ◆ Speedometer and ABS recalibration will be necessary if larger tires (10% more than stock diameter) are installed
- ◆ This suspension system utilizes the stock torsion bars which normally afford the best ride quality. If, after kit is installed, ride or handling seems too "soft", heavier Gross Vehicle Weight Rating (GVWR) bars can be installed. GM offers various bars for up to 10,000 lbs. GVWR.
- ◆ **Due to differences in manufacturing, dimensions and inflated measurements, tire and wheel combinations should be test fit prior to installation.** Tire and wheel choice is crucial in assuring proper fit, performance, and the safety of your Pro Comp equipped vehicle. For this application, a wheel not to exceed 8" in width with a minimum backspacing of 4" must be used. Additionally, a quality tire of radial design, not exceeding 35" tall X 12.5" wide is recommended. Please note that the use of a 35" X 12.5" tire may require fender modification. Violation of these recommendations will not be endorsed as acceptable by Pro Comp Suspension and will void any and all warranties either written or implied.

Special Equipment

A special removal tool is required for safe removal and installation of the torsion adjuster arms. This special puller can be purchased from your local GM dealer (Tool #J36202) or from Kent Moore Tool Group in Roseville, MI. (800) 345-2233 or (313) 774-9500 (Part #J22517-C). You may be able to rent one of these at your local parts store. Please refer to your GM service manual for more information.

WARNING:

Be extremely careful when loading or unloading the torsion bars! There is a tremendous amount of stored energy in the bars. Keep your hands and body clear of the adjuster arm assembly and puller tool in case anything slips or breaks! Remember your safety glasses!

This kit requires a minor amount of welding. Make sure you have access to a welder *and* someone qualified to do the welding.

Torque specifications are provided on page 15

Front Installation:

1. If there are factory skid plates installed, remove them.
2. Measure the torsion bar adjusting screw depth and record this dimension for use when replacing the torsion adjuster arm on reassembly. Remove the torsion bar adjusting screw. Apply a small amount of lubricating grease to the puller (See note above) threads and the puller shaft-to-adjuster arm contact point. Load the puller and torsion adjuster arm until the adjuster nut can be easily removed from the cross member. Back the puller off to unload the torsion bar and set the puller aside. With the bar unloaded, slide it forward into the lower control arm until the adjuster arm falls free. If the bar seems stuck, use a hammer and punch through the hole in the rear of the cross member to dislodge it. Repeat this procedure on the other side of the vehicle.

Mark the orientation of both torsion bars (i.e., left side, right side, and front). They must be reinstalled exactly as removed!

3. Remove the torsion bar cross member by removing the through bolts on each side of the vehicle. With the cross member out of the way, the torsion bars can be pulled from the lower control arms and removed. Save these nuts and bolts for re-use on reassembly.
4. Disconnect the ABS sensor wire and secure it out of the way to prevent damage to the wiring or connector ends.
5. Remove the brake caliper assembly from the rotor and secure it away from the work area.
Note: Be careful with the brake lines! Do not kink or strain these components.
6. Remove the 6 bolts that attach the CV axle to the differential. Save these for re-use.
7. Detach the outer end of the tie rod from the spindle assembly. Special tools are available to safely remove these without damage to the joint or the protective boot. Your GM service manual has details on this procedure.
8. Remove the sway bar links that connect the sway bar to the lower A-arm. Save this hardware for re-use on reassembly.
9. Remove the shock absorber mounting bolts from the lower A-arm. Save this hardware for re-use.
10. Remove the upper and lower A-arm pivot nuts. Save this hardware for use on reassembly.
11. Support the A-arm assembly and carefully remove the pivot bolts. Lower the assembly to the floor and set aside. This assembly is relatively heavy and not rigid. Be *very* careful when removing it. Save the pivot bolts for re-use.
12. Remove the upper shock nuts and remove the stock shock absorbers. Discard these parts.

Repeat steps 4 through 12 on the remaining side of the vehicle:

13. Detach the front drive shaft from the differential yoke and remove it from the vehicle. Discard this drive shaft.
14. Disconnect the electronic sensor wiring and vent line from the differential and secure them out of the way.
15. Remove the factory bump stops by using a large channel lock type of pliers and discard the stops.

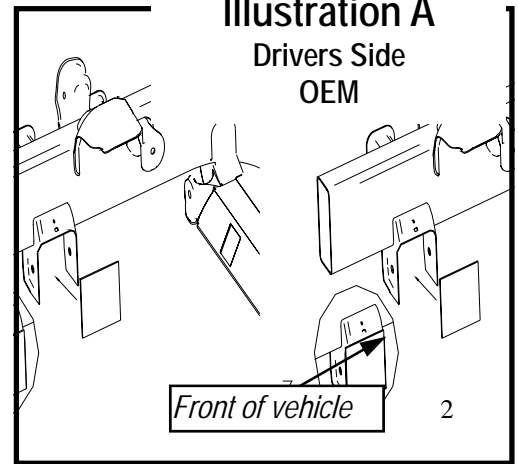
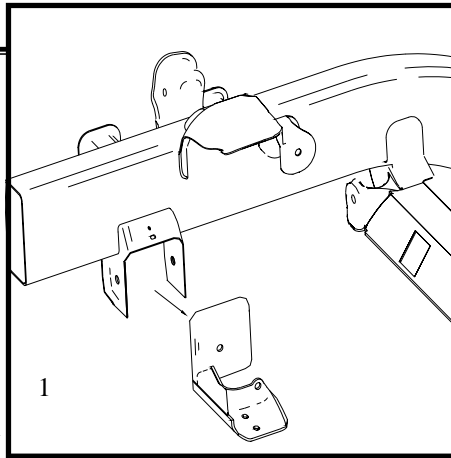

16. Remove the drag link from the pitman arm and idler arm. Set this assembly aside. Save the nuts for re-use.

Note: Sometimes, it may be easier to remove the Idler arm from the frame while still fastened to the drag link.

17. Remove the front differential lower mounting bolt. Save this nut and bolt for re-use.
18. Remove the passenger side differential mounting bolts. Save this hardware for re-use.
19. Remove the differential cross member and discard this hardware.

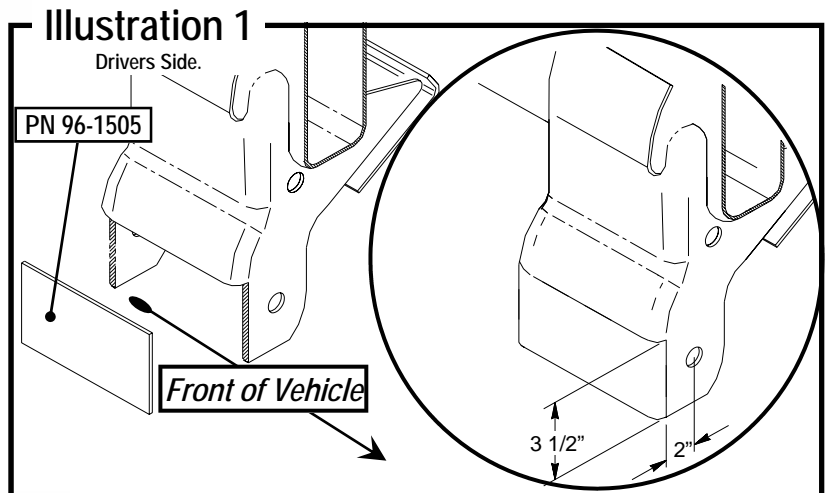

20. While supporting the differential, remove the upper mount bolt and carefully lower the differential to the ground. Retain this nut and bolt for re-use on reassembly.

21. Using a 2" hole saw without the pilot drill, remove the bump stop mount from the frame on each side of the vehicle. It is important that you do not remove any more material than you have to.

IMPORTANT: Do NOT drill through this pad with the hole saw!

22. Using an angle grinder or equivalent, remove any remaining weld from this area to achieve a smooth surface.
23. Using a reciprocating saw or other suitable saw, on the driver side A-arm pocket / differential mount, cut the rear section out as shown in **Illustration A** and to the dimensions shown in **Illustration 1**.

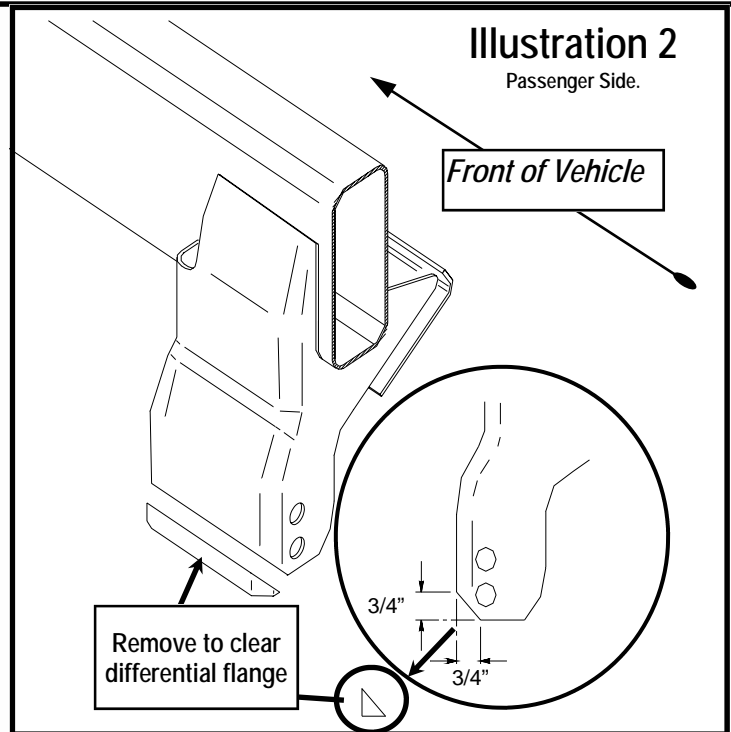

24. On the passenger side mount, cut a 45° section from the pocket as per **Illustration 2**.

25. On the OE bump stop flanges on both sides of the truck, cut the front corners where indicated in **Illustration 3** to assure adequate shock clearance.

26. On the front upper A-arm mount pockets, knock the existing alignment cam pins off with a hammer and grind the surface smooth. Make sure you are wearing your safety glasses!

27. Install the provided replacement bump stops (PN 15-11018) to the main cross member as indicated in **Illustration 4**.

Note: It is important that this is done now as it is not possible to install these stops after the installation of the cross member.

28. With the differential out of the vehicle, temporarily mount the main (rear) cross member (PN 90-1459) to the frame using the existing lower A-arm pockets and OE bolts. Make sure that the cross member is located with the inside face of the rear flange even with the rear edge of the OE bump stop

flange as noted in **Illustration 3** (the driver side should look the same as the passenger side when properly located). When the location is set, clamp the cross member to the flanges to prevent movement and drill the 2 upper mount holes through the OE flange on both sides of the truck. The bottom hole is not accessible with a drill at this time, it must be marked for later drilling. Install the 3/8" X 1 1/4" NC bolts, washers and Stover nuts provided and tighten them to prevent movement. On the driver side, tighten up the bottom OE through bolts until there is about .030" clearance between the cross member and factory pocket sides. Place the supplied 1/8" X 3 1/2" X 4" plate (PN 96-1505) across the cutout at the rear of the pocket, trim if needed, and tack weld this piece in place. These welds must be sufficiently strong to withstand the removal of the cross member for the next steps. See **Illustration 1**.

29. Now remove the rear cross member. Finish welding the replacement plate to the back of the pocket. Drill the remaining 3/8" holes marked in the previous step through the OE flanges on both sides of the vehicle.

Note: It is very important that these bolts are installed. Do not skip this step.

30. Install the differential lowering shackle (PN 90-1446) into the OE location with the original nut and bolt. See **Illustration 5**.

31. Install the passenger side spacer bracket (PN 90-1447) to the OE mount using the original hardware at the top.

Note: The bracket is slightly tapered. The narrow

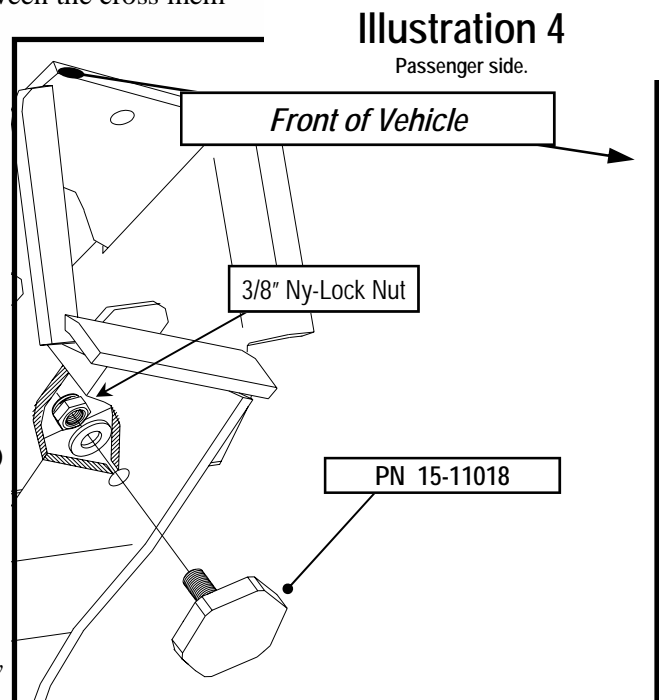
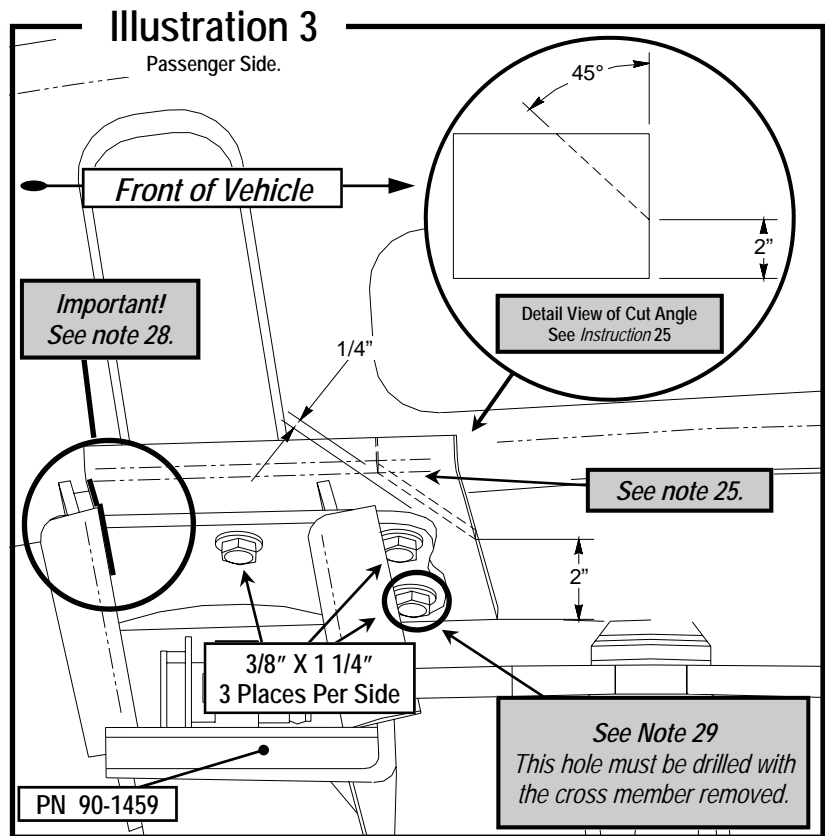

end of the taper is oriented to the rear of the truck!

Tighten OE fasteners to specifications. See **Illustration 6**.

32. Hang the differential from the shackle using the supplied **9/16" X 3 3/4"** bolt, washers, and nut. Insert the bolt from the center of the truck to the outside and install the supplied torque strut (**PN 90-2202**) as shown in **Illustration 5**. Install the supplied washer and lock nut and tighten the assembly enough so that the strut can be moved without much effort to complete step 33.

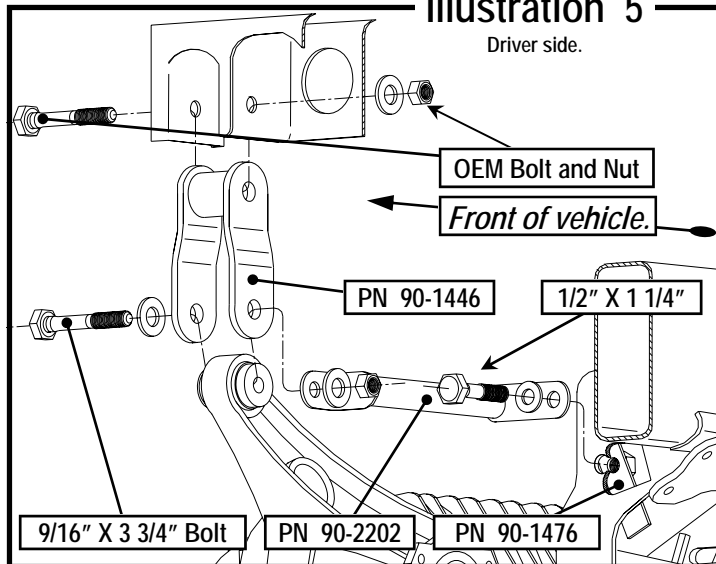

33. Attach the differential to the passenger side spacer bracket as shown in **Illustration 6**. Use the supplied **9/16" X 1 1/2"** bolts, 2 SAE washers, 2 USS (large Diameter) washers, and nuts. The USS washers go onto the slotted aluminum flange of the differential. At this point leave the fasteners slightly loose until the main cross member is back in place and the torque strut is positioned.

32. Rotate the differential torque strut up and to the rear until the mount hole is at its closest point to the truck frame as shown in **Illustration 5**. Mark the location of the hole. After marking this location, rotate the strut out of the way and drill this hole to clear a **1/2"** bolt. Rotate the strut back into place and install the supplied **1/2" X 1 1/4"** bolt through the strut and through the frame member. A **1/2"** nut plate (**PN 90-1476**) is supplied to facilitate this installation, position this nut plate over the bolt on the inside of the A-arm pocket and start the bolt by hand. Leave all hardware loose until the completion of the cross member installation.

33. Reinstall the rear cross member into the truck while carefully guiding the differential mount bushing into it's mounting flange on the cross member. Use the OE bolts to hold it in place. Install these bolts with the threads pointing away from the CV joints. Install the OE bolt through the new cross member and differential bushing with the threads to the outside of the truck and install the OE nut. Finish installing the **3/8" X 1 1/4"** nuts, bolts, and washers to the upper flange mounts on both sides of the vehicle and torque all cross member hardware to specifications on page 17.

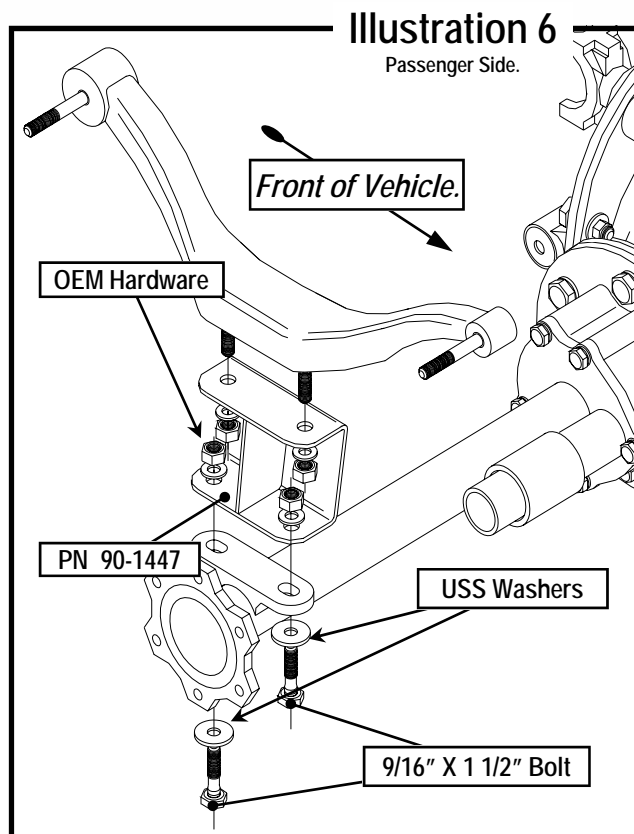

34. Using the differential drop extension pack (**PN 90-6189**) fit the new hose to the differential. Place the supplied plug in the end of the tube and connect the factory tube to it. Reinstall electronic wiring to the differential. You will have to reroute these for proper fit.

35. Tighten all differential mounting hardware to specifications at this time.

36. Install the Pro Comp. center link drop (**PN 90-2196**) to the pitman arm and idler arm using the factory nuts. See **Illustration 7**.

Note: When properly installed, the drop is perpendicular to the ground.

Illustration 7

Passenger Side.

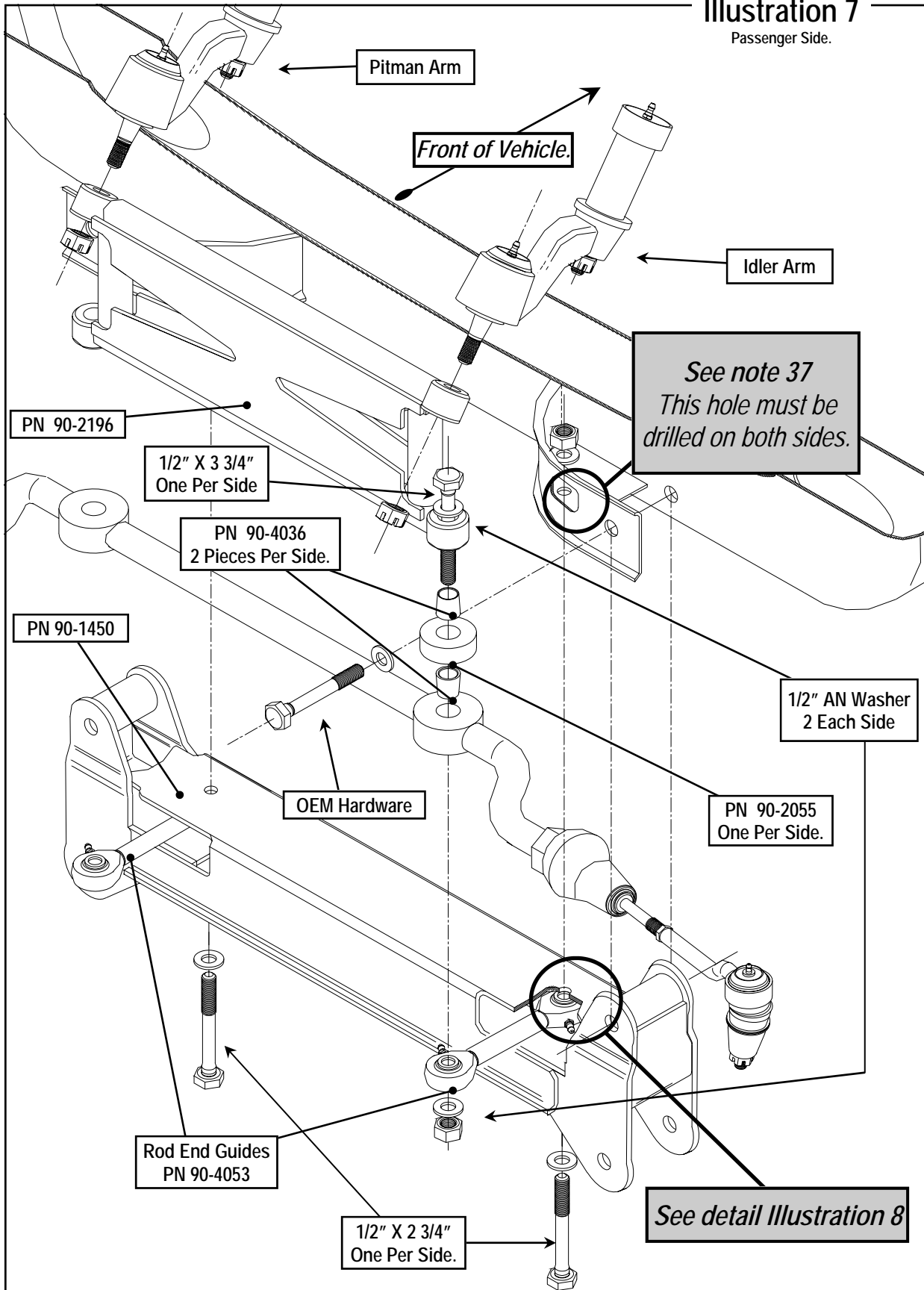

37. Mount the front cross member (PN 90-1450) to the existing front lower A-arm pockets with the OE bolts and nuts. Tighten to specs. Using the cross member as a guide, drill through the factory frame material and install the 1/2" X 2 3/4" bolts provided at this time. See hi-lighted note in **Illustration 7** for the location.
38. Loosely install the OE center link to the center link drop using the supplied 1/2" X 3 3/4" Bolts and other hardware supplied (PN's 90-2055, 96-4036, 90-4053, & 1/2" AN washers) as indicated in **Illustration 7**. Leave the lock nuts loose for the moment.

Note: For correct operation, follow this illustration exactly!

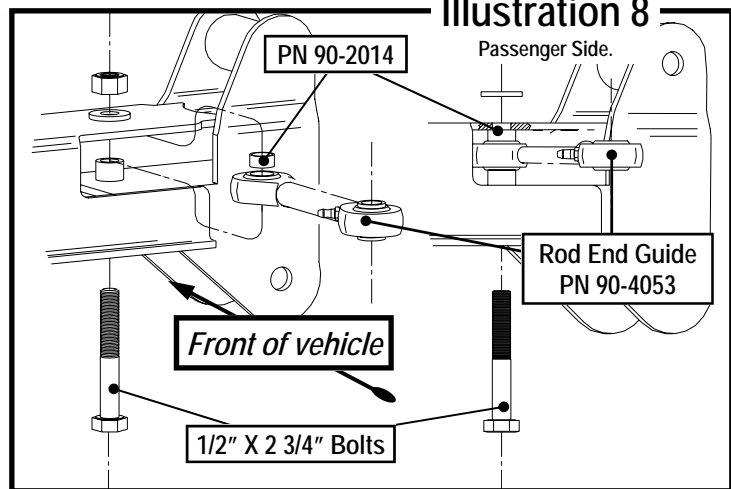

39. Now install the rod end guides (PN 90-4053) to the front cross member as shown in **Illustrations 7 & 8**. Use the supplied 1/2" X 2 3/4" bolts, spacers (PN 90-2014), washers, and nuts. Place the ends of the rod ends onto the drop link bolts. Snug up the bolt assemblies and rotate the steering assembly back and forth several times to check for clearance. Additional washers are supplied to facilitate the correction of any misalignment issues you may encounter. It is very important to ensure no binding occurs throughout the entire range of motion of the steering assembly. Once correct clearances are established. Torque all fasteners to specifications.
40. At the front of the OE A-arm stop, it will be necessary to grind the existing droop stop tab back enough to clear the new PN 90-1466 hardware as shown in **Illustration 9**.

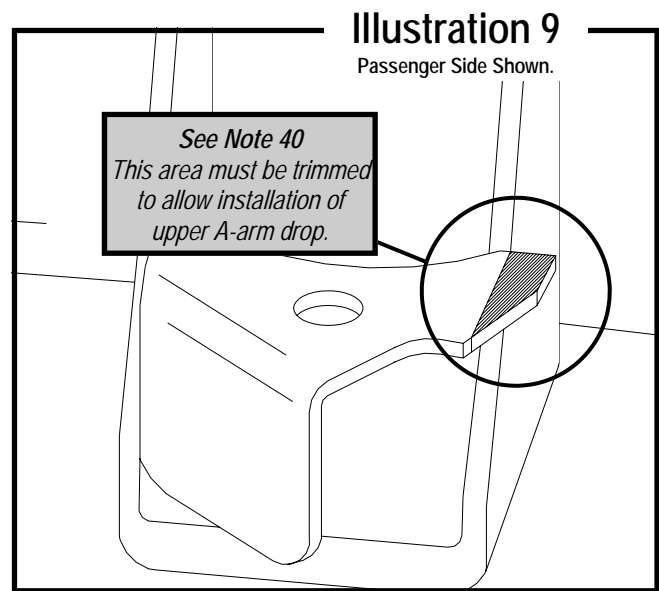

41. Install the front, upper A-arm drops (PN 90-1466) to the existing upper pockets using the supplied 9/16" X 1 1/2" bolts, and the 7/16" X 1 1/4" bolts, washers, and nuts from the bottom of the adapter through the existing holes in the OE frame. The back hole in the adapter must be drilled as indicated on **Illustration 10**. Leave these fasteners slightly loose until the sway bar is installed.
42. The factory sway bar is remounted upside down using the OE bushings and clamps. They mount to the original location with spacer (PN 90-1496), supplied 3/8" X 2 1/4" socket head cap screws, washers, and lock nuts. Drill out the sway bar mounting threads to clear the 3/8" bolts (13/32"). See **Illustration 10**. For the moment, tighten the bushing bolts enough to facilitate the installation of the end links. Tighten all A-arm hardware to specs. Do not tighten the sway bar hardware until the end links are in place.
43. Assemble the compression strut bushings and sleeves into the struts as shown in **Illustrations 11 & 12** using the components in part pack PN 90-6179.
44. Position the compression struts (PN 90-2126) into the tabs on the front cross member using the supplied 1/2" X 4" bolts, washers, and nuts. See **Illustration 11**. The strut end with the tube ends welded at an angle go to the front, the struts are angled from the front mounts to the outside of the vehicle. Loosely place the compression strut mounts (PN 90-1435) onto the transmission cross member using the supplied 1/2" X 1 1/4" bolts, washers, and tab nuts. See **Illustration 12**. The location of the rear mount is dependant on the transmission option in your vehicle. Swing one compression strut up to its previously installed mount and

position the mount to ensure easy insertion of the mounting cross bolts. You may have to rotate the saddle or use the other hole (or slot) to achieve a satisfactory fit. Swing the strut back out of the way and torque the rear strut mount bolt to specifications being careful to maintain its position. Repeat this procedure for the other side. Reinstall the struts with the remaining **1/2" X 4"** bolts, washers, and nut plate (**PN 90-1476**) and torque all to specifications.

45. Check all mounting hardware and adapters for correct fit and check all fasteners to make sure they are in place and correctly tightened.
46. Install the lower A-arm assemblies on each side of the vehicle by reversing the disassembly order. Attach the lower A-arms using the supplied **5/8" X 5 1/2"** bolts at the rear and the **5/8" X 4 1/2"** bolts at the front with washers and nuts. The upper A-arms are installed using the new alignment cam bolt (**PN 42-778T**) assemblies. They are installed with the threads *away* from the center of the A-arm as shown in **Illustration 13**. Be careful not to damage the ABS sensor wire. **DO NOT** tighten the pivot bolts at this time. For correct positioning of the urethane bushings, the vehicle should be fully on the ground before these bolts are torqued to specifications.

Note: If there is excessive space between the upper a arm and the new cross member shim the space out with the contents of an 90-6275.

Illustration 10

Passenger Side.

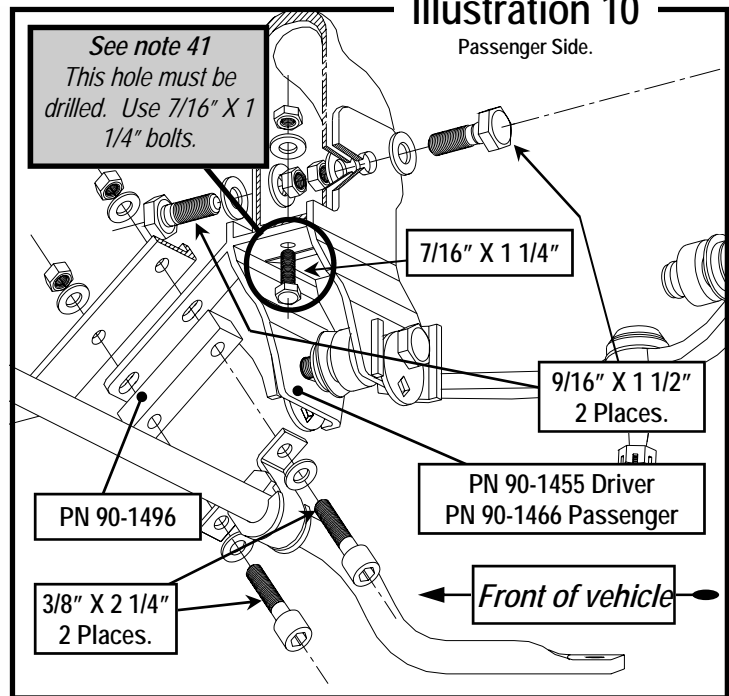

Illustration 11

Front Cross Member

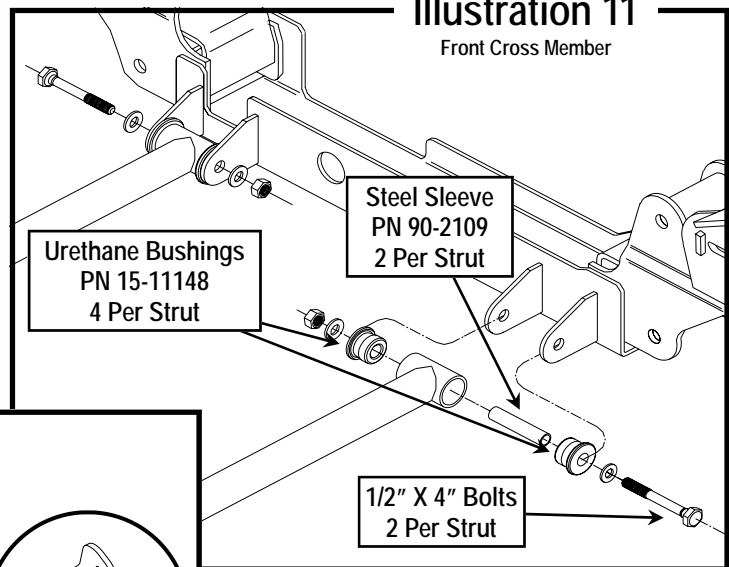
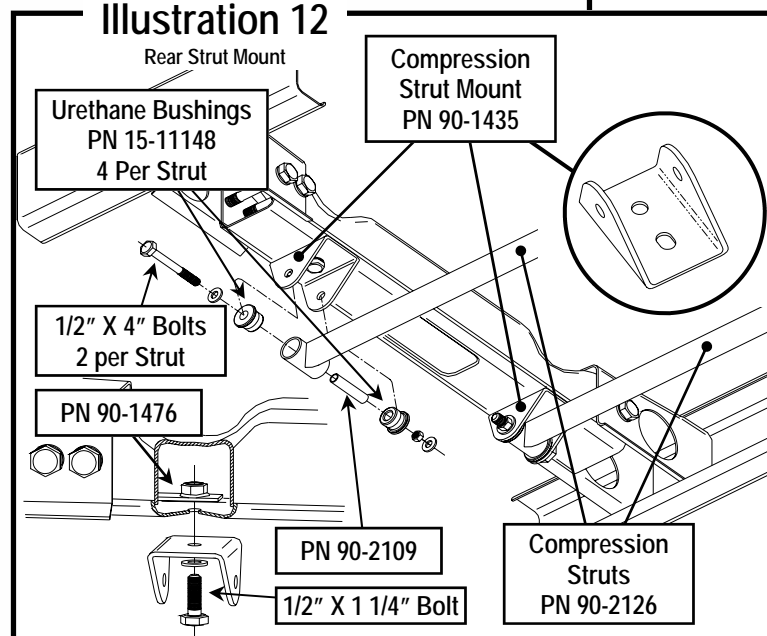

Illustration 12

Rear Strut Mount



47. Install the factory half shafts to the differential with the OE bolts. Torque to specifications.

48. Install the sway bar link to the sway bar and lower A-arm with the OE links and hardware. Tighten these until the bushings just start to bulge out. Do not over tighten!

49. Install the front Pro Comp shock absorber (**PN 920590**) to the original position using adapter (**PN 90-1079**) for the upper mount and the OE bolts and nuts for

the bottom mount. See **Illustration 16**.

47. Install the new front drive shaft (**PN 90-4051**) into the vehicle and bolt it to the front differential using the OE hardware.
48. Install the tie rod ends to the steering knuckle and torque to factory specifications.
49. Install the front caliper assemblies to each side

VERY IMPORTANT! -REMEMBER TO of the
PUMP THE BRAKES UP BEFORE
DRIVING YOUR VEHICLE!

truck.

50. Remove the factory brake line brackets from the frame. Using the supplied brackets (**PN 90-1868**) and the previously removed factory bolt attach the new bracket in place of the stock bracket with the bends facing down. Attach the stock brake line bracket to the new bracket using the new hardware (**PN 90-6299**).
51. Install the ABS sensor wiring and secure them to the brake lines with “zip-ties”. Again, the harness must be routed to prevent breakage or chaffing. Move the A-arm assembly up and down to its limits several times with the spindle full left and full right, to check for binding and to ensure that there are no interference or pinching problems with the brake lines and

Illustration 13

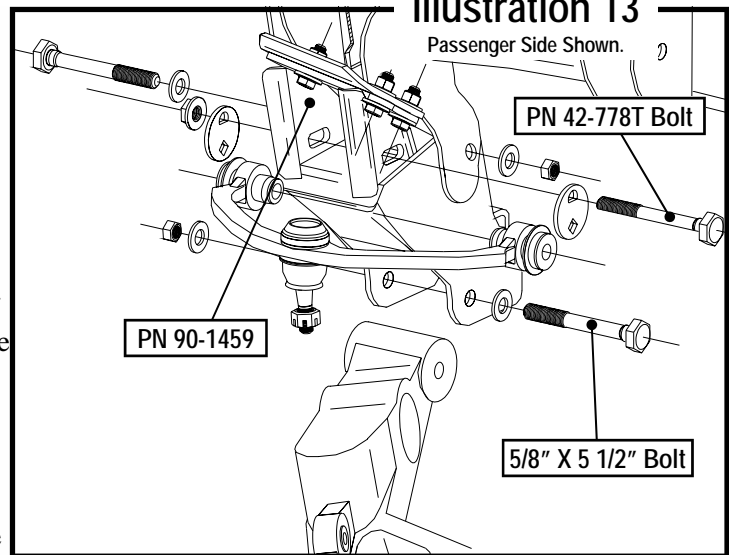

Illustration 14

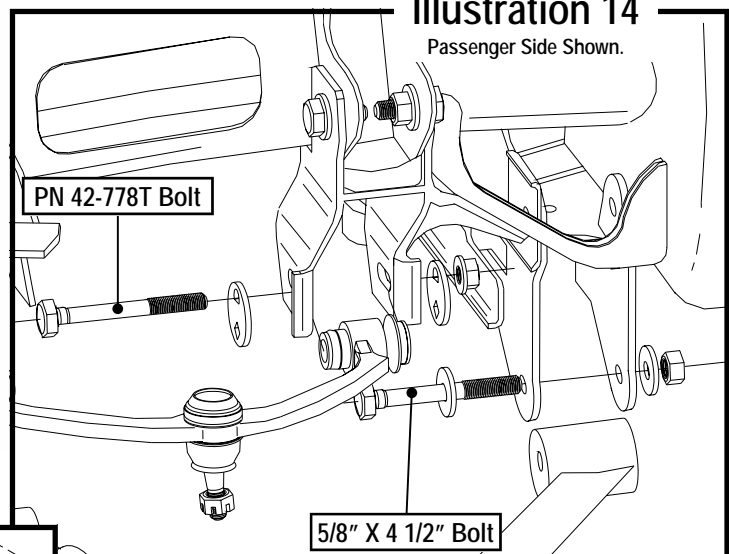

Illustration 15

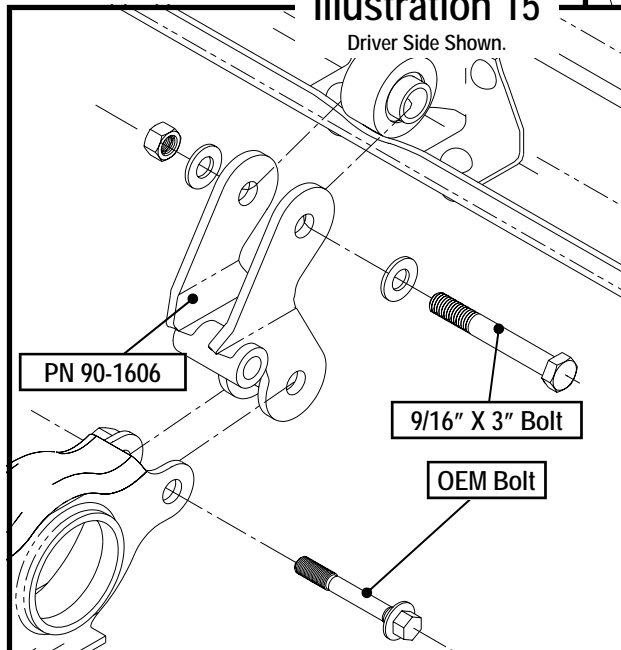
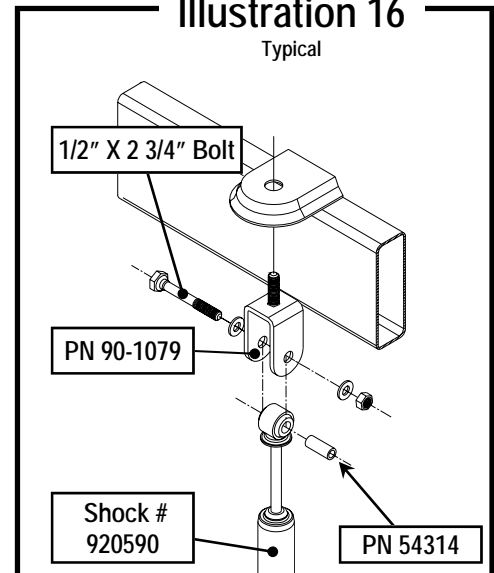

Illustration 16



ABS wiring.

52. Install the torsion bar cross member drops by locating the new parts (PN 90-1606) in place as shown in **Illustration 15**. Use the supplied 9/16" X 3" bolts at the top and the OE fastener at the bottom.
53. Install the OE cross member to the drops using the OE bolts.
Note: The weld nuts on the cross member are oriented to the rear.
54. Install the Torsion bars by reversing the order in which they were removed. Again, be very careful to install them with the same orientation that they were removed (i.e., left front to left front, right front to right front). Reset the preload bolts to the same measurements previously taken in **Instruction #2**.
55. With the truck still on jack stands and the suspension hanging at full extension, cycle the steering from lock to lock to check that all components have clearance and operate freely. Pay very close attention to the ABS wiring and brake lines.
56. Reinstall your wheels and tires and properly torque the lug nuts to factory specs. Again check all areas around the suspension and tires for clearance issues.
57. Lower the truck to the ground to preload the suspension and unload the upper A- arms. Tighten the lower A- arm pivot bolts to specifications. It is necessary to rotate the upper A-arm alignment cam bolts to a neutral position (in the center of the alignment slot) and then tighten the cam bolts to specifications. This step is necessary to allow you to get to a professional alignment shop only! Do not assume that this setting is "close enough" and skip the alignment!

Bolt Torque and ID						
Decimal System			Metric System			
All Torques in Ft. Lbs.						
Bolt Size	Grade 5	Grade 8	Bolt Size	Class 9.8	Class 10.9	Class 12.9
5/16	15	20	M6	5	9	12
3/8	30	45	M8	18	23	27
7/16	45	60	M10	32	45	50
1/2	65	90	M12	55	75	90
9/16	95	130	M14	85	120	145
5/8	135	175	M16	130	165	210
3/4	185	260	M18	170	240	290

<p>1/2-13x1.75 HHCS</p> <p>D T L X</p>	<p>Grade 5</p> <p>G</p>	<p>Grade 8</p> <p>G</p>	<p>M12-1.25x50 HHCS</p> <p>D T L X</p>
<p>G = Grade (Bolt Strength)</p> <p>D = Nominal Diameter (Inches)</p> <p>T = Thread Count (Threads per Inch)</p> <p>L = Length (Inches)</p> <p>X = Description (Hex Head Cap Screw)</p>		<p>P = Property Class (Bolt Strength)</p> <p>D = Nominal Diameter (Millimeters)</p> <p>T = Thread Pitch (Thread Width, mm)</p> <p>L = Length (Millimeters)</p> <p>X = Description (Hex Head Cap Screw)</p>	

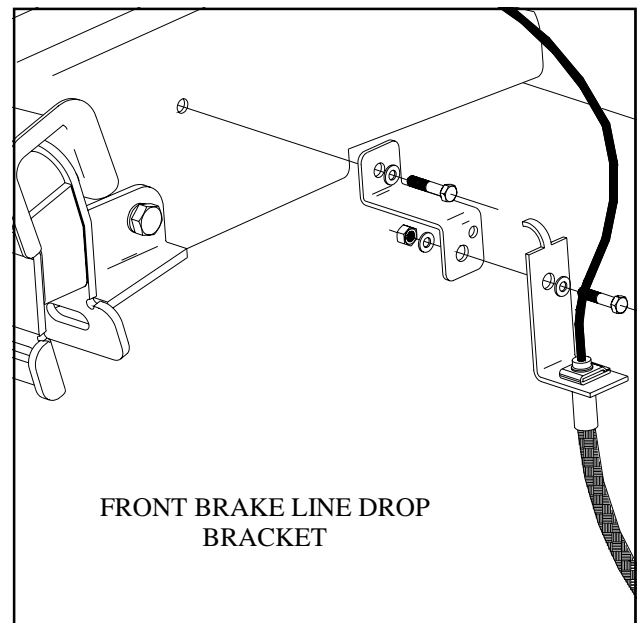

Rear Kit Installation

1. Raise the rear of the vehicle enough for the tires to clear the ground and use jack stands on the frame to support the truck. Remove the rear tires and wheels.
2. Support the differential with your floor jack and remove the OEM shock absorbers. It may be necessary to raise the differential housing slightly to facilitate their removal.
3. Completely remove the sway bar links from both ends of the sway bar. Save the fasteners.
4. Remove the OE bolts from the differential track bar at the upper track bar mount. Save this hardware.
5. Remove the brake line mount bolt at the upper front location of the vehicle gas tank. See **Illustration A**.
6. Carefully lower the differential away from the vehicle and remove the stock springs.

Important: Be very careful not to damage the brake lines! Remove mounting brackets as needed to allow the brake lines freedom of movement sufficient to avoid damage. Remember to reinstall them when done.
7. At the OE bump stop, measure from the center of the existing hole at the rear 2.800 inches toward the front of the vehicle and carefully mark and center punch this loca-

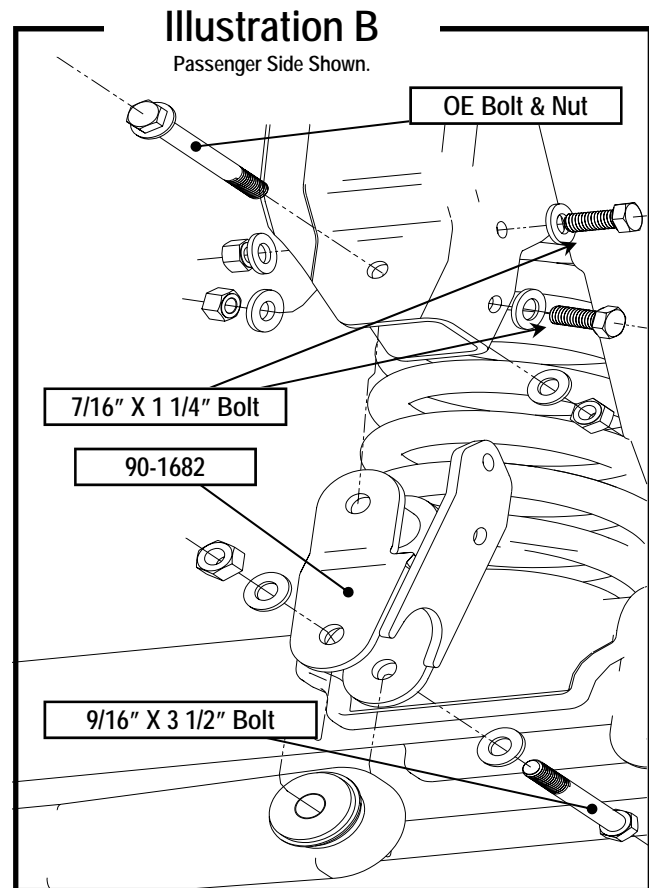
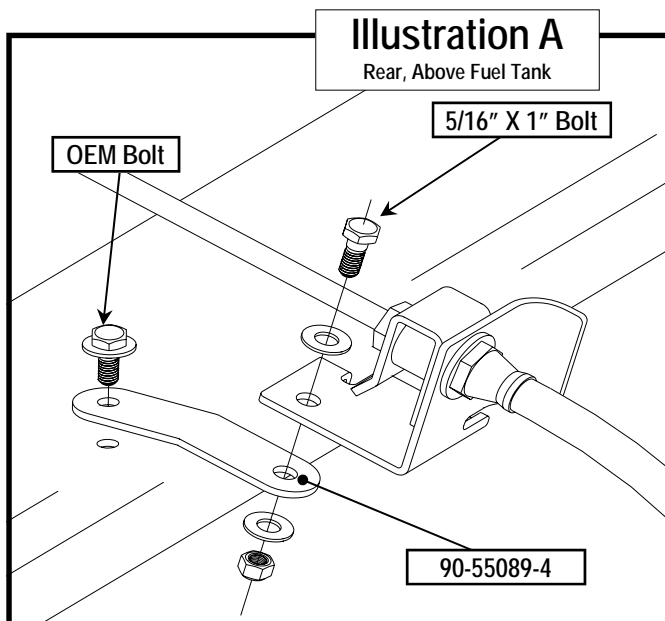

tion. Keep the center line between the two holes, parallel to the vehicle center line. Drill through this location with a 1/2" drill bit. See **Illustration C**.

8. Using **Illustration C** as a guide, install the bump stop extension plates (PN 90-3146) to the existing bump stop by first installing one 3/8" X 1" bolt and lock washer through one of the holes in the bump stop extension. Slide the nut plate (PN 90-1702) between the OE bump stop and the lower trailing arm until the back nut lines up with the hole in the OE bump stop. Take the bump stop extension with its bolt and place it on top of the pad and start the bolt into the nut plate. Rotate the nut plate to the location of the previously drilled front hole and start the second 3/8" X 1" bolt with lock washer into the remaining nut on the nut plate. Tighten these bolts to 45 ft-lbs

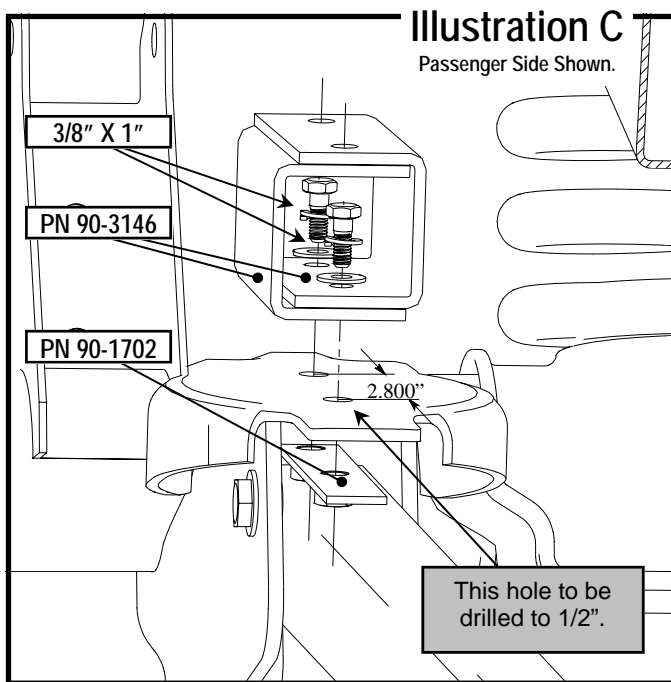

9. Repeat this procedure on the remaining side of the vehicle. ⚙
10. On the rear of the drivers side frame rail, loosen and disconnect the parking brake adjuster cable connector and nut. Compress the retaining fingers on the rear cables and pull the parking break cables away from the frame.
NOTE: Mark the upper and lower cables so they can be put back in the same orientation.
11. Remove the nuts and bolts attaching the upper and lower rear control arms on the driver's side of the frame. Do not remove the control arms from the passenger side .
12. Loosen the bolt attaching the lower control arm to the axle bracket. Allow the lower control arm to hang downward.
13. Attach the control arm drop bracket (DRIVER'S PN 90-1785 and PASSENGER PN 90-1790) to the frame using the original bolts. **SEE ILLUSTRATION G.**
14. Drill a 1/2" hole through the bottom of the lower frame bracket hole and the frame. Install the 1/2" hardware from hardware pack 90-6276.

15. Tighten the 1/2" nut and bolt to 65 ft-lbs and the original bolts to 80 ft-lbs.
16. Pull the parking brake cables through the new control arm drop bracket, the top cable through the bracket and the bottom cable through the hole in the side of the bracket. Connect the parking brake cable connector and nut. Adjust parking brake tension to factory specifications.
17. Loosely attach the upper control arm to the control arm drop bracket with the 9/16" X 3.5" bolt, washer and nut from hardware pack 90-6276.

NOTE: Do not tighten the pivot bolts until the vehicle is at its new ride height.

18. Loosely attach the lower control arm to the control arm drop bracket with the 9/16" X 4" bolt, washer and nut from hardware pack 90-6276.

NOTE: Do not tighten the pivot bolts until the vehicle is at its new ride height. **SEE ILLUSTRATION F.**

19. Repeat the control arm drop bracket installation on the remaining side of the vehicle. ⚙
20. Compress the new spring with a coil spring compressor.
21. Continue to lower the differential until enough space exists to install the new Pro Comp springs, **PN 51021-4.**

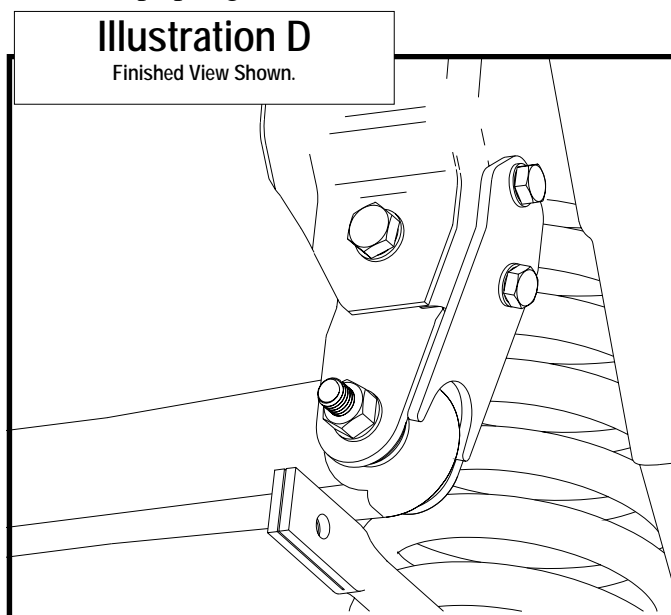
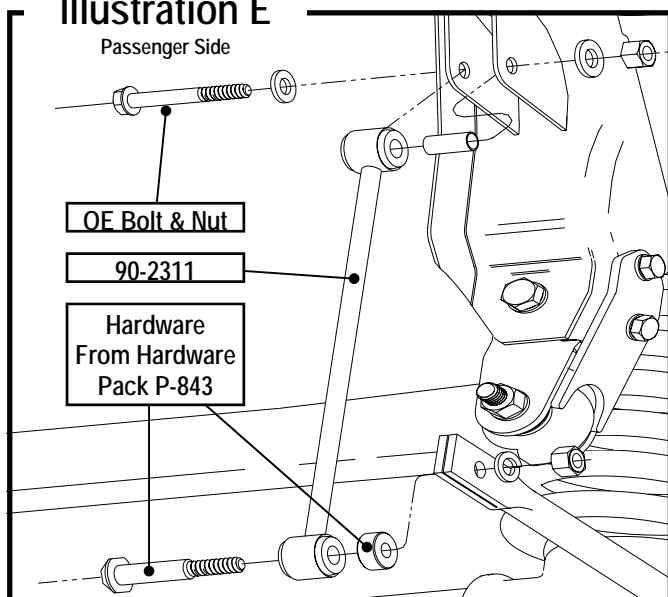

Illustration E

Passenger Side



NOTE: If the factory spring has a rubber pad remove it and install it on to the new spring.

22. You may have to release some slack in the differential vent hose by lightly pulling the excess down from the frame.
23. Repeat this procedure on the remaining side of the vehicle. ⚙
24. Raise the rear end until the new Pro Comp shock absorbers, **MX6098**, can be installed. Ensure that the new springs are seated properly.
25. Using the OE bolt, install the brake line relocation bracket (**PN 90-55089-4**) to the OE brake line mount position as shown in **Illustration A**. Bolt the OE bracket to the new relocation bracket using the **5/16" X 1"** bolt, nut, and washer provided.
26. Using **Illustration B** as a reference, install the track bar relocation adapter **PN 90-1682**. Place the adapter into the OE mount and use the OE bolt to hold it in place. On the passenger side of the adapter are two holes that are used as drill guides for a **7/16"** drill. Drill completely through the OE mount and install the **7/16" X 1 1/4"** bolts, nuts, and washers provided. Torque these bolts

to the bolt specifications in the rear of this manual.

27. Install the track bar into the newly installed adapter using the provided **9/16" X 3 1/2"** bolt, nut and washer. Torque these bolts to the bolt specifications in the rear of this manual.
28. Install the sway bar using the new end links PN **90-2311**. Use the bushings and sleeves from **90-6235**. Use the OE bolt and nut on the top and use the hardware from pack **P-843** on the bottom. Torque these bolts to the bolt specifications in the rear of this manual. **SEE ILLUSTRATION E**.
29. Torque all fasteners.
30. Install your wheels and tires, then lower the vehicle to the ground.
31. With the vehicle on the ground and Tighten control arm bolts to OE specifications.
32. After installation is complete, double check that all nuts and bolts in the front and rear are tight. Refer to the chart at the end of this document for torque specifications. Unless otherwise directed, use this chart for all torque specs.

33. Recheck for proper installation,

Illustration F

Driver's side

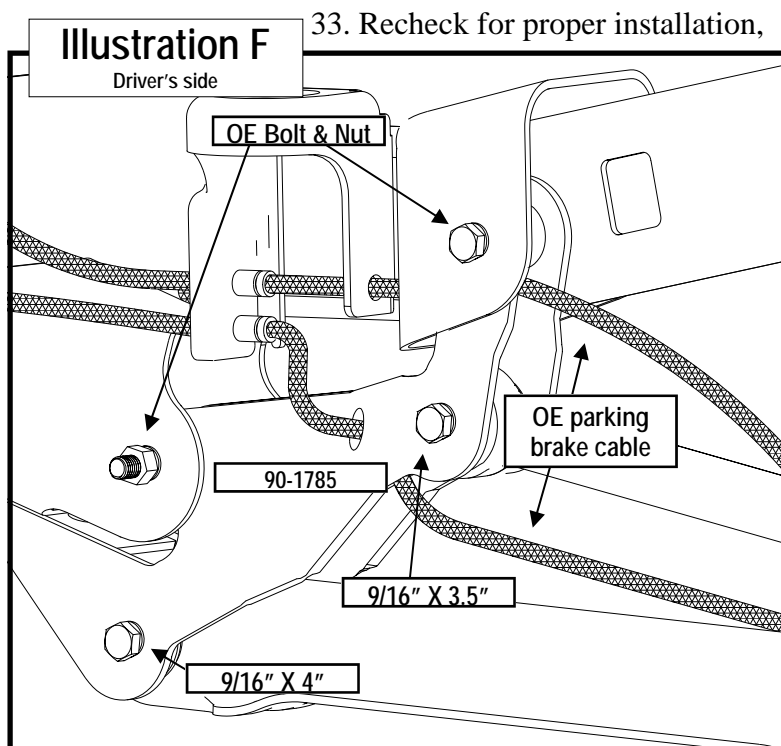

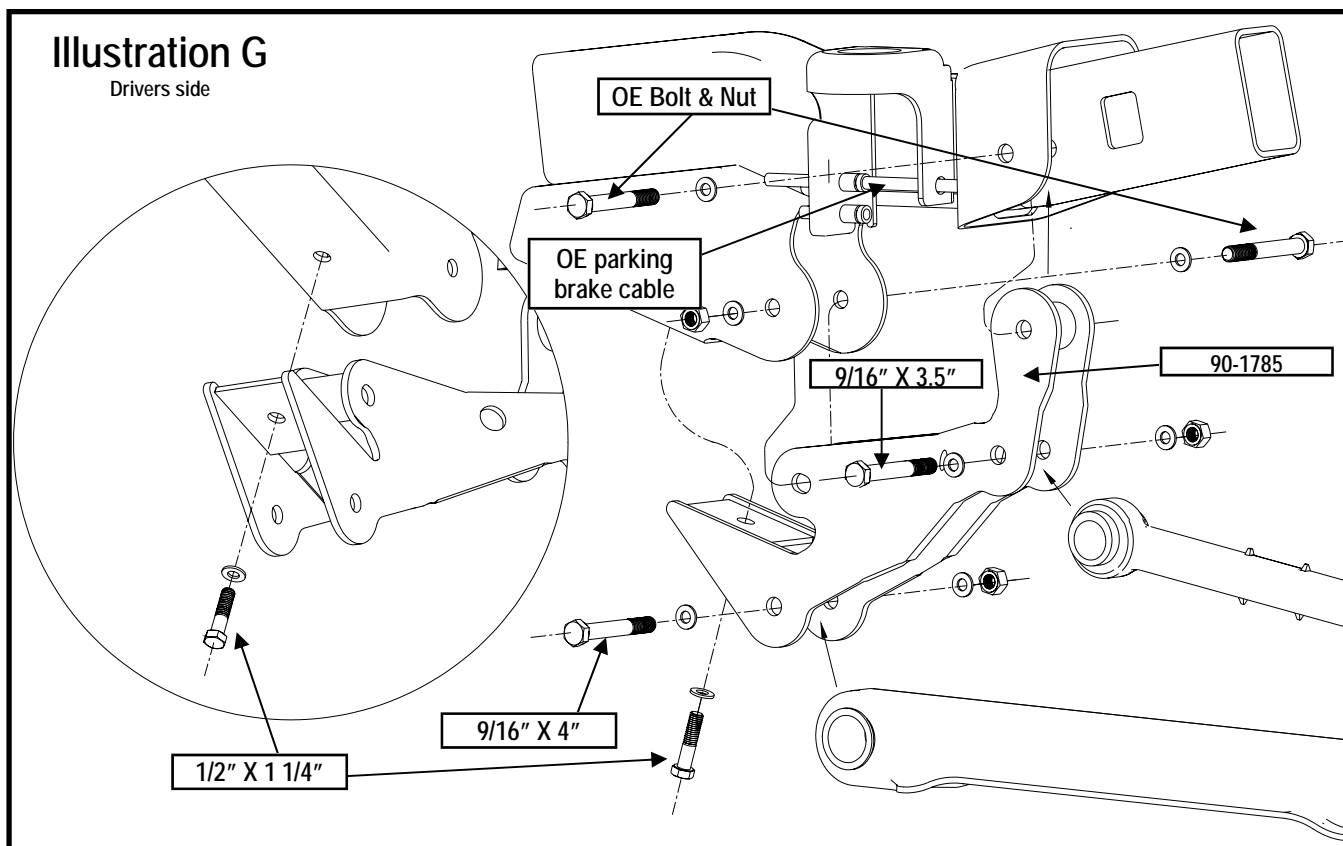

then torque all newly installed hardware.

34. After 100 miles, recheck for proper torque on all newly installed hardware.
35. Recheck all hardware for tightness after each off road use. ⚠

Final notes:

1. If new tires are installed that are more than 10% taller than original tires, the speedometer must be recalibrated for the rear wheel anti-lock brake system to function properly. Contact an authorized GM dealer for details on recalibration.
2. With vehicle on the floor, cycle the steering from lock to lock and inspect the steering, suspension and driveline systems for proper operation, tightness and adequate clearance. Recheck brake hose/fittings for leaks. Be sure all brake lines are long enough for safe operation.
3. Have headlights readjusted to the proper settings.
4. Realign front end to factory specifications. Be sure the vehicle is at the desired ride height prior to realignment.
5. Recheck ALL fasteners at 100 miles to make sure they have not come loose. Due to the additional wear and tear created by larger tires and wheels, we recommend that you periodically check the suspension system and steering components to ensure service life and safe vehicle operation.

Notice to Owner operator, Dealer and Installer:

Vehicles that have been enhanced for off-road performance often have unique handling characteristics due to the higher center of gravity and larger tires. This vehicle may handle, react and stop differently than many passenger cars or unmodified vehicles, both on and off-road. You must drive your vehicle safely! Extreme care should always be taken to prevent vehicle rollover or loss of control, which can result in serious injury or even death. Always avoid sudden sharp turns or abrupt maneuvers and allow more time and distance for braking! Pro Comp reminds you to fasten your seat belts at all times and reduce speed! We will gladly answer any questions concerning the design, function, maintenance and correct use of our products.

Please make sure your Dealer/Installer explains and delivers all warning notices, warranty forms and instruction sheets included with Pro Comp product.

Application listings in this catalog have been carefully fit checked for each model and year denoted. However, Pro Comp reserves the right to update as necessary, without notice, and will not be held responsible for misprints, changes or variations made by vehicle manufacturers. Please call when in question regarding new model year, vehicles not listed by specific body or chassis styles or vehicles not originally distributed in the USA.

Please note that certain mechanical aspects of any suspension lift product may accelerate ordinary wear of original equipment components. Further, installation of certain Pro Comp products may void the vehicle's factory warranty as it pertains to certain covered parts; it is the consumer's responsibility to check with their local dealer for warranty coverage before installation of the lift.

Warranty and Return policy:

Pro Comp warrants its full line of products to be free from defects in workmanship and materials. Pro Comp's obligation under this warranty is limited to repair or replacement, at Pro Comp's option, of the defective product. Any and all costs of removal, installation, freight or incidental or consequential damages are expressly excluded from this warranty. Pro Comp is not responsible for damages and / or warranty of other vehicle parts related or non-related to the installation of Pro Comp product. A consumer who makes the decision to modify his vehicle with aftermarket components of any kind will assume all risk and responsibility for potential damages incurred as a result of their chosen modifications. Warranty coverage does not include consumer opinions regarding ride comfort, fitment and design. Warranty claims can be made directly with Pro Comp or at any factory authorized Pro Comp dealer.

IMPORTANT! To validate the warranty on this purchase please be sure to mail in the warranty card.

Claims not covered under warranty-

- Parts subject to normal wear, this includes bushings, bump stops, ball joints, tie rod ends and heim joints
 - Discontinued products at Pro Comp's discretion
- Bent or dented product
- Finish after 90 days
- Leaf or coil springs used without proper bump stops
- Light bulbs
- Products with evident damage caused by abrasion or contact with other items
- Damage caused as a result of not following recommendations or requirements called out in the installation manuals
- Products used in applications other than listed in Pro Comp's catalog
- Components or accessories used in conjunction with other manufacturer's systems
- Tire & Wheel Warranty as per Pro Competition Tire Company policy
- Warranty claims without "Proof of Purchase"
- Pro Comp Pro Runner coil over shocks are considered a serviceable shock with a one-year warranty against leakage only. Rebuild service and replacement parts will be available and sold separately by Pro Comp. Contact Pro Comp for specific service charges.
- Pro Comp accepts no responsibility for any altered product, improper installation, lack of or improper maintenance, or improper use of our products.

E-Mail: tech@explorerprocomp.com
Website: www.explorerprocomp.com
Fax: (619) 216-1474
Ph: (619) 216-1444

PLACE
WARRANTY REGISTRATION
NUMBER
HERE: _____