



INSTALLATION MANUAL
FORD BRONCO FRONT INNER FENDERS
PRODUCT NUMBER: FB2005
APPLICATION: 2021 FORD BRONCO



IMPORTANT SAFETY GUIDE | Your safety and the safety of others is very important.

In order to help you make informed decisions about safety, we have provided the following warnings, safety precautions, installation instructions, and other important information to alert you to potential hazards that could hurt you or others.

Please do a job safety analysis before each task to identify potential hazards for your situation and remove/protect against them. Use own good judgment and take your time.

Check packaged materials immediately upon arrival to ensure that all listed parts are included and undamaged.

Read and understand all warnings, safety precautions, and instructions before installing this product.

SENSORS FIELD OF VIEW MAY BE ALTERED WITH USE OF THE REPLACEMENT BUMPER.

WARNINGS

- Failure to observe the following warnings and instructions provided in this manual could lead to severe injury and/or death.
- For professional installation only. Careless installation and/or operation can result in serious injury, death, and/or equipment damage. All liability for installation and use rests with the user or consumer.
- Fab Fours, Inc. only approves installing this product according to these written instructions with the hardware provided. Failure to install according to these instructions will invalidate the warranty. This includes, but is not limited to, using alternative installation methods, hardware, or materials.
- This product is for off road use only.

SAFETY PRECAUTIONS

- Always remove jewelry and wear eye protection.
- Always use extreme caution when jacking up a vehicle for work. Set emergency brake and use tire blocks. Locate and use the vehicle manufacturers designated lifting points. Use jack stands.
- Always use appropriate and adequate care in lifting components into place.
- Always ensure components will remain secure during installation and operation.
- Always wear safety glasses when installing this kit. A drilling operation will cause flying metal chips. Flying chips can cause serious eye injury.
- Always use extreme caution when drilling a vehicle. Always disconnect power before welding. Thoroughly inspect the area to be drilled (on both sides of material when possible) prior to drilling, and relocate any objects that may be damaged.
- Always use extreme caution when welding a vehicle. Thoroughly inspect the area to be welded (on both sides of material when possible) prior to welding, and relocate any objects that may be a fire hazard. When welding in a cab, make sure the interior surfaces are covered (e.g., welding blanket) and a fire extinguisher is at hand.
- Always use extreme caution when cutting and trimming during fitting.
- Always tighten all nuts and bolts securely per installation instructions.
- Always route electrical cables carefully. Avoid moving parts, components that become hot, and rough or sharp edges.
- Always insulate and protect all exposed wiring and electrical terminals.
- Perform regular inspections and maintenance on mounts and hardware.

TABLE OF CONTENTS

- 2 SAFETY / DISCLAIMER
- 3 TABLE OF CONTENTS
- 4 A MESSAGE FROM THE OWNER
- 5 GETTING STARTED
- 6 PROVIDED MATERIAL
- 8 DISASSEMBLY
- 9 INSTALLATION
- 14 CONTACT

A MESSAGE FROM THE FOUNDER



Fab Fours' was born out of a passion for customizing vehicles and a love of the outdoors. Our engineering team uses the latest 3D design software to turn new product ideas into reality. In our factory, designs come to life with the combination of cutting edge technology for metal cutting and forming and an American workforce that puts its' heart and pride into every product.

From design and manufacturing, to quality and delivery, Fab Fours' mission is to be the market leader for steel truck and jeep accessories. We make sure a quality product is delivered on time, more than expected, better than expected to our customers.

Enjoy your new Fab Fours product. Welcome to the family!

Greg Higgs

FOUNDER, FAB FOURS

GETTING STARTED

Before you begin the installation process of your new Fab Fours product, we suggest laying out all materials and parts on a pad or protective surface.

Failure to fully account for all components before beginning installation may leave vehicle immobile until part is acquired. Refer to the next pages as an inventory check.

PROVIDED MATERIALS

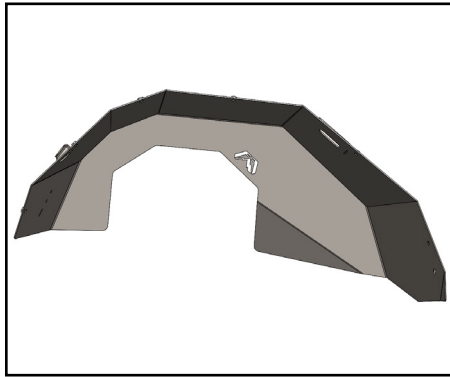

22988 - DS Inner Fender

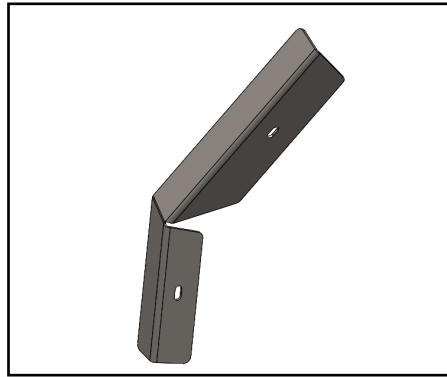

22989 - DS Front Bolt on Panel

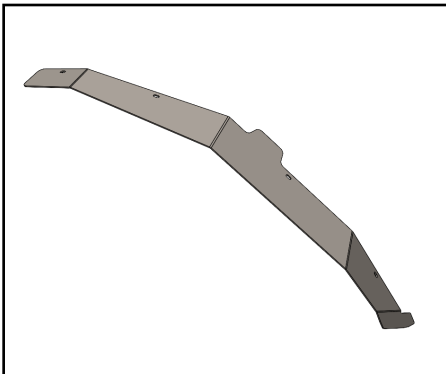

22990 - DS Top Bolt on Panel

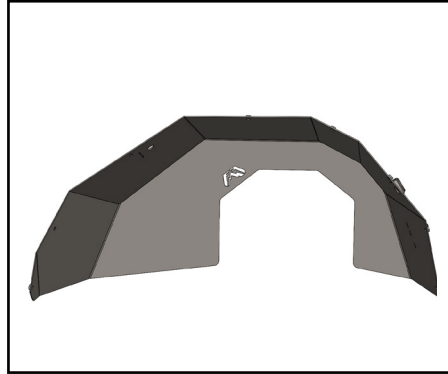

22991 - PS Inner Fender

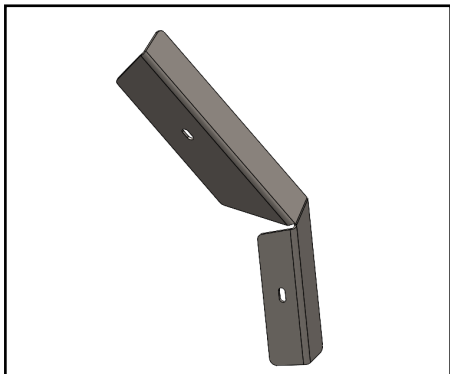

22992 - PS Front Bolt on Panel

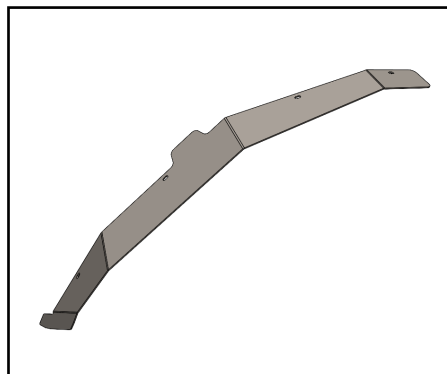

22993 - PS Top Bolt on Panel

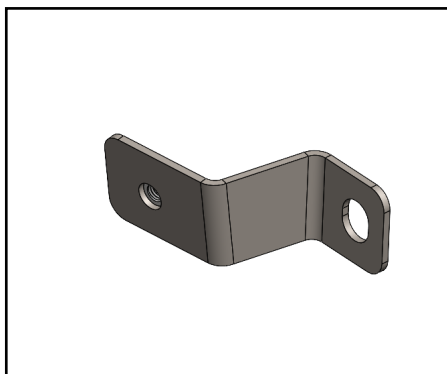

22997 - DS Rear Mount Bracket

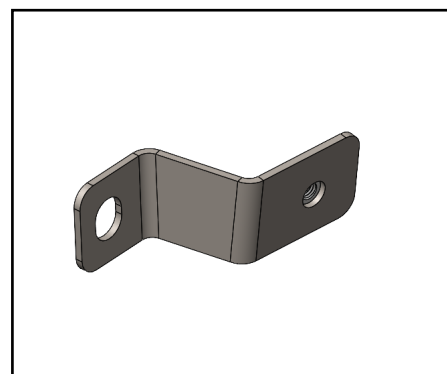

22998 - PS Rear Mount Bracket

TOOLS REQUIRED

- PLASTIC PUSH RIVET REMOVAL TOOL
- NEEDLE NOSE PLIERS
- PHILLIP'S HEAD SCREWDRIVER
- 7MM SOCKET WRENCH
- 10MM SOCKET WRENCH
- 13MM SOCKET WRENCH
- 5/16" SOCKET WRENCH
- 3/8" COMBINATION WRENCH
- 7/32" ALLEN WRENCH
- 7/16" SOCKET WRENCH
- 7/16" COMBINATION WRENCH
- ELECTRIC DRILL

ASSISTANCE

We recommend two people perform the installation as items are heavy and may need to be held in place while installing.

ORGANIZATION

Disassemble the vehicle where you can catalog and store everything. We suggest labeling and bagging all the OEM bolts when removing from the vehicle. Failure to keep track of parts could lead to an inability to properly reinstall components.

HARDWARE KIT | 50385-HW

FAB FOURS IDENTIFICATION	COMPONENT DESCRIPTION	QTY
50385-HW	1/4" BOLT YELLOW ZINC STEEL	2
50385-HW	1/4" HEX NUT ZINC STEEL	2
50385-HW	1/4" FLAT WASHER ZINC STEEL	4
50385-HW	1/4" LOCK WASHER ZINC STEEL	2
50385-HW	M6 X 1.0, BLACK STAINLESS, BUTTON HEAD CAP SCREW	16
50385-HW	M6, STAINLESS STEEL FLAT WASHER	16
50385-HW	5/16"-18, BOLT, ZINC STEEL	2
50385-HW	5/16", FLAT WASHER, ZINC STEEL	4
50385-HW	5/16", LOCK WASHER, ZINC STEEL	2
50385-HW	5/16"-16, RIVET NUT, ZINC, STEEL	2
50385-HW	17/32" DRILL BIT	1
50385-HW	5/16" RIVET NUT INSTALL TOOL	1

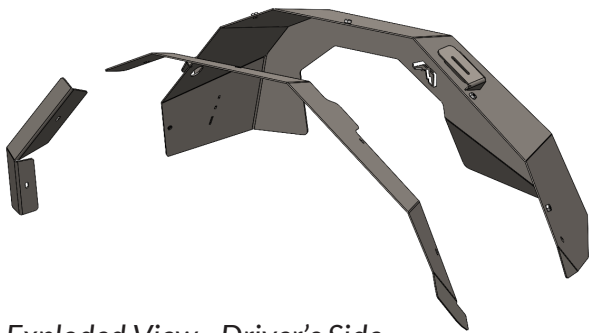

Exploded View - Driver's Side

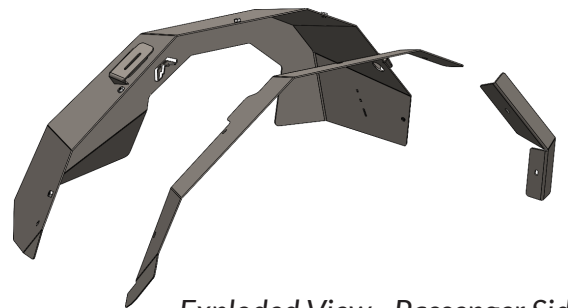

Exploded View - Passenger Side

DISASSEMBLY

1. Remove factory fender flares by turning plastic levers and pulling off flares. (Figure 1)



Figure 1

2. Using pop rivet removal tool and Phillip's head screwdriver, remove plastic push rivets from inner fender, and use 7mm socket to remove remaining sheet metal screws from inner fender.

3. Using 13mm socket, remove three (3) OE Bolts from plastic block inside wheel well and remove block. (Figure 2) Save one of these bolts per side for later use.



Figure 2

-
4. Gently pull front valence from plastic clips on both sides of vehicle. (Figure 3)



Figure 3

5. Fully remove front valence from vehicle by gently pulling it loose from center clips.
6. Locate small hole in front bar of vehicle. Use 17/32" drill bit (50385-HW) to enlarge hole. (Figure 4)



Figure 4

INSTALLATION

7. Insert 5/16" rivet nut (50385-HW) into hole. Follow instructions on Rivet nut installation tool to secure rivet nut into hole.
8. Using OEM bolt removed in step 3, install 22997 DS rear mount bracket, into outside TOP hole where plastic block was removed. Do NOT tighten at this point. (Figure 5) NOTE: Fender shown as removed in figure 5. Installation can be done without removing fender.

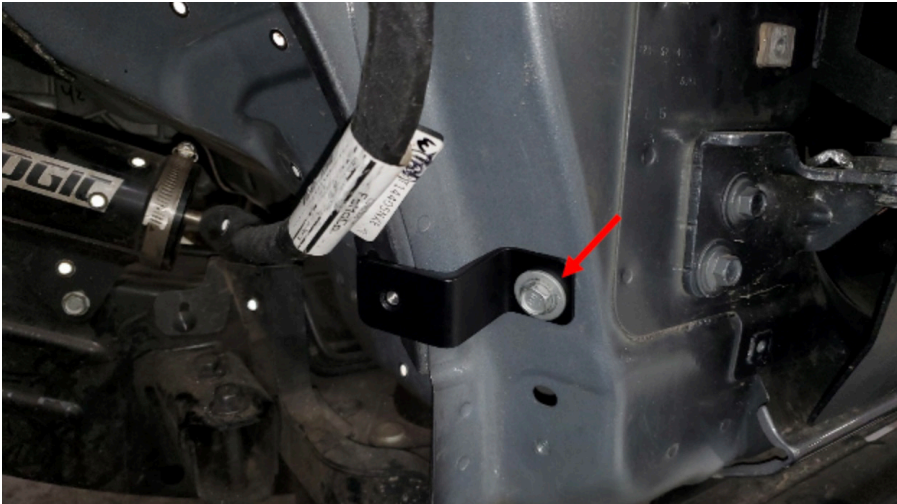

Figure 5

9. Place 22988 inner fender assembly into the wheel well. Start by inserting 5/16" bolt, flat washer, and lock washer into the top, front mounting point and into rivet nut installed in step 7. (Figure 6) Do not tighten at this time.



Figure 6

10. Install top mounting ¼" bolt, flat washers, lock washer and nut, through top slotted mount in inner fender and into mounting tab on vehicle (Figure 7 & 8). Do not tighten.

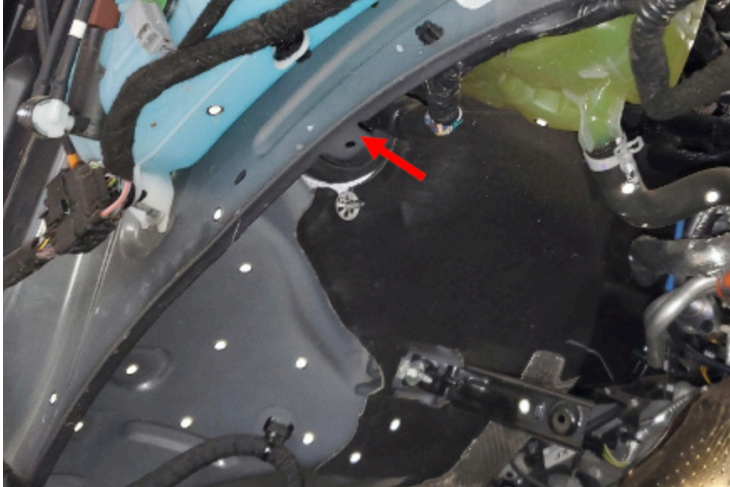

Figure 7



Figure 8

11. Install M6 cap head bolt and flat washer (50385-HW) into front lower mount through slot in body of vehicle. (Figure 9) Do not tighten.

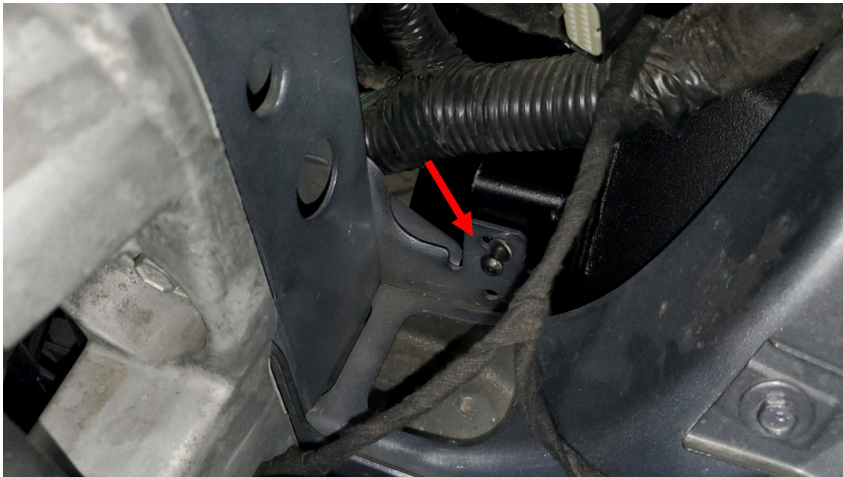

Figure 9

-
12. Install M6 cap head bolt and flat washer (50385-HW) through rear mounting slot and into 22997 bracket installed in step 8. (Figure 10)



Figure 10

13. Tighten all four (4) mounting bolts in order installed. Then tighten 22997 bracket mounting bolt into vehicle body panel.

14. Install 22989 front bolt on panel using two (2) M6 cap head bolts and flat washers (50385-HW). (Figure 11)

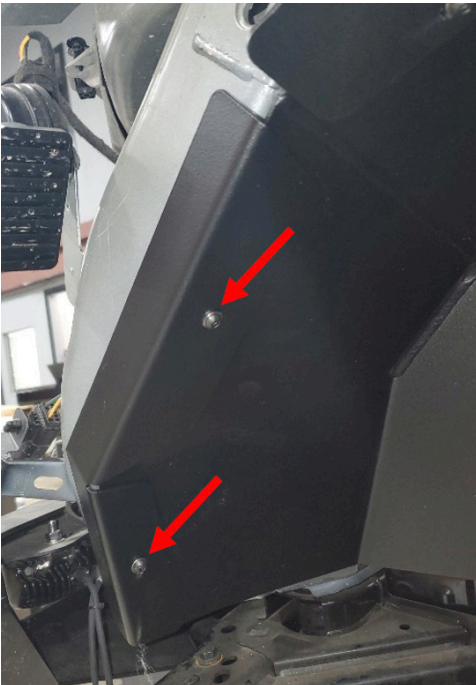

Figure 11

-
15. Install 22991 top bolt on panel using four (4) M6 cap head bolts and flat washers (50385-HW). (Figure 12) NOTE: If running Fab Fours FB2000 front fenders, skip this step.

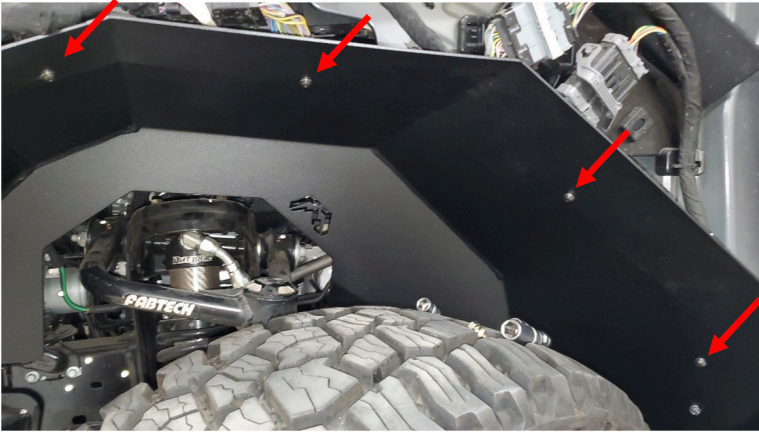

Figure 12

16. Reinstall OEM fender flare.
17. Repeat installation steps for passenger side inner fender.

INSTALLATION COMPLETE

CONTACT INFORMATION

**FAB FOURS INC.
2213 INDUSTRIAL PARK ROAD
LANCASTER, SC 29720**

PHONE: (866) 385-1905

FAX: 970-385-1914

EMAIL: SUPPORT@FABFOURS.COM

FABFOURS.COM



**“IF YOU’RE LOOKING FOR MORE OF THE SAME,
THEN YOU’VE COME TO THE WRONG PLACE.”**

- GREG HIGGS

