



Installation Instructions

Ford Raptor Front Winch Bumper

Product Number: H1961, H1960, H1962
Application: 2010+ Ford SVT RAPTOR

SAFETY

Your safety and the safety of others is very important.

- In order to help you make informed decisions about safety, we have provided installation instructions and other information.
- These instructions alert you to potential hazards that could hurt you or others.
- Please do a job safety analysis (JSA) before each task to identify potential hazards for your situation and remove/protect against them.
- You must use your own good judgment, and take your time.

Read and understand all safety precautions and instructions before installing this product.

THIS PRODUCT IS FOR OFFROAD USE ONLY. ALL LIABILITY FOR INSTALLATION AND USE RESTS WITH THE OWNER.

CARELESS INSTALLATION AND OPERATION CAN RESULT IN SERIOUS INJURY OR EQUIPMENT DAMAGE.

Injury hazard

Failure to observe these instructions could lead to severe injury or death.

- Always** remove jewelry and wear eye protection.
- Always** use extreme caution when jacking up a vehicle for work. Set emergency brake and use tire blocks. Locate and use the vehicle manufacturers designated lifting points. Use jack stands.
- Always** use appropriate and adequate care in lifting components into place.
- Always** insure components will remain secure during installation and operation.
- Always** wear safety glasses when installing this kit. A drilling operation will cause flying metal chips. Flying chips can cause serious eye injury.
- Always** use extreme caution when drilling on a vehicle. Thoroughly inspect the area to be drilled (on both sides of material) prior to drilling, and relocate any objects that may be damaged.
- Always** use extreme caution when cutting and trimming during fitting.
- Always** tighten all nuts and bolts securely per installation instructions.
- Always** route electrical cables carefully. Avoid moving parts, components that become hot and rough or sharp edges.
- Always** insulate and protect all exposed wiring and electrical terminals.
- Always** perform regular inspections and maintenance on mounts and related hardware.



Installation Instructions

Ford Raptor Front Winch Bumper

Product Number: H1961, H1960, H1962
Application: 2010+ Ford SVT RAPTOR

I. Overview

Congratulations on your new purchase of the industries' best and most stylish Front Winch Bumper available for the Ford SVT Raptor! This Bumper has been **engineered** for strength.

Your Front Bumper designed in 3-D from digitized data, CNC laser cut, fabricated, and powder coated... all in the U.S.A.

Enjoy the fit and finish of a quality Ford SVT Raptor Front Winch Bumper from Fab Fours Inc.

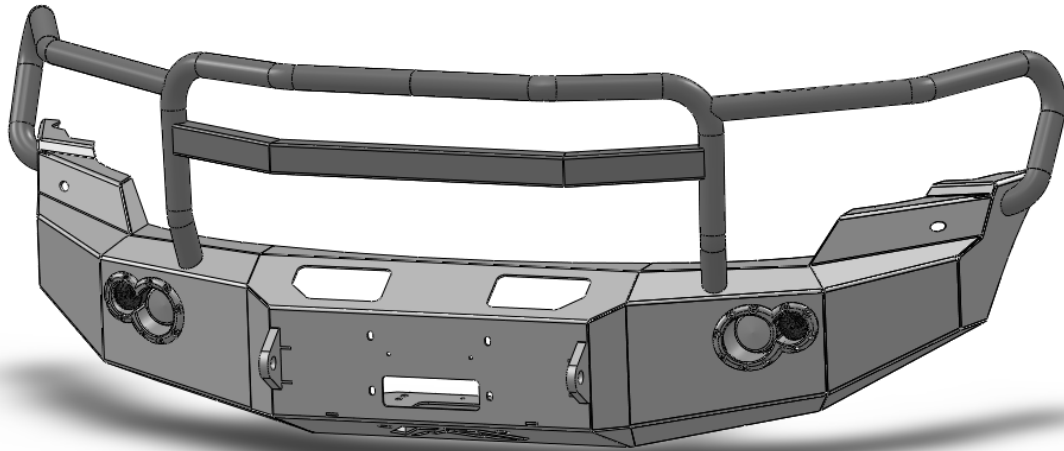



Installation Instructions















Ford Raptor Front Winch Bumper

Product Number: H1961, H1960, H1962
Application: 2010+ Ford SVT RAPTOR

II. Tools Required

- Socket Wrench with Extension
- Breaker Bar
- 3/4" , 8mm, 10mm, 15mm, and 21mm Sockets
- 5/32" & 1/8" Allen Keys
- Flat and Phillips Head Screw Drivers
- 3/4", 7/16", & 3/8" Open End Wrench
- Floor Jack and wood block.

III. Kit Contents

	QTY	DESCRIPTION	FAB FOURS PART NUMBER
	x 1	Ford Raptor Front Bumper	H196X
	x 1	Ford F150 Driver Mounting Bracket	20362
	x 1	Ford F150 Passenger Mounting Bracket	20363
	x 2	Nut Strip Backer Plate	20362-03
	x 2	Skid Plate Relocation Bracket	20364-20
	x 1	Driver Fog Light Mounting Bracket	20318-08
	x 1	Passenger Fog Light Mounting Bracket	20318-09
	x 2	Fab Fours Fog Light	61349
	x 2	Fab Fours Running light, Turn indicator	61350
	x 4	Stud Plate	20296
	x 1	HDLA Hardware Kit	HDLA-HW
	x 1	H19XX Hardware Kit	H19XX-HW
	x 1	H196X Instruction Manual	H196X-IM
	x 1	Hella Fog Light Harness	H84994031



Installation Instructions

Ford Raptor Front Winch Bumper

Product Number: H1961, H1960, H1962
Application: 2010+ Ford SVT RAPTOR

IV. Included Hardware

H196X-HW

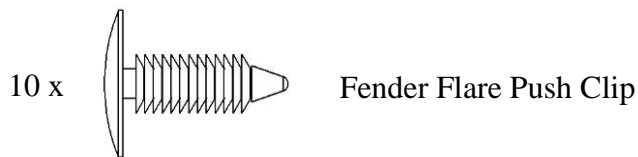
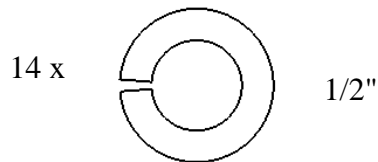
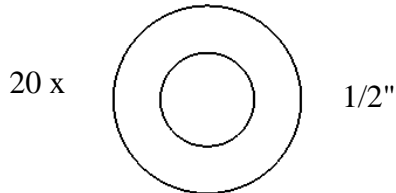
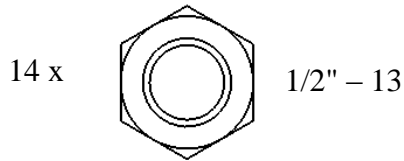
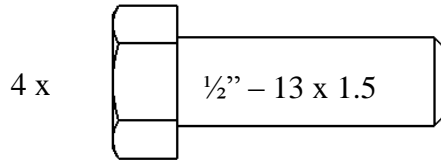

HDLA-HW

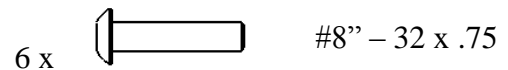
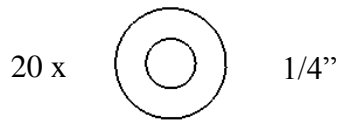
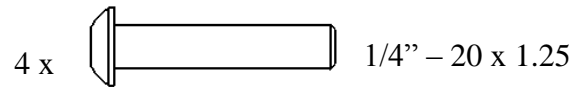
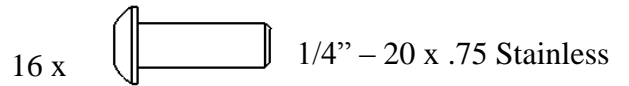
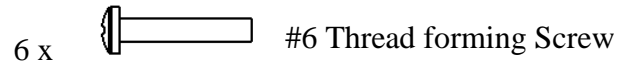



Installation Instructions

Ford Raptor Front Winch Bumper

Product Number: H1961, H1960, H1962
Application: 2010+ Ford SVT RAPTOR

V. Removal of Stock Bumper

1. From underneath the front of the truck, remove the six (6) fasteners attaching the OEM skid plate to the truck with a 15mm socket; See below:

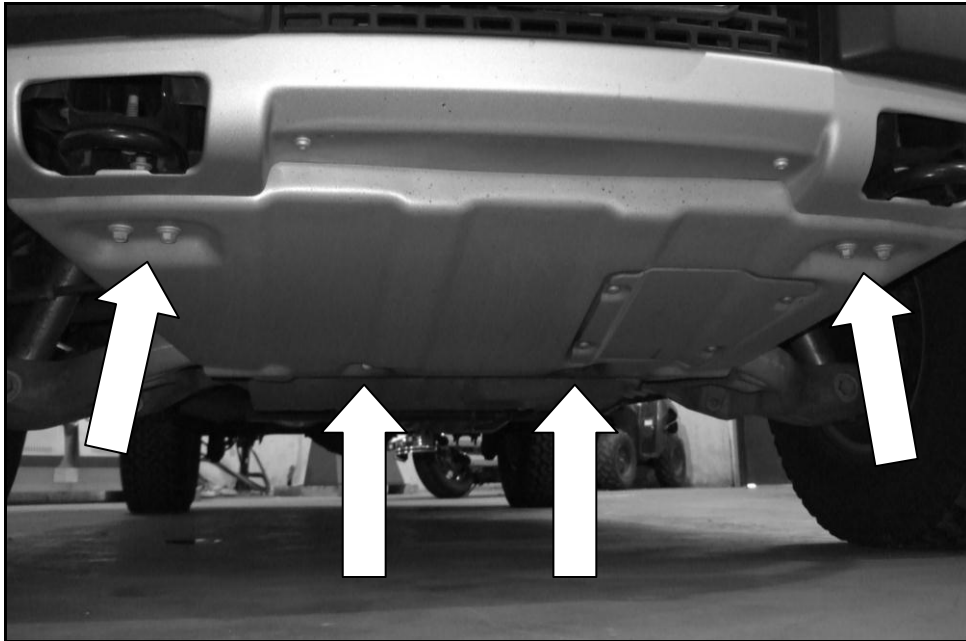

Figure 1 - SKID PLATE FASTENER LOCATION

2. Remove the OEM skid plate brackets from the bottom of the frame rail by removing one (1) fastener per side with a 15mm socket

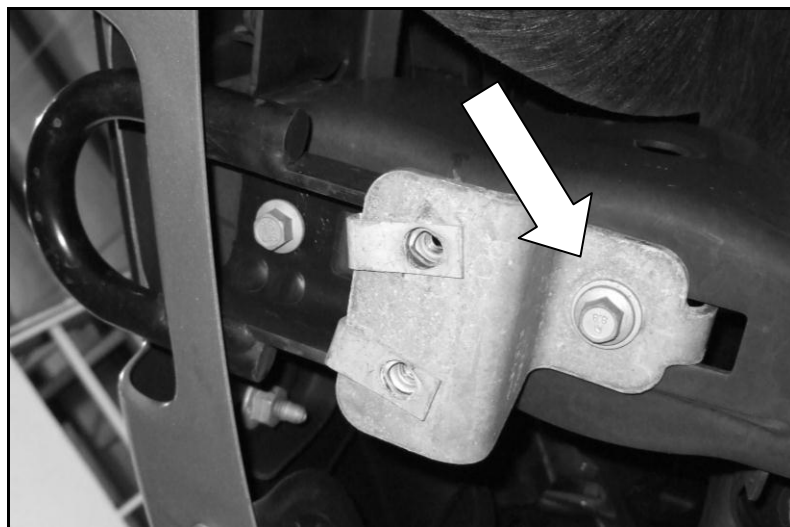

Figure 2 - SKID PLATE BRACKET REMOVAL



Installation Instructions

Ford Raptor Front Winch Bumper

Product Number: H1961, H1960, H1962
Application: 2010+ Ford SVT RAPTOR

3. Remove plastic push clips attaching the splash mat to the OEM bumper.
4. Remove the hood release retainer bolt with a 10mm socket:

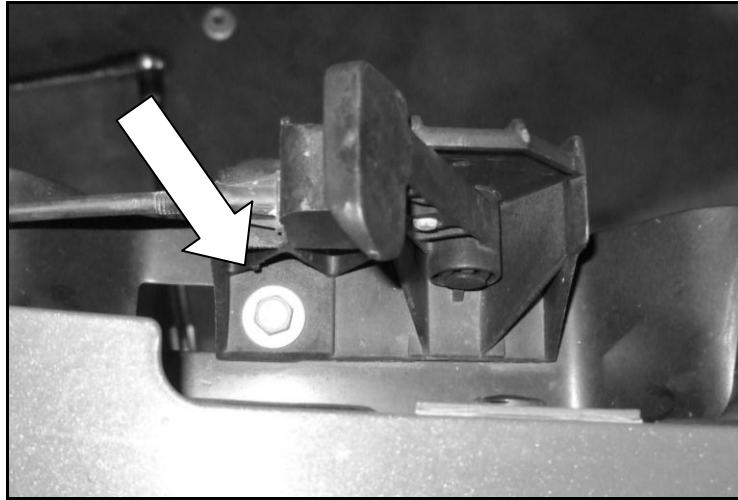

Figure 3 – HOOD RELEASE FASTENER LOCATION

5. Remove 2 bolts holding the center section of the plastic valence using a 10mm socket or wrench. See Image Below.

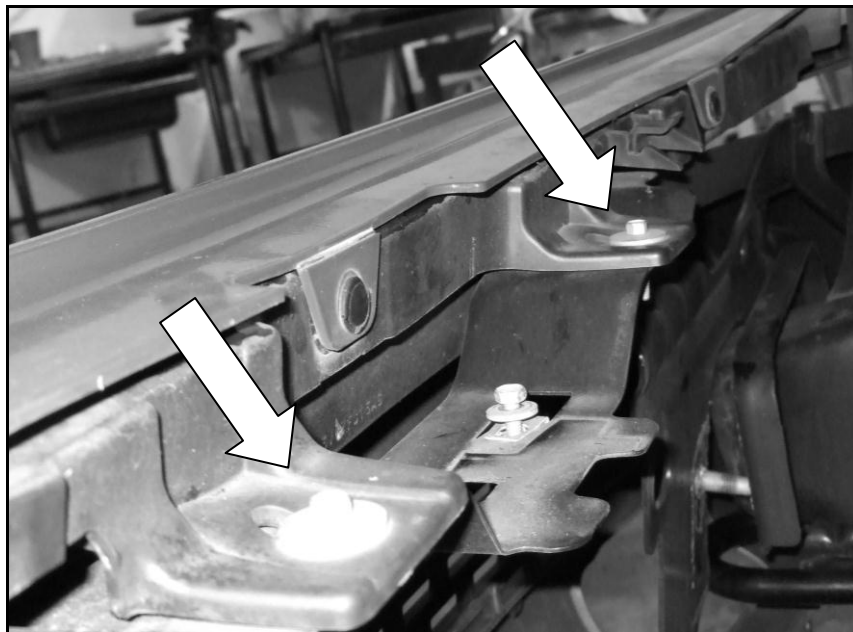

Figure 4 - CENTER VALENCE FASTENERS

6. Remove the 4 nuts (2 per side) holding the front bumper to the frame ends using a 21mm socket.



Installation Instructions

Ford Raptor Front Winch Bumper

Product Number: H1961, H1960, H1962
Application: 2010+ Ford SVT RAPTOR

- Using two people remove the metal portion of the bumper from the front of the vehicle.
- Remove the tow hooks from either side of the frame using a 15mm socket; save the screws and stud plates for later reuse.
- Remove the four (4) plastic push clips from the inner edge of the fender flare and 1 from the rear corner under the front of the door.
- Starting at the rear of the flare, pull upward and outward away from the truck to remove the fender flare:

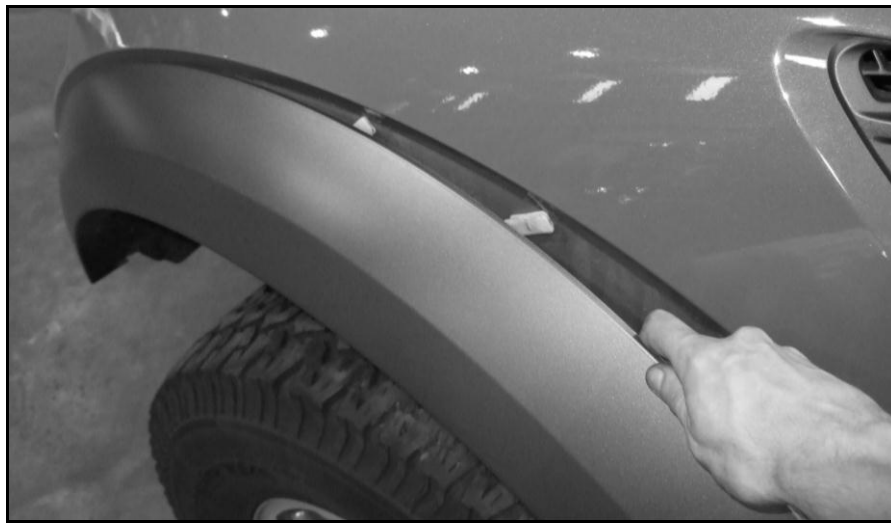

Figure 5 - FLARE REMOVAL

- Remove the front lower fender liner screw with a 5.5mm socket to access the front most clips from the back side. Depress the clips to fully remove the flare:

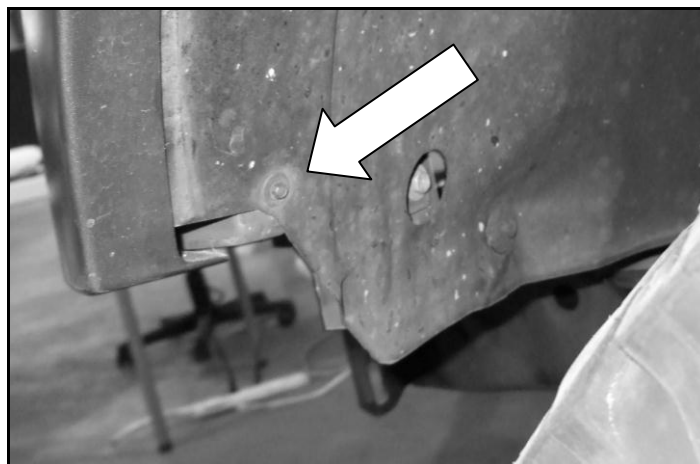

Figure 6 - FENDER LINER SCREW

12. Remove the fender flare clips that have remained in the fender by pulling outward and depressing the tab edges with a small pick as shown below:



Figure 7 - FLARE CLIP REMOVAL

13. Remove the 4 bolts per side from the fender well opening going up through the painted plastic valance and into the fender using a 10mm socket and extension. See below for hidden fastener location:

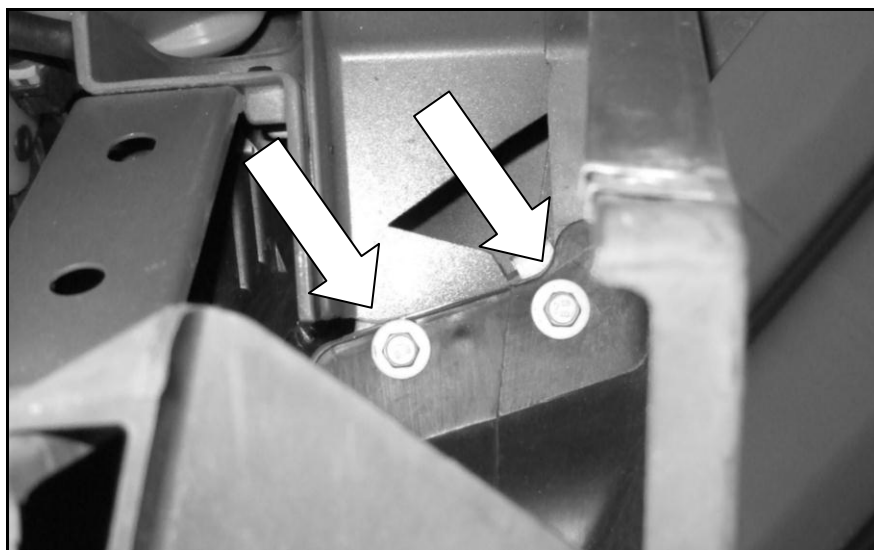

Figure 8 - INSIDE FASTENER LOCATION - VIEW FROM BELOW - INSIDE WHEEL WELL



Installation Instructions

Ford Raptor Front Winch Bumper

Product Number: H1961, H1960, H1962
Application: 2010+ Ford SVT RAPTOR

14. Unplug the wiring harness to the marker lights on each corner of the valence.
15. With a 10mm socket and wrench, remove the three (3) fasteners holding the headlight in place. Two (2) are located on top of the headlight and one (1) is on the inside front behind the splash mats.
16. Using a 10mm ratcheting wrench remove the two bolts holding the plastic painted valance sub-structure that were hidden by the headlights:

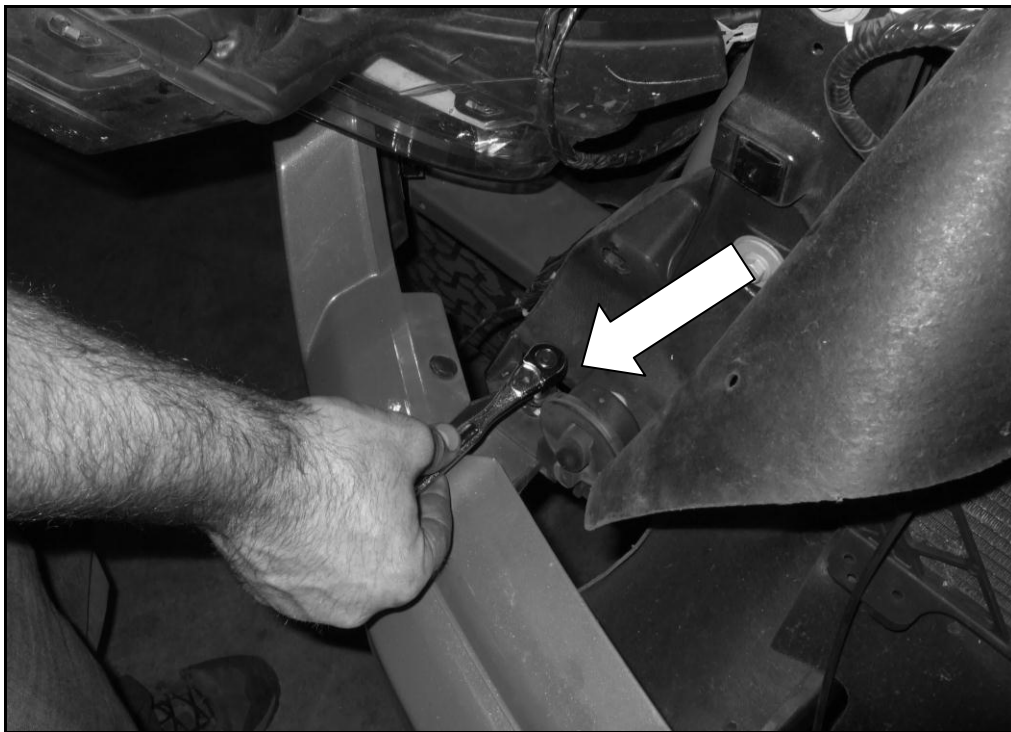

Figure 9 - UNDER HEADLIGHT FASTENER LOCATION

17. Remove the painted plastic valance by pulling outward and rotating away from the vehicle.
18. Temporarily reinstall the fender flares to mark them for trimming. Hold the flare in place and use painters tape to mark the intersection of the flare with the bottom of the fender.
19. With a tape measure, take a measurement from the ground to this mark. Use this measurement and more painters tape to mark a level line around the outside of the flare.
20. Step back from the truck and verify that the cut line looks level from both the side and front of the truck. Adjust the tape line if necessary.



Installation Instructions

Ford Raptor Front Winch Bumper

Product Number: H1961, H1960, H1962
Application: 2010+ Ford SVT RAPTOR

21. Mark a cut line on the inside of the fender flare that runs below the fastening hole slightly below the cut line as shown below:

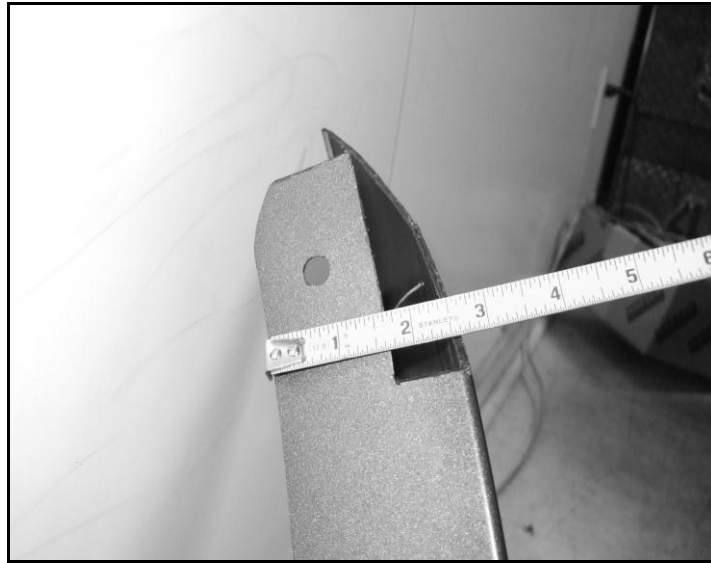

Figure 10 - FENDER FLARE INNER FACE TRIM LINE

22. Trim along the line with a rotary tool. **USE EXTREME CAUTION WHEN PERFORMING ANY CUTTING OPERATION.** Use a fine file to smooth the cut edge after cutting is complete. Properly trimmed flares should reinstall as shown below:

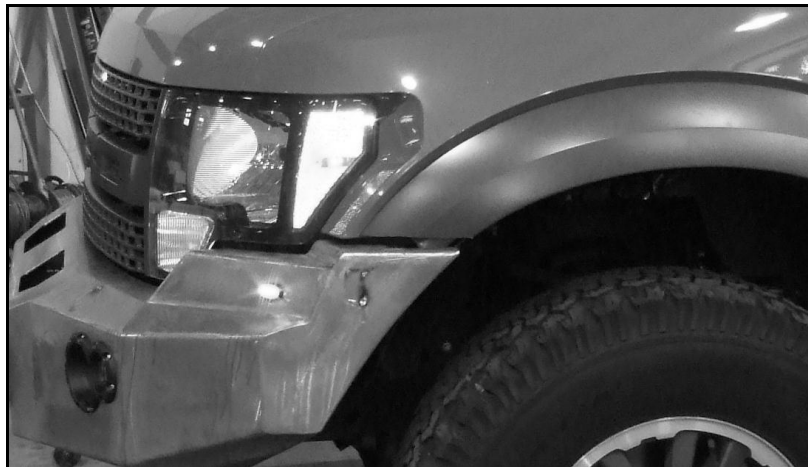

Figure 11 - COMPLETED FENDER TRIMMING

Your Truck is now ready for the install of your new Fab Fours Front Bumper!



Installation Instructions
Ford Raptor Front Winch Bumper
 Product Number: H1961, H1960, H1962
 Application: 2010+ Ford SVT RAPTOR

VI. Lights and Wiring Installation

1. With the headlights removed, tap into the turn indicator wiring with the supplied tap connectors.
2. The turn indicator wiring harness may be installed at this time. To do so, remove the wiring harness and bulb socket from the lens housing. See below for wire color guide.

WIRE COLORS:

<u>WIRE</u>	<u>OEM COLOR</u>	<u>FAB FOURS COLOR</u>
Running	Purple	→ White
TURN SIGNALS	Blue (Driver)	→ Red
	Yellow (Passenger)	
Ground	Black	→ Green

3. Tuck the Fab Fours provided wiring and bulb out of the way until the installation of the Fab Fours bumper is complete.
4. Replace headlights in reverse order of removal. Be sure to rout newly installed Fab Fours wiring away from sharp edges down to the bumper area.
5. Install the included Hella Fog Light Harness following the instructions supplied in the Hella Packaging.
6. Tuck OEM fog light harness and Fab Fours supplied wiring out of the way until completion of the bumper installation.

7. Install turn indicators into the plastic light insert using three self-tapping screws as shown below:

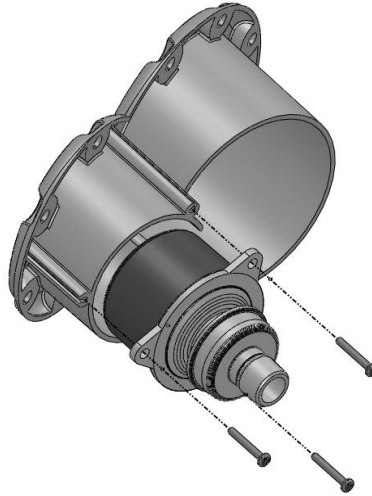

Figure 12 – Turn Signal Installation

8. Install the light inserts with turn indicators into the cutout in the bumper. Use the $\frac{3}{4}$ " length $\frac{1}{4}$ " stainless steel button head, $\frac{1}{4}$ " washers and hex nuts to fasten the insert through the holes shown below. Do not use the two holes closest to the center of the bumper at this time. Use washers only on the nut side (inside the bumper). Use needle nose pliers to tighten nuts with limited access.

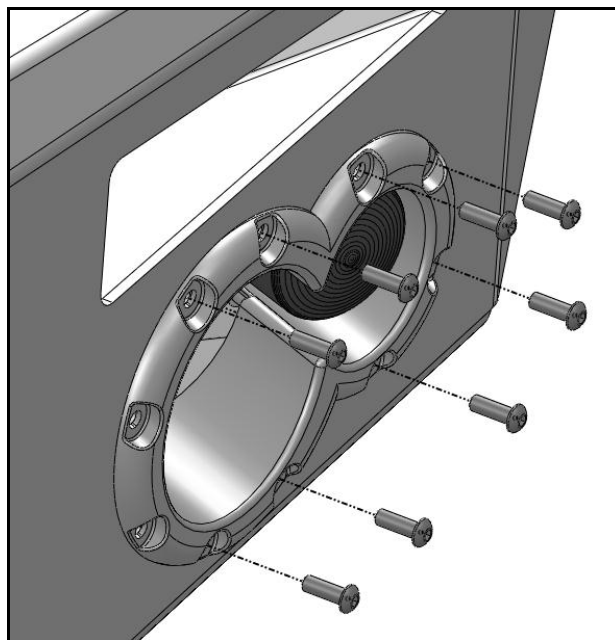

Figure 13 – Light Insert Installation



Installation Instructions

Ford Raptor Front Winch Bumper

Product Number: H1961, H1960, H1962
Application: 2010+ Ford SVT RAPTOR

9. Install the Fab Fours fog lights onto the mounting brackets as shown below using the #8 button head screws, washers, and nylock hex nuts.

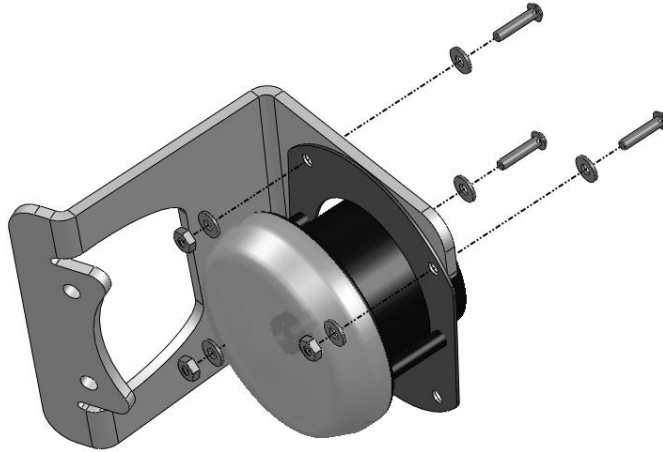

Figure 14 - Fog Light to Bracket Installation

10. Install the fog light and bracket into the bumper using the remaining two holes available in the light insert. Use the 1-1/2" length 1/4" stainless steel button heads with 1/4" washers and nylock nuts:

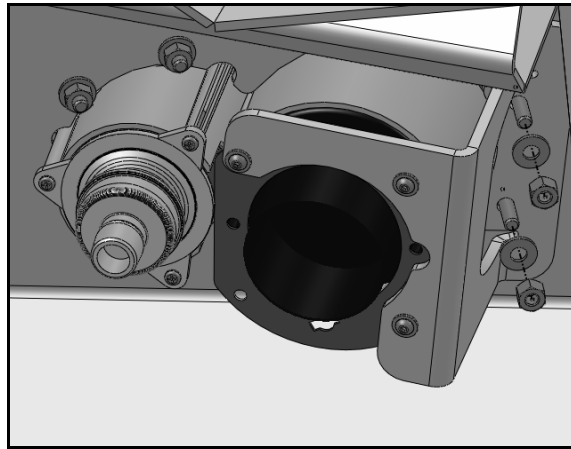

Figure 15 - Fog Light Installation

11. Repeat steps 7-10 for other side.

- ❑ **Do not connect wiring harnesses to lights until bumper is installed.**



Installation Instructions

Ford Raptor Front Winch Bumper

Product Number: H1961, H1960, H1962
Application: 2010+ Ford SVT RAPTOR

VII. Front Winch Bumper Installation

- **Optional:** If installing winch and roller fairlead into bumper, the winch must be placed into the bumper before installation on the vehicle. To ease the installation of the bumper, loosely install the winch at this time; it will later be moved to increase accessibility of bumper mounting fasteners. Always follow the winch manufacturer's instructions for final installation. If you are installing a winch with a pulling capacity of 12,000 lbs., the front face mounting holes must be used.

If not installing a winch, a license plate may be installed onto the front face of the bumper (Hardware not included).

1. Install the intermediate mounts onto the bumper using the provided stud plates, washers, lock washers, and nuts. The stud plates should face the inside of the truck for ease of tightening. See below:

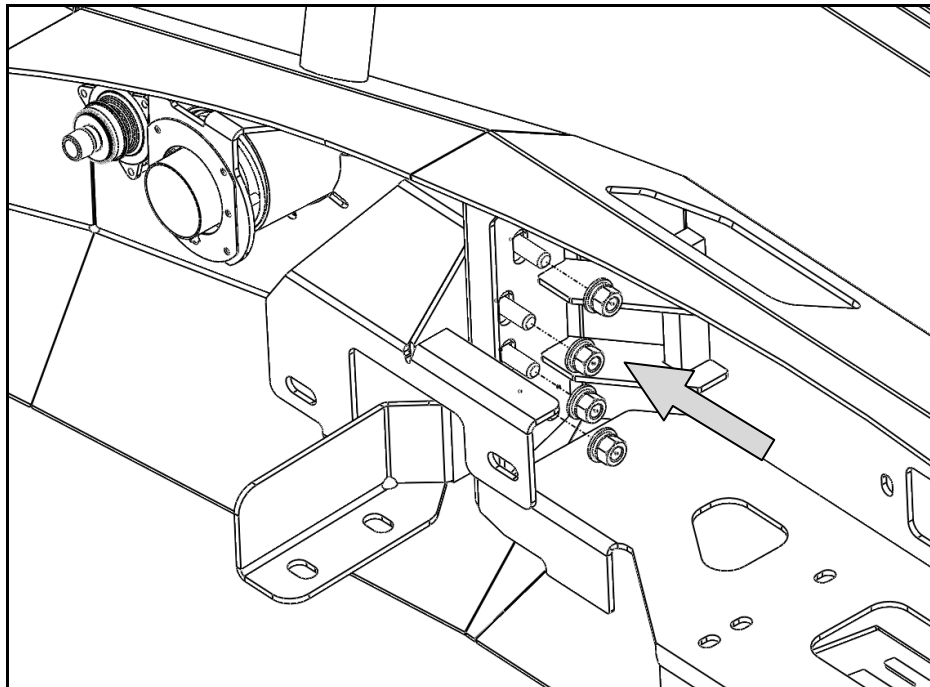

Figure 16 – INTERMEDIATE BRACKET INSTALLATION – TOP VIEW

2. Slide the bracket all the way to the top of its adjustment and snug one nut per side to keep the bracket in place.



Installation Instructions

Ford Raptor Front Winch Bumper

Product Number: H1961, H1960, H1962
Application: 2010+ Ford SVT RAPTOR

3. Temporarily affix the OEM tow hook nut plates to the provided backing plate with masking tape, then attach the nut plate with backer plate to the inside of the frame mount as shown below as access to this area will be difficult once the bumper has been placed on the truck.

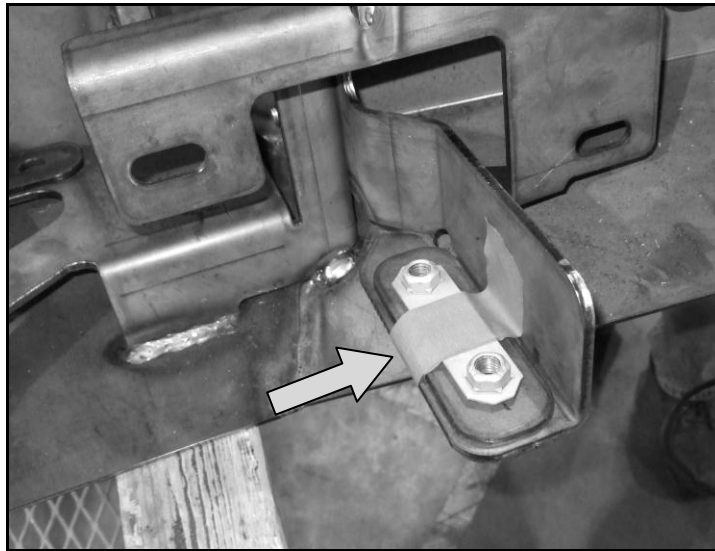

Figure 17 – OEM NUT PLATE PRE-INSTALLATION

4. With the help of a lifting device such as a crane or floor jack, or with the help of multiple assistants, lift the bumper and align with the frame flanges, inserting the end of the intermediate bracket into the open portion of the frame rail

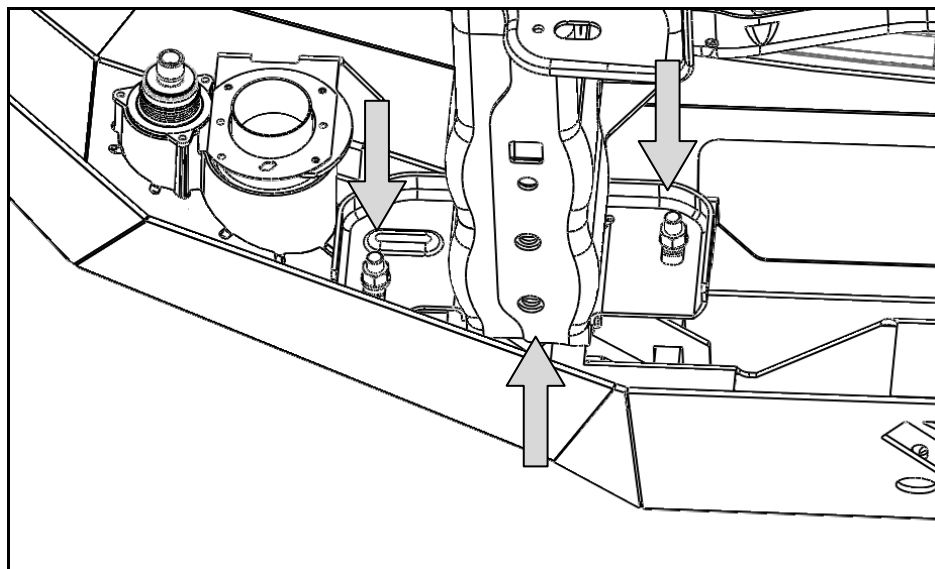

Figure 18 – FRAME FASTENER INSTALLATION LOCATION



Installation Instructions

Ford Raptor Front Winch Bumper

Product Number: H1961, H1960, H1962
Application: 2010+ Ford SVT RAPTOR

5. Loosely install the provided $\frac{1}{2}$ "x1.5" bolts through the slots in the frame flange and intermediate bracket. Reinstall the OEM tow hook screws into the OEM stud plate on the inside of the frame rail. Do not fully tighten these fasteners at this time.
6. Adjust the bumper to achieve good visual alignment side to side with equal gaps at each fender. Fully tighten the $\frac{1}{2}$ " bolts in the frame flanges with $\frac{3}{4}$ " socket and wrench and then fully tighten the OEM tow hook bolts with a 15mm socket.
7. If a winch is installed in the bumper, loosen it at this time to allow it to move side to side within the bumper. **CAUTION: DO NOT MOVE THE WINCH REARWARD IN THE BUMPER.** Doing so can cause the winch to fall and severely damage the truck's cooling system and pose an extreme injury risk for those working on the bumper. Only move the winch from side to side, keeping it in contact with the mounting faces at all times.
8. Lift the bumper to achieve good visual alignment underneath the headlights and fenders. Once desired alignment is attained, fully tighten the bracket to bumper fasteners with a $\frac{3}{4}$ " socket.

NOTE: Fab Fours recommends a **MINIMUM** gap of $\frac{3}{8}$ " at the outer fenders and headlights to prevent paint damage in normal operation.

9. Remove the marker lights from the OEM bumper valence and reinstall them in the oval holes in the Fab Fours bumper:



Figure 19 - MARKER LIGHT REINSTALLATION



Installation Instructions

Ford Raptor Front Winch Bumper

Product Number: H1961, H1960, H1962
Application: 2010+ Ford SVT RAPTOR

10. Connect the OEM wiring harnesses to marker lights and the Fab Fours provided wiring to the fog lights and turn indicators as shown in wiring diagram.
11. Clip the splash mat to the holes provided in the winch mounting area. Depending on the type of winch you are using, slight trimming of the splash mat may be required.

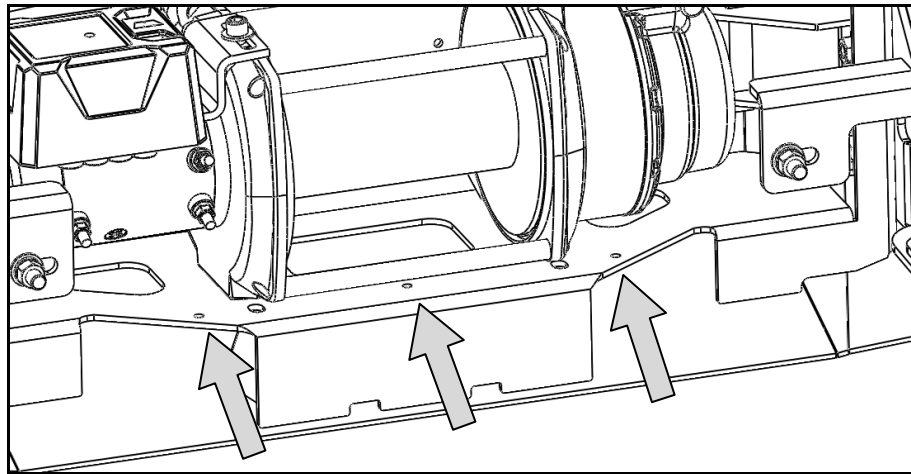

Figure 20 - SPLASH MAT CLIP LOCATION

12. Reattach the OEM clips into the trimmed fender flares. Reattach the flares to the truck, starting at the front (trimmed) edge.
13. Reinsert the plastic push clips into the mounting holes in the inner edge of the fender flares
14. Remove the spring nut from the OEM hood latch bracket and reinstall it on the Fab Fours bumper hood latch bracket. Use the OEM bolt to attach the hood latch lever to the bracket in the same orientation as the OEM installation.
15. Remove the spring nuts from the OEM skid plate bracket and affix them to the Fab Fours provided skid plate bracket in the same orientation.
16. Install the Fab Fours skid plate mounting brackets in the OEM location with the OEM hardware.
17. Reattach the skid plate to the truck with the six (6) OEM bolts and a 15mm socket.
18. Verify proper operation of lights. **Note:** Turn indicators should be dim during “running” condition and flash bright for turn.



Installation Instructions
Ford Raptor Front Winch Bumper
Product Number: H1961, H1960, H1962
Application: 2010+ Ford SVT RAPTOR

VIII. Maintenance/Care

- Periodically check and tighten all fasteners.
- Stripped, fractured, or bent bolts or nuts need to be replaced.
- After washing of the vehicle make sure to fully dry all surfaces

IX. Contact Information

Fab Fours Inc.
1312 Camp Creek Rd
Lancaster, SC 29720

Phone (866)-385-1905
Fax (866)-574-1424
Email Support@fabfours.com



More than expected... Better than expected