



[www.riderite.com](http://www.riderite.com)

Congratulations on your purchase of a new air spring spacer kit. Please take a few minutes to read through the instructions, identify the components, and learn how to properly install your air spring spacer kit. It is a good idea to start by comparing the parts in your kit with the parts list below. Be sure to take all the applicable safety precautions during the installation.

**Note: The vehicle reaction and handling characteristics may differ from standard vehicles. Modifications to improve and/or enhance off road performance may raise the center of gravity. Extreme caution must be utilized when encountering driving conditions which may cause vehicle imbalance or loss of control. Please Drive Safely! Avoid abrupt maneuvers, such as sudden sharp turns which could cause a roll over, resulting in serious injury or death.**

### **STEP 1**

Assembly will begin with the left (driver's) side of the vehicle. All pictures and instructions depict the installation on the left side of the vehicle. Install the upper bracket of your Ride-Rite Air Helper Spring kit according to the kits installation instructions. Next, install the air spring spacer to the bottom of the air spring using the 3/8"-16 x 1" hex bolt and 3/8" lock washers out of the kit. Make sure that the sticker is installed towards the rear of the vehicle.

### **STEP 2**

Locate the 3/8"-16 x 1" bolts, 3/8" lock washers, and your lower bracket out of your Ride-Rite Air Helper Spring kit. Mount the lower bracket to the bottom of the spacer using 3/8"-16 x 1" bolt and 3/8" lock washer. Make sure to use Loctite® when installing these bolts

### **STEP 3**

Please refer back to your Ride-Rite Air Helper Spring installation manual to complete the lower bracket installation and to finish the installation of the kit.

### **STEP 4**

Follow Steps 1-3 for the assembly and installation of the right, or passenger's side assembly.

## **PARTS LIST**

---

AIR SPRING SPACER	2
3/8"-16 X 1" BOLT	8
3/8" LOCK WASHER	8

---

## SPACER INSTALLATION

FOR UPPER BRACKET INSTALLATION AND COMPLETE KIT INSTALLATION, PLEASE REFER TO THE RIDE-RITE AIR HELPER SPRING INSTALLATION INSTRUCTIONS.

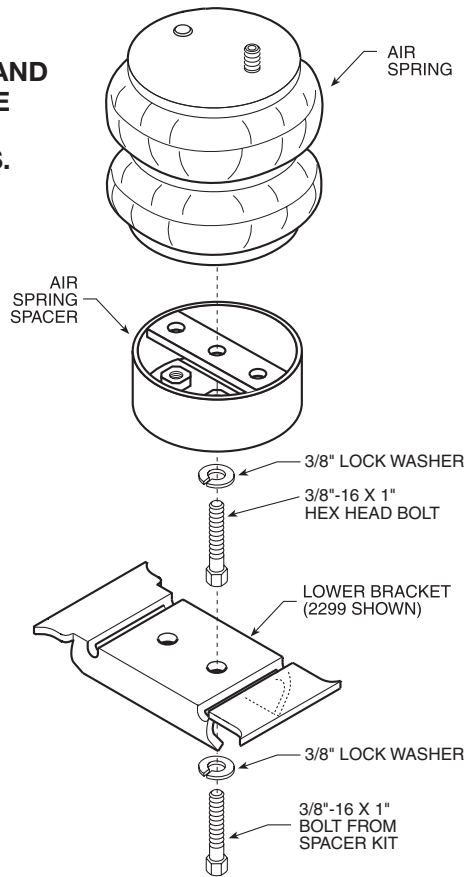
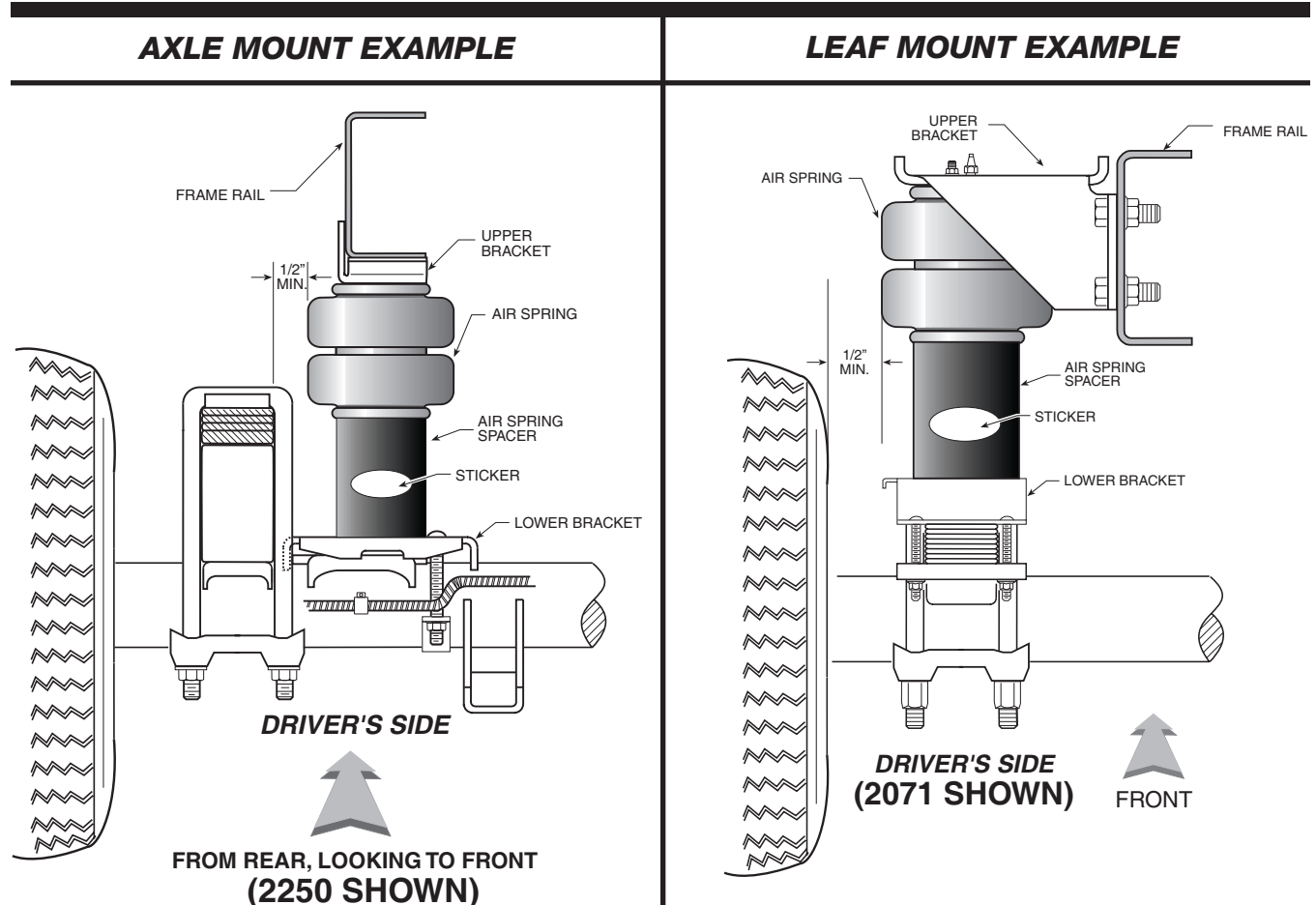

FIGURE "A"

(2299 SHOWN)

**Note:** Check to be sure that there is proper clearance around the air springs. With a load on the vehicle and the air helper springs inflated, there must be at least 1/2" clearance around the air springs.





# Do Not Return This Product to the Dealer or Distributor

## If you are

- missing parts,
- experiencing installation problems, or
- have technical concerns regarding this product,

you may contact a Firestone Technical Service Representative at [rrtech@fsip.com](mailto:rrtech@fsip.com) or at 800-888-0650 (option 1, and then option 2). Representatives are available from 7:30 a.m. – 4:30 p.m. Eastern on Monday – Friday, excluding holidays. If you are located outside of the United States, you should first contact your distributor or dealer directly with any issues.

When contacting Technical Service, please have the kit or part # ready, along with the make, model, and year of the vehicle. You may also need to provide details, such as 2WD/4WD or if the vehicle has been lifted or lowered from stock height.

If you have a warranty concern, please include in your email a detailed description of the situation, a photo(s) of the issue, and your contact information, including ship-to address.

**WARRANTY COVERAGE\***— The Ride-Rite™ kits, components, and accessories are warranted against defects in workmanship and materials. This warranty does not cover service or labor charges, neglect...to the product.

### **PERIOD OF COVERAGE:**

- |   |  |
|---|--|
| • Ride-Rite air springs – Lifetime Limited  | • Work-Rite load assists – 2 Years Limited                                       |
| • Sport-Rite air springs – Lifetime Limited | • Air-Rite accessories – 2 Years Limited   |
| • Coil-Rite air springs – Lifetime Limited  | • Brackets, hardware, fittings, air line, and other components – 2 Years Limited |
| • Level-Rite air springs – Lifetime Limited |  |

**HOW TO MAKE A WARRANTY CLAIM** — If you purchased your air springs in the U.S. or Canada and believe you have a part with a warrantable defect, call Firestone directly at 1-800-888-0650.

International customers should contact their distributors or dealers directly with any problems.

(\*) Please refer to the “Firestone Limited Lifetime Air Spring Warranty” for details, terms, and conditions.

## **WARRANTY QUESTIONS**

Go to [www.riderite.com/installation-support](http://www.riderite.com/installation-support)  
Select “Warranty Info” tab