

Light Duty Electronic Air Command™

INSTALLATION INSTRUCTIONS

Congratulations on your purchase of a Light Duty Electronic Air Command™ kit. This kit was designed to provide inflation control of your air helper springs. This kit will be an asset to your vehicle, meeting nearly all of your air supply needs.

Please take a few minutes to read through the instructions to identify the components and learn how to properly install your Light Duty Electronic Air Command™ kit.

NOTE:

The Light Duty Electronic Air Command™ kit can be used with all air helper spring products. If you are installing an air suspension system, do not install the air line tubing to the air springs as stated in the suspension system instruction manual. If you are adding the Light Duty Electronic Air Command™ kit to an existing air suspension system, you will need to deflate the air springs and remove the air line tubing.

NOTE ON CONNECTING AIR LINE TUBING

Cut the air line tubing as squarely as possible. To connect the air line tubing to the fittings, push the tubing into the fittings as far as possible. If for any reason the tubing must be removed, first release the air pressure from the air helper spring. Push the collar towards the body of the fitting and then pull out the tubing. To reassemble, make sure the tubing is cut squarely and push the tubing back into the fitting.

TOOLS REQUIRED:

CENTER PUNCH	3/16" DRILL BIT
9/32" DRILL BIT	3/8" DRILL
WIRE CRIMPERS	3/8" WRENCH
1/2" WRENCH	5/8" WRENCH
7MM WRENCH	PHILLIPS SCREWDRIVER

PARTS LIST

GAUGE PANEL	9369	1	1/4" FLAT WASHER	4
AIR COMPRESSOR	9377	1	1/4"-20 X 2-1/2" HEX HEAD BOLT	2
VALVE BLOCK	9357	1	10/32" X 3/4" MACHINE SCREW	1
PRESSURE SENSOR	9054	2	10/32" X 1" MACHINE SCREW	4
WIRE HARNESS	9371	1	1/4"-20 NYLOCK NUT	2
AIR LINE	0938	1	10/32" NYLOCK NUT	5
MALE FITTING	3055	1	VELCRO TABS	4
TEE FITTING	3025	2	NYLON TIE	15
3/16" FLAT WASHER		9		

Air Line & Wiring Diagram

Figure "A"

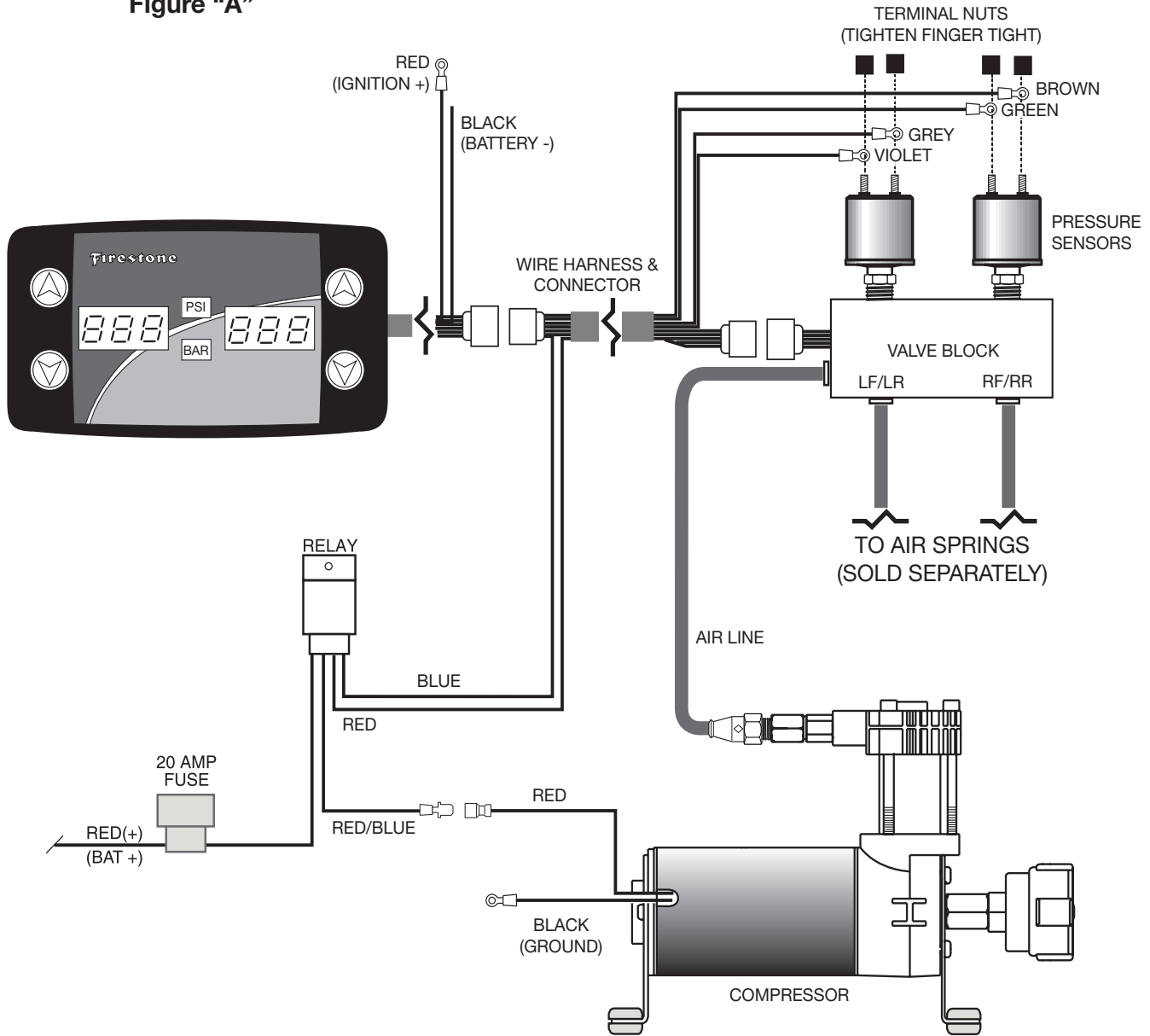

System Operation

Push the up or down button to set the air springs to the desired pressure. After the button is released, the system will inflate or deflate to the set pressure. The system may make periodic adjustments to maintain the set pressure. The system will not deflate below 5 PSI and will not inflate past 120 PSI. If the system pressure is above or below these levels, a warning will be displayed. To change the display values from PSI to BAR, or BAR to PSI, press and hold both the up and down buttons, on the right side, at the same time.

STEP 1—MOUNT THE COMPRESSOR

Begin by removing the negative battery cable. Select a convenient location to mount the compressor. This location should provide ample air flow and be protected from airborne debris and moisture. The mounting surface should be rigid to support the compressor. The compressor is oil-less and can be mounted in any orientation necessary for installation. Make sure that the wire harness will reach from the compressor to the anticipated location of the gauge panel. Install a male fitting into the threaded output port on the compressor head, *see Figure "A"*. Tighten the fitting sufficiently to engage at least two threads with the pre-applied thread sealant. **DO NOT OVERTIGHTEN THE FITTING.** Mark the four compressor mounting holes using the compressor as a template and a center punch, then drill four 3/16" holes. Mount the compressor using the supplied 10-32 x 1" machine screw, 10-32 nylock nuts and 3/16" washers. *See Figure "B"*. Attach the black wire from the compressor to a convenient ground source on the vehicle.

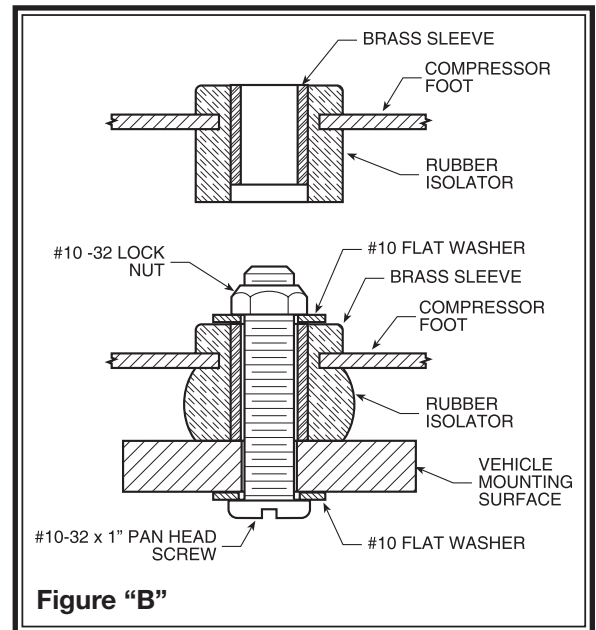

Figure "B"

STEP 2—MOUNT THE MANIFOLD BLOCK

Select the valve block from your kit and install the pressure sensors into the top of the valve block in the holes marked **PS1** and **PS2**. *See Figure "A"*. Select a convenient location to mount the valve block near the compressor. Mark the two mounting holes using the valve block as a template and a center punch, then drill two 9/32" holes. Mount the valve block using the supplied 1/4"-20 x 2-1/2" bolts and 1/4" nylock nuts.

STEP 3—WIRE HARNESS FROM THE COMPRESSOR AND VALVE BLOCK

Insert the red/blue wire from the wire harness with the male spade terminal into the female spade terminal on the red wire from the compressor. The other red wire in the wire harness with the fuse will be connected to a 12 Volt, 20 Amp positive power source. *See Figure "A"*. Attach the brown and green wires with ring terminals from the wiring harness to the studs on the pressure sensor in RF/RR, and the violet and grey wires with ring terminals from the wiring harness to the studs on the pressure sensor in LF/LR. Tighten the nuts on the pressure sensor terminals figure tight. **DO NOT OVERTIGHTEN THE TERMINAL NUTS.** *See Figure "A"*.

STEP 4—MOUNT THE GAUGE PANEL

The gauge panel must be mounted in a dry protected location with a flat mounting surface. Install the four Velcro tabs onto the back of the gauge panel and then firmly place the gauge panel onto the mounting location.

STEP 5—WIRE HARNESS FOR THE GAUGE PANEL

Connect the black wire from the gauge panel wire harness to a suitable ground and the red wire to 12V ignition activated source. Route the wire harness from the compressor and manifold block to the gauge. Use the Nylon ties provided to secure the wire harness to the vehicle. Route the wire harness to avoid direct heat from the exhaust system and away from any sharp edges. Insert the male connector into the female connector until a clicking noise is heard. *See Figure "A"*.

STEP 6—ROUTE THE AIR LINE

Cut a section of air line tubing that will reach from the compressor to the valve block. Cut the air line tubing as squarely as possible and insert the tubing into the male fitting on the compressor and then into the fitting on the valve block marked **IN**. Cut a section of air line tubing that will reach from the valve block to one of the air springs. Cut the air line tubing as squarely as possible and insert the tubing into the fitting on the valve block and then insert the other end into the air spring. Use the Nylon ties provided to secure the air line tubing to the vehicle. Route the tubing to avoid direct heat from the exhaust system and away from any sharp edges. Repeat this last step on the other air spring and remaining fitting.

STEP 8—CHECK THE SYSTEM

With the Light Duty Electronic Air Command™ kit and the air springs installed you are ready to test the system. Re-attach the negative battery cable. Turn on the vehicle's ignition. Push and hold the up button to inflate the air springs. The gauge will display how much air pressure is in the system. Inflate the air springs to 70 psi or the max air spring pressure, whichever is less, and check the fittings for air leaks with a solution of soap and water. If a leak is detected at a tubing connection, check to make sure that the tube is cut as squarely as possible and that it is pushed completely into the fitting. The tubing can easily be removed from the fitting by first releasing the pressure from the air spring, then by pushing the collar towards the body of the fitting and holding, then pulling the tube out.

TROUBLE SHOOTING THE SYSTEM

Display powers up but it will not inflate or deflate — The red power wire in the wire harness is not connected to the battery.

Both sides blink “Hi” & “150” repeatedly and will not inflate or deflate — Two of the wires for the pressure senders are switched. Gray and Violet go to the LF/LR sender. Brown and Green go to the RF/RR sender.

One side blinks “Hi” & “150” repeatedly and will not inflate or deflate but the other side works — One of the wires for the pressure sender on that side is not connected/making contact with the pressure sender.

The compressor runs continuously, while one side deflates and the other side does nothing, and the buttons on the controller do not respond — The colored wires on the pressure senders are connected to the wrong pressure sender. Gray and Violet go to the LF/LR sender. Brown and Green go to the RF/RR sender.





Do Not Return This Product to the Dealer or Distributor

If you are

- missing parts,
- experiencing installation problems, or
- have technical concerns regarding this product,

you may contact a Firestone Technical Service Representative at rrtech@fsip.com or at 800-888-0650 (option 1, and then option 2). Representatives are available from 7:30 a.m. – 4:30 p.m. Eastern on Monday – Friday, excluding holidays. If you are located outside of the United States, you should first contact your distributor or dealer directly with any issues.

When contacting Technical Service, please have the kit or part # ready, along with the make, model, and year of the vehicle. You may also need to provide details, such as 2WD/4WD or if the vehicle has been lifted or lowered from stock height.

If you have a warranty concern, please include in your email a detailed description of the situation, a photo(s) of the issue, and your contact information, including ship-to address.

WARRANTY COVERAGE*— The Ride-Rite™ kits, components, and accessories are warranted against defects in workmanship and materials. This warranty does not cover service or labor charges, neglect...to the product.

PERIOD OF COVERAGE:

- | | |
|---|--|
| • Ride-Rite air springs – Lifetime Limited | • Work-Rite load assists – 2 Years Limited |
| • Sport-Rite air springs – Lifetime Limited | • Air-Rite accessories – 2 Years Limited |
| • Coil-Rite air springs – Lifetime Limited | • Brackets, hardware, fittings, air line, and other components – 2 Years Limited |
| • Level-Rite air springs – Lifetime Limited | |

HOW TO MAKE A WARRANTY CLAIM — If you purchased your air springs in the U.S. or Canada and believe you have a part with a warrantable defect, call Firestone directly at 1-800-888-0650.

International customers should contact their distributors or dealers directly with any problems.

(*) Please refer to the “Firestone Limited Lifetime Air Spring Warranty” for details, terms, and conditions.

WARRANTY QUESTIONS

Go to www.riderite.com/installation-support
Select “Warranty Info” tab