



4 CORNER WIRELESS AIR COMMAND

INSTALLATION INSTRUCTIONS

Congratulations on your purchase of a Wireless Air Command kit. This kit was designed to provide inflation control of your air helper springs. This kit will be an asset to your vehicle, meeting nearly all of your air supply needs.

Please take a few minutes to read through the instructions to identify the components and learn how to properly install your Wireless Air Command kit.

NOTE:

The Wireless Air Command kit can be used with all air helper spring products. If you are installing an air suspension system, do not install the air line tubing to the air springs as stated in the suspension system instruction manual. If you are adding the Wireless Air Command kit to an existing air suspension system, you will need to deflate the air springs and remove the air line tubing.

NOTE ON CONNECTING THE AIR LINE TUBING

Cut the air line tubing as squarely as possible. To connect the air line tubing to the fittings, push the tubing into the fittings as far as possible. If for any reason the tubing must be removed, first release the air pressure from the air helper spring. Push the collar towards the body of the fitting and then pull out the tubing. To reassemble, make sure the tubing is cut squarely and push the tubing back into the fitting.

PARTS LIST

WIRELESS CONTROLLER	9367	1	1/4" FLAT WASHER	8
ECU	9366	1	3/16" FLAT WASHER	8
AIR COMPRESSOR	9377	1	1/4"-20 X 2-1/2" HEX BOLTS	4
VALVE BLOCK	9357	2	10/32" X 3/4" MACHINE SCREW	2
PRESSURE SENSOR	9054	4	10/32" X 1" MACHINE SCREW	4
AIR LINE	0938	1	10/32" NYLOCK NUT	6
MALE FITTING	3055	1	VELCRO TABS	4
TEE FITTING	3025	1	NYLONTIE	15

4 Corner System

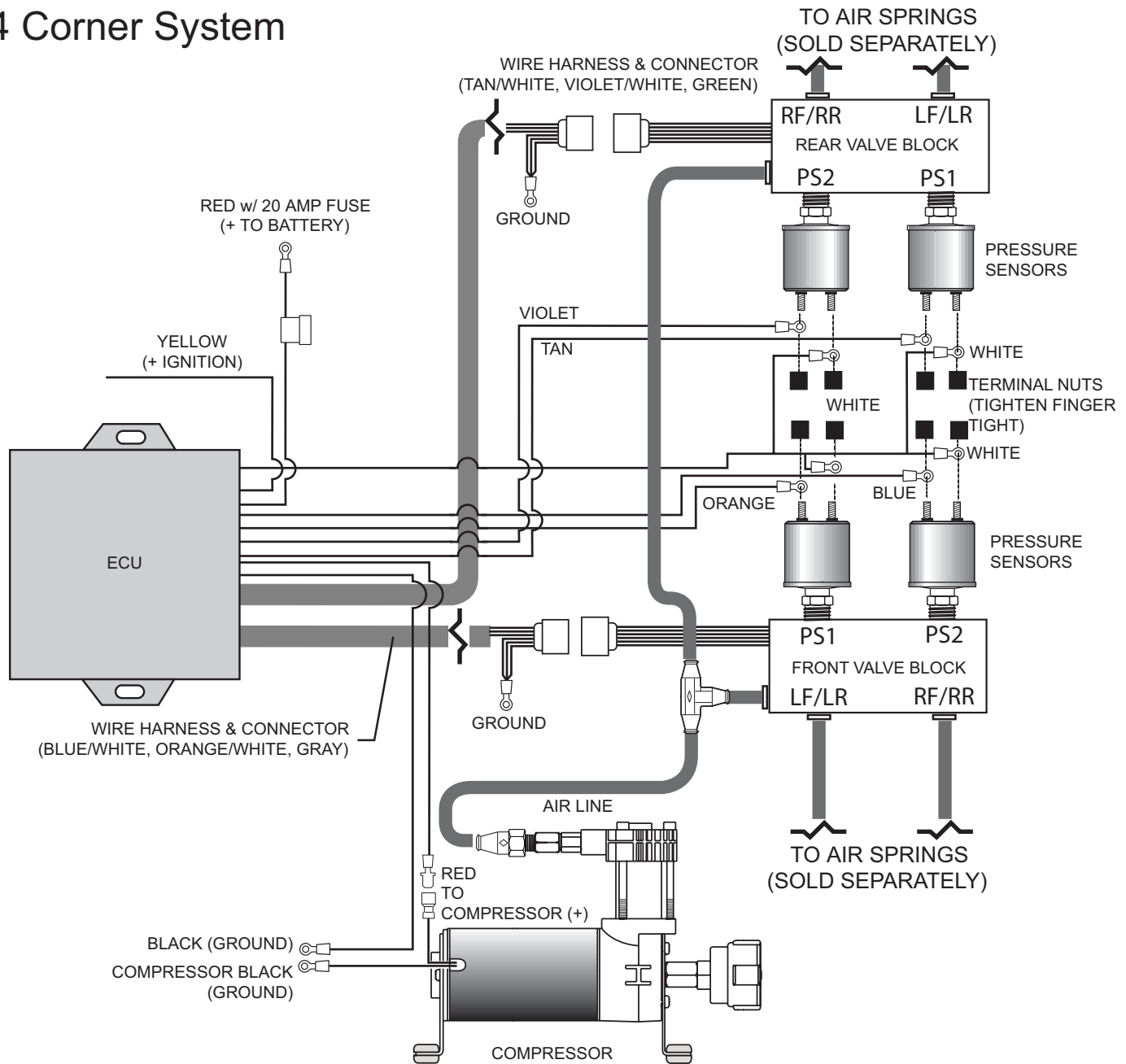

Press MODE Selection

- 1 Front Left (LF)
- 2 Front Right (RF)
- 3 Rear Left (LR)
- 4 Rear Right (RR)
- 5 Fronts (LF & RF)
- 6 Rears (LR & RR)
- 7 All corners (LF,RF,LR,RR)
- 8 Returns to (LF)

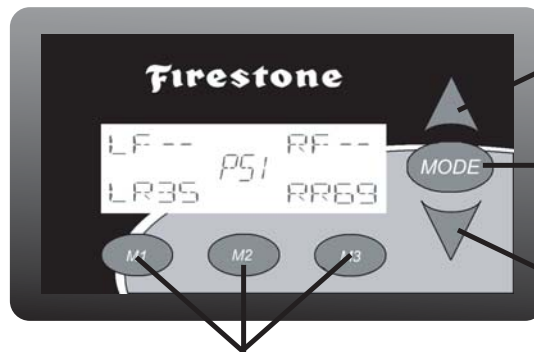

- UP ARROW**
INFLATES AIR SPRING(S)
- MODE** - CYCLES THROUGH AIR SPRINGS
- DOWN ARROW**
DEFLATES AIR SPRING(S)

MEMORY BUTTONS - DISPLAYS AND ADJUSTS TO PRESET PRESSURE IN THE AIR SPRING(S)

USING THE MEMORY KEYS

Once the vehicle has been leveled and the desired pressure set, the displayed pressures can be stored and retrieved using the three memory buttons. Hold one of the memory buttons down for three seconds and release. To recall the stored pressures, press the memory button once. To inflate/deflate to the stored pressures, press the same memory button again within five seconds.

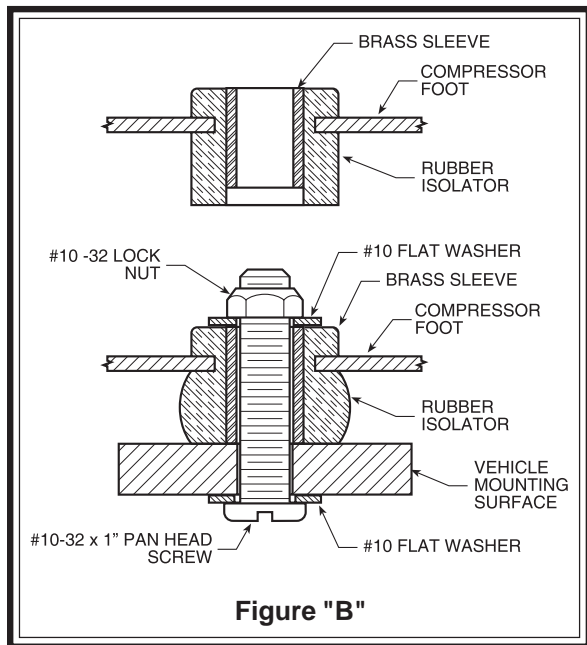

STEP 1 – MOUNT THE COMPRESSOR

Disconnect the negative battery cable. Select a convenient location to mount the compressor. This location should provide ample airflow and be protected from airborne debris. The mounting surface should be rigid to support the compressor. The compressor is oil-less and can be mounted in any orientation necessary for installation. Make sure that the wire harness will reach from the compressor to the anticipated location of the ECU. Install a male fitting into the treaded output on the compressor head, *see Figure "A"*. Tighten the fitting sufficiently to engage at least two threads with the pre-applied thread sealant. **DO NOT OVER TIGHTEN THE FITTING.** Mark the four compressor mounting holes using the compressor as a template and a center punch, then drill four 3/16" holes. Mount the compressor using the supplied 10-32 x 1" machine screw, 10-32 nylock nuts and 3/16"

washers. *See Figure "B"*. Attach the black wire from the compressor to a suitable ground source on the vehicle.

STEP 2 – MOUNT THE MANIFOLD BLOCK

Select the valve blocks from your kit. Install the pressure sensors into the back of the valve blocks. *See Figure "A"*. Select a convenient location to mount the valve blocks near the compressor. Mark the four mounting holes using the valve block as a template and a center punch, then drill four 9/32" holes. Mount the valve block using the supplied 1/4-20 x 2-1/2" bolts and 1/4-20 washers and nuts.

STEP 3 – MOUNT THE ECU

Select a location away from direct road spray and close to the compressor and valve blocks. Mark the two mounting holes using the ECU as a template with a center punch. Drill two 3/16" holes and mount ECU using two 10-32 x 3/4" machine screws and 10-32 nylock nuts.

STEP 4 – WIRE THE ECU, COMPRESSOR, AND VALVE BLOCK

Attach the tan wire and one white wire with ring terminal to the studs of the pressure sender at **PS1**. Attach the violet wire and another white wire to the studs of the pressure sender at **PS2**. Plug the connector with the tan/white and violet/white wires into the valve block. Attach the orange wire and one white wire with ring terminal to the studs of the pressure sender at **PS1** on the second valve block. Attach the blue wire and the last white wire to the studs of the pressure sender at **PS2** on the second valve block. Plug the connector with the orange/white and blue/white wires into the valve block. Ground the compressor (black wire with ring terminal), ECU (black wire with ring terminal), and valve blocks (black wires with ring terminal) to a suitable location on the chassis. Attach the red wire with the spade terminal to the red wire of the compressor. Route the red wire with the fuse to a +12VDC power source. Attach the yellow wire to an ignition-activated source. *See Figure "A"*.

STEP 5 – MOUNT THE WIRELESS GAUGE

The wireless gauge can be mounted in the cabin using the four Velcro pads. Place the pads on the back of the gauge and then firmly place the gauge onto the mounting location. The gauge should not be left outside of the vehicle if not in operation.

STEP 6 – ROUTE THE AIR LINE

Cut a section of airline tubing that will reach from the compressor to the valve blocks. Cut the airline tubing as squarely as possible, insert the tubing into the male fitting on the compressor, and then into the supplied tee fitting. Route a section from the tee fitting to the fittings on both valve blocks labeled **IN**. Cut a section of airline tubing that will reach from the valve block to one of the air springs. Cut the airline tubing as squarely as possible, insert the tubing into the fitting on the valve block labeled **LF/LR**, and then insert the other end into the left front/left rear air spring. Use the nylon ties provided to secure the airline tubing to the vehicle. Route the tubing to avoid direct heat from the exhaust system and away from any sharp edges. Repeat this last step on the other right front/right rear air spring and connect to the valve block port labeled **RF/RR**. There is a fitting on the valve block labeled **EXH** for exhaust. This is an option and not necessary for proper operation.

STEP 7 – USING THE WIRELESS CONTROLLER

With the Wireless Air Command kit and the air springs installed, you are ready to test the system. Re-attach the negative battery cable and place the 9V battery into the gauge. Turn on the vehicle's ignition. The gauge will display how much air pressure is in the system.

Once the system has been turned on (press any of the buttons), the **MODE** and **ARROW** keys are used to cycle through the screen and make selections to inflate/deflate the air springs. Pressing the **MODE** button once will display an arrow pointing at the Front Left (FL) corner. Pressing the up/down button at this time will change the pressure in the air spring. Continuing to press the **MODE** button will cycle through the corners:

Press MODE	Selection
1	Front Left (LF)
2	Front Right (RF)
3	Rear Left (LR)
4	Rear Right (RR)
5	Fronts (LF & RF)
6	Rears (LR & RR)
7	All corners (LF,RF,LR,RR)
8	Returns to single selection (LF)

Once the pressure has been selected, the system will turn on the compressor or open the exhaust valve to change the pressure. The change can be stopped by pressing either arrow key.

The display will turn off after 20 seconds of inactivity. To show the display, just press any of the buttons.

STEP 8 – CHECK THE SYSTEM

Inflate the air springs to 70 psi or the max air spring pressure, which ever is less, and check the fittings for air leaks with a solution of soap and water. If a leak is detected at a tubing connection, check to make sure that the tube is cut as squarely as possible and that it is pushed completely into the fitting. The tubing can easily be removed from the fitting by first releasing the pressure from the air spring, then by pushing the collar towards the body of the fitting and holding, then pulling the tube out.



www.riderite.com



2489/2500 NOTICE

TROUBLESHOOT WIRELESS INSTALLATION

- The display shows 120 PSI; After the bags are inflated, the system exhaust to 0 PSI; The system will not inflate.
 - The white wires (daisy-chain) are grounded.

- The display reads 0 PSI; The system does not respond to any inputs; Cycles back to 0 PSI.
 - Valve block is not grounded.

- Display shows correct pressure; Will not open valves to inflate; Will not turn compressor on; Will exhaust to correct pressure.
 - ECU is not grounded.

- System will not stop at correct pressure; Compressor continuously inflates one side while the other side stays at 0 PSI. IF PRESSURE SENDER WIRE PAIRS ARE REVERSED
 - Pressure sender wires are reversed (attached to the wrong

- If the display read 0 PSI; Tries to inflate one corner but exhausts to 0 PSI; Other corner works correctly.
 - Pressure sensor has failed. If possible, this can be verified with an OHM reading. The normal reading at 0 PSI should be ~10 OHMS.



Do Not Return This Product to the Dealer or Distributor

If you are

- missing parts,
- experiencing installation problems, or
- have technical concerns regarding this product,

you may contact a Firestone Technical Service Representative at rrtech@fsip.com or at 800-888-0650 (option 1, and then option 2). Representatives are available from 7:30 a.m. – 4:30 p.m. Eastern on Monday – Friday, excluding holidays. If you are located outside of the United States, you should first contact your distributor or dealer directly with any issues.

When contacting Technical Service, please have the kit or part # ready, along with the make, model, and year of the vehicle. You may also need to provide details, such as 2WD/4WD or if the vehicle has been lifted or lowered from stock height.

If you have a warranty concern, please include in your email a detailed description of the situation, a photo(s) of the issue, and your contact information, including ship-to address.

WARRANTY COVERAGE*— The Ride-Rite™ kits, components, and accessories are warranted against defects in workmanship and materials. This warranty does not cover service or labor charges, neglect...to the product.

PERIOD OF COVERAGE:

- | | |
|---|--|
| • Ride-Rite air springs – Lifetime Limited | • Work-Rite load assists – 2 Years Limited |
| • Sport-Rite air springs – Lifetime Limited | • Air-Rite accessories – 2 Years Limited |
| • Coil-Rite air springs – Lifetime Limited | • Brackets, hardware, fittings, air line, and other components – 2 Years Limited |
| • Level-Rite air springs – Lifetime Limited | |

HOW TO MAKE A WARRANTY CLAIM — If you purchased your air springs in the U.S. or Canada and believe you have a part with a warrantable defect, call Firestone directly at 1-800-888-0650.

International customers should contact their distributors or dealers directly with any problems.

(*) Please refer to the “Firestone Limited Lifetime Air Spring Warranty” for details, terms, and conditions.

WARRANTY QUESTIONS

Go to www.riderite.com/installation-support
Select “Warranty Info” tab