

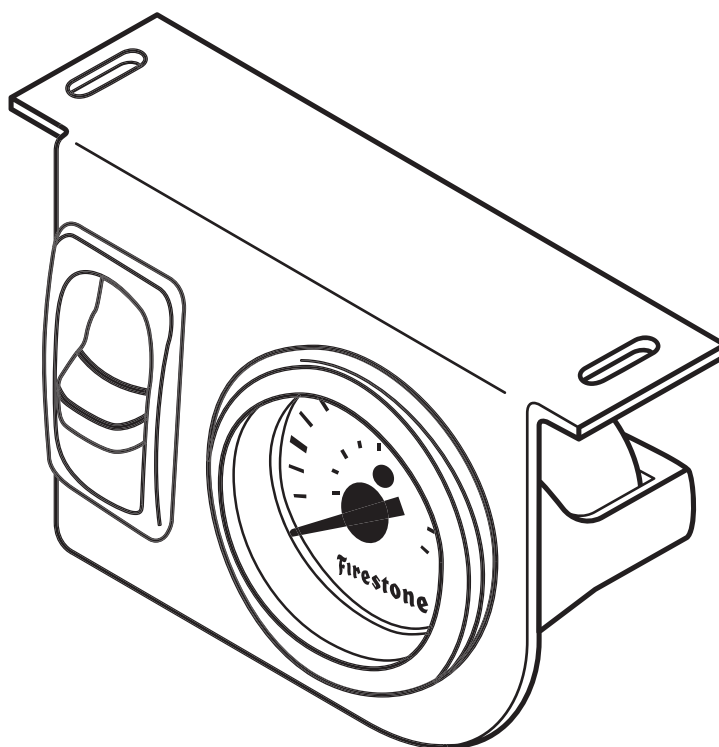

riderite.com

INSTALLATION INSTRUCTIONS



Firestone

Firestone Industrial Products

! IMPORTANT

PLEASE DON'T HURT YOURSELF, YOUR KIT OR YOUR VEHICLE. TAKE A MINUTE TO READ THIS IMPORTANT INFORMATION.

SAFE INSTALLATION

Please take all safety precautions during installation. A hydraulic jack can fail, and if that happens, you can be seriously hurt, or worse, if you are relying on it to hold up the vehicle. If you use a hydraulic jack, secure jack stands in the appropriate locations and chock any tires still touching the ground.

Wear safety glasses or goggles. Your eyes may be lower than some parts and pieces, and you don't want to lose an eye.

Remove the possibility of any electrical issues by disconnecting the negative battery cable.

VEHICLE GVWR

NEVER exceed the maximum load recommended by the vehicle manufacturer (GVWR). The GVWR can be found in your vehicle's owner's manual or on the data plate on the driver's side door. Consult your local dealership for additional GVWR specifications.

INFLATING THE AIR SPRINGS

When inflating Air Springs, add air pressure in small quantities, checking air pressure frequently. The Air Springs have much less air volume than a tire, so they inflate much more quickly.

PRESSURE TO LOAD

Be sure to review the load limits noted in the Air Spring Kit Installation Instructions (sold separately).

APPROPRIATE AIR PRESSURE

For best ride, use only enough air pressure in the Air Springs to level the vehicle when viewed from the side (front to rear). This will vary, depending on the load, location of the load, condition of the existing suspension, and personal preference.

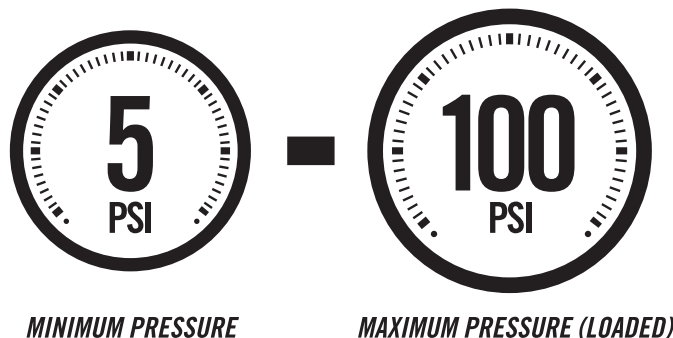

ONCE INSTALLED SUCCESSFULLY, FOLLOW THESE PRESSURE REQUIREMENTS FOR THE AIR SPRINGS:







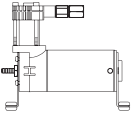
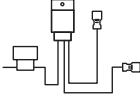

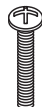

PARTS

Compare the parts below to your kit. Assure you have all pieces, and organize them for an easier installation.

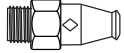
MAIN KIT CONTENTS

PART # 2572	 x1 SINGLE AIR CONTROL PANEL	PART # 9523	 x1 AIR COMPRESSOR	PART # 9307	 x1 RELAY HARNESS
PART # 9008	 x1 AIR LINE TUBE (30 FEET)				

A21-760-2538 HARDWARE PACK

PART # 3087	 x7 10-32 x 1" MACHINE SCREW	PART # 9078	 x1 SMALL RING TERMINAL	PART # 3055	 x1 1/8 NPT PUSH-TO-CONNECT STRAIGHT FITTING
PART # 3008	 x7 10-32 LOCK NUT	PART # 9083	 x2 WIRE CONNECTOR	PART # 9041	 x1 LARGE RING TERMINAL
PART # 3086	 x14 #10 FLAT WASHER	PART # 3025	 x1 PUSH-TO-CONNECT T-FITTING	PART # 9036	 x15 NYLON TIE

CONTENTS AND OVERVIEW

PAGE 4	PLANNING THE INSTALL
PAGE 5	PREPARE AIR COMPRESSOR & CONTROL PANEL
PAGE 6	DRILL HOLES FOR AIR COMPRESSOR INSTALLATION
PAGE 7	INSTALL THE AIR COMPRESSOR
PAGE 8	AIR COMPRESSOR TO CONTROL PANEL AIR LINE TUBE
PAGE 9	AIR SPRINGS TO CONTROL PANEL AIR LINE TUBE
PAGE 10	INSTALL RELAY HARNESS
PAGE 11	FINISH CONTROL PANEL WIRING & INSTALLATION
PAGE 12	INSTALL THE AIR FILTER & CLEAN UP INSTALLATION
PAGE 13	TEST THE SYSTEM
PAGE 14	FIXING AN AIR LEAK

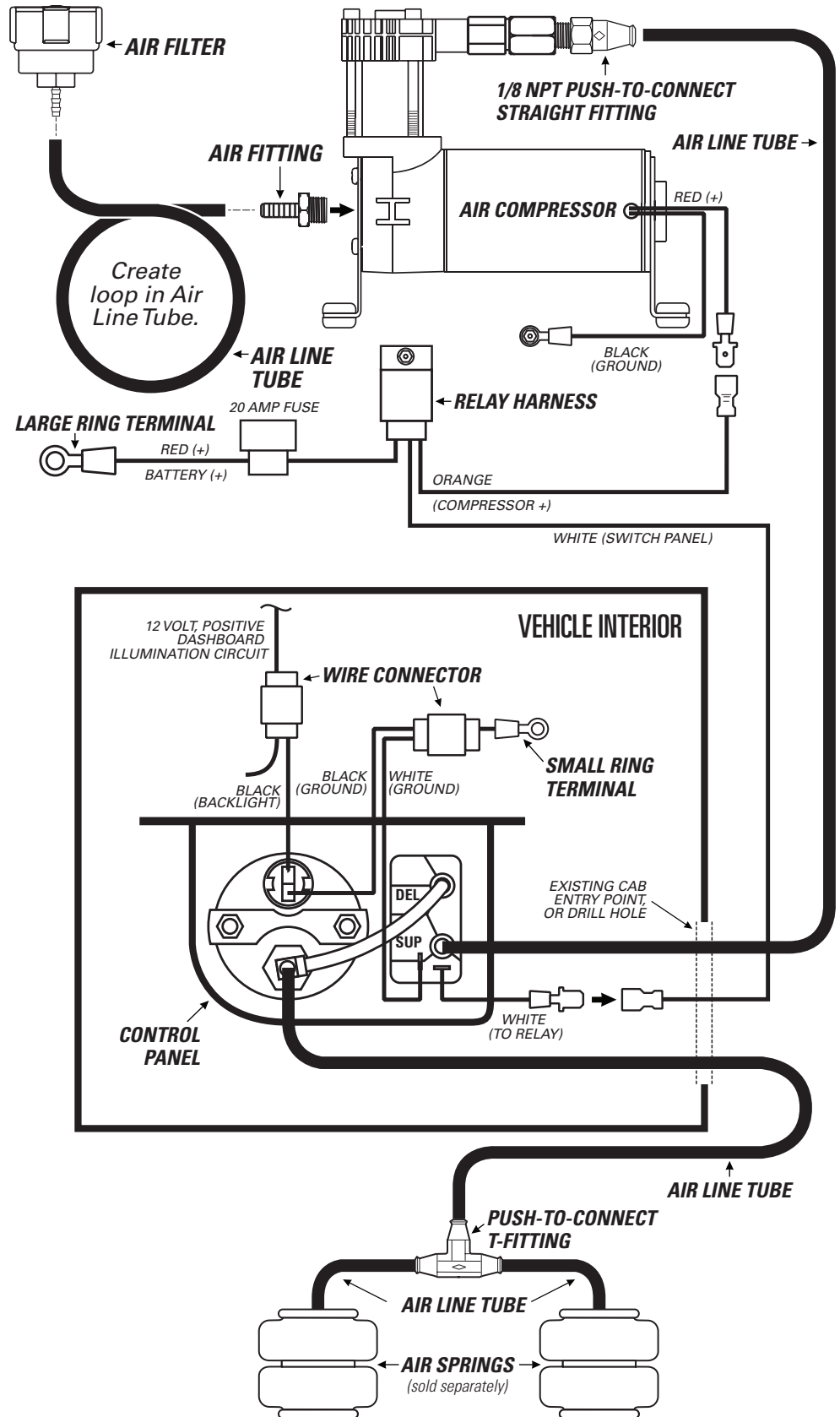

PLANNING THE INSTALL

THESE PLANNING STEPS WILL HELP YOU SAVE TIME AND WILL MAKE THE INSTALLATION EASIER.

DETERMINE THE MOUNTING LOCATION FOR THE CONTROL PANEL

- Mount inside the vehicle cab, in a place where you will not hit or kick it.
- Allow room for the Air Line Tube to run without sharp curves or bends.
- Do not obstruct your view or ability to safely operate the vehicle.

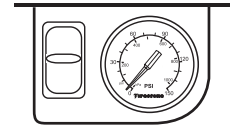

DETERMINE THE MOUNTING LOCATION FOR THE AIR COMPRESSOR

- Provide ample air flow.
- Protect from airborne debris and moisture.
- If using the optional Frame Installation Kit (Part # 2497), consider the guidelines above, and follow Kit's instructions.

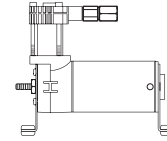

PLAN INSTALLATION ROUTES FOR WIRING AND AIR LINES INTO CAB

- If possible, use existing factory grommet, such as where a wiring harness enters the cab.
- If not possible, drill a hole large enough for two Air Line Tubes and a ground wire. Make sure the wiring and Air Line Tubes are not exposed to sharp metal edges that can damage them.

SOAK AIR LINE TUBE ENDS IN HOT WATER BEFORE INSTALLING ONTO BARBED FITTINGS

- The hot water makes the air line tube easier to work with and enables it to shrink onto the barbed fitting for a better seal.



TAPE ALL ELECTRICAL CONNECTIONS

- Use electrical tape to appropriately secure and protect all electrical connections.

USING PUSH-TO-CONNECT FITTINGS FOR AIR LINES

Your kit includes push-to-connect fittings to connect the Air Line Tubes to hardware. Use the instructions below when using the air line.

- 1** Insert end of Air Line Tube into Air Fitting.

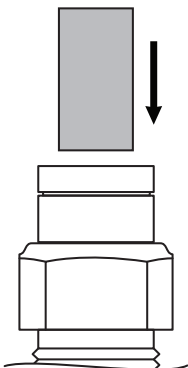

- 2** Push Air Line Tube into Air Fitting as far as possible.

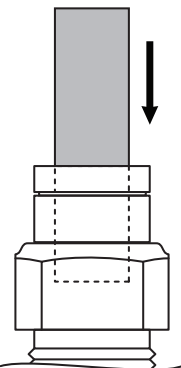

- 3** Gently pull on the Air Line Tube to check for a secure fit.

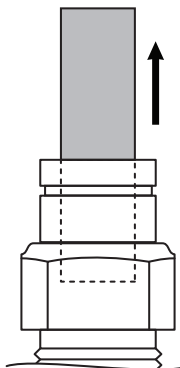

- 4** To remove, push down collar and gently pull Air Line Tube away.

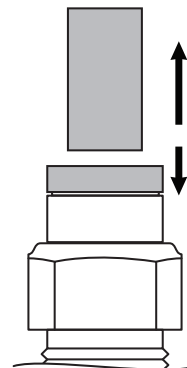

Removal Tip: Use a 1/4", 5/16", or 6mm open-ended wrench to push the collar down.

1

PREPARE THE AIR COMPRESSOR

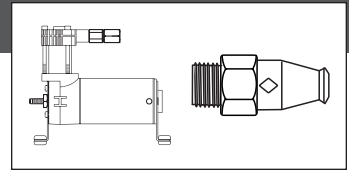

- 1 Install 1/8 NPT Push-to-Connect Straight Fitting on the Check Valve.

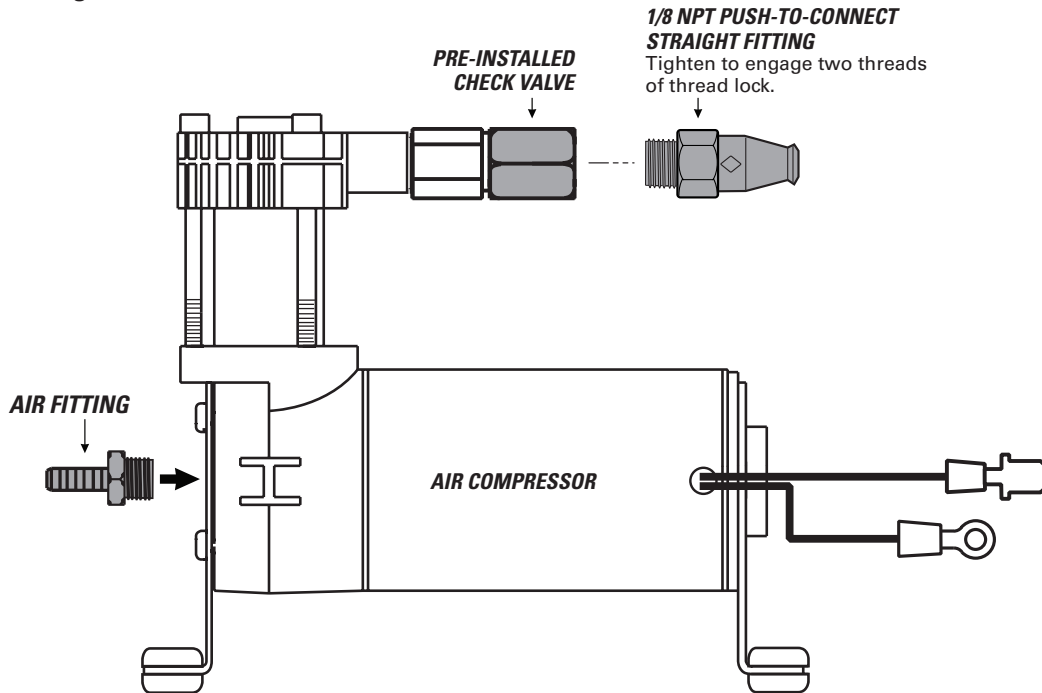

1/8 NPT PUSH-TO-CONNECT STRAIGHT FITTING
Tighten to engage two threads of thread lock.

2

DRILL HOLES FOR CONTROL PANEL INSTALLATION

Use the location you selected during the Planning the Installation step on Page 4.

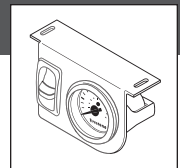

- 1 Using the Control Panel slots as a template, mark two drill locations with a punch or marking tool.
- 2 Drill a 3/16" diameter hole on each center mark.
- 3 Do not mount the Control Panel until Step 8.

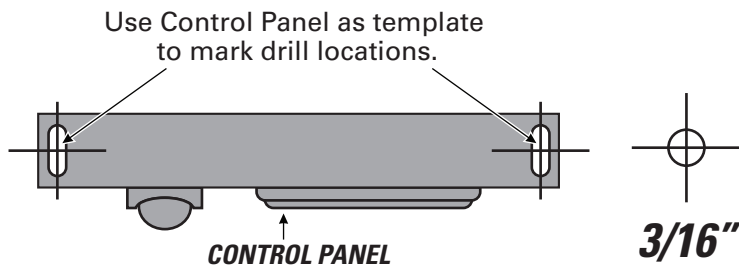

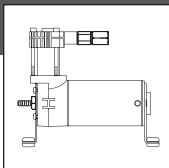

IF YOU ARE USING THE OPTIONAL FIRESTONE AIR COMPRESSOR MOUNTING KIT (PART # 2497), SKIP THIS STEP AND REFER TO THE MOUNTING KIT'S INSTRUCTIONS.



CHECK SURROUNDING AREA AND BACK SIDE OF MOUNTING LOCATION TO AVOID DRILLING INTO EXISTING LINES OR WIRING.

1 Using the Air Compressor as a template, mark four drill locations with a punch or marking tool.

2 Mark ground wire fastening location within reach of the ground wire Ring Terminal.

3 Drill 3/16" diameter holes. Remove any burrs and debris from drill holes.

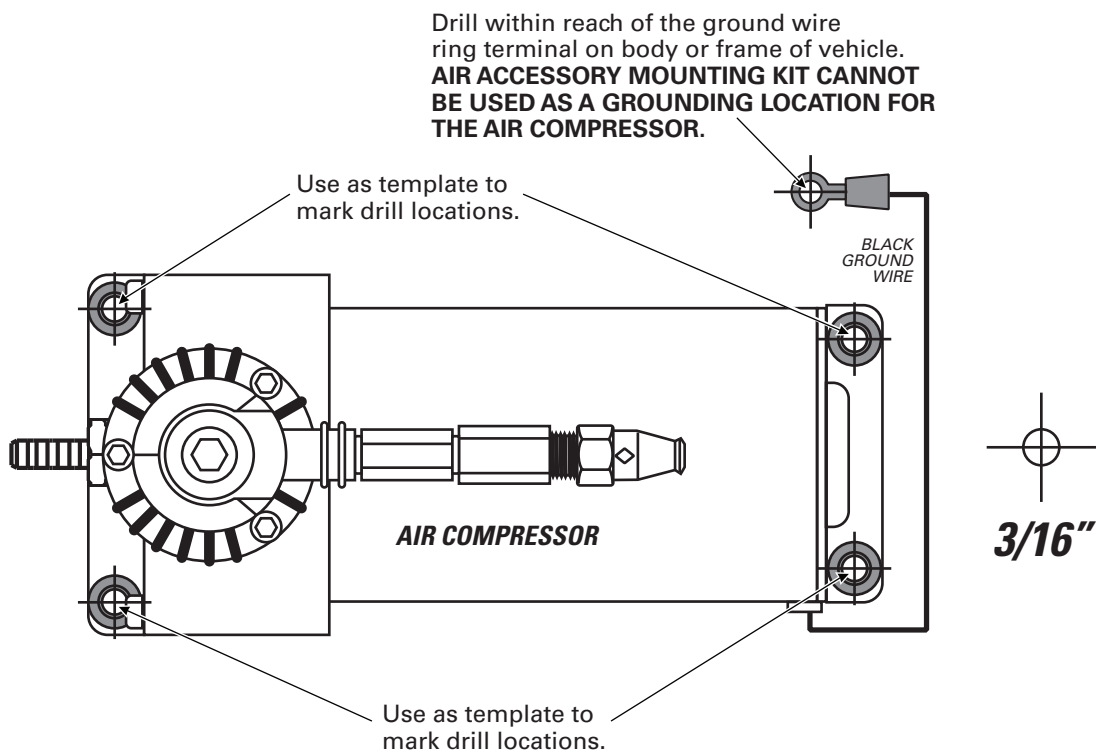

4

INSTALL AIR COMPRESSOR

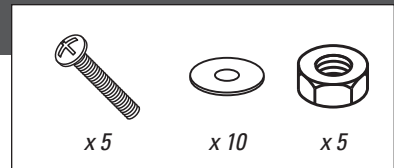

DO NOT OVER TIGHTEN MOUNTING BOLTS AND NUTS. TOO MUCH TORQUE CAN CRUSH THE BRASS INSERTS AND RUBBER ISOLATORS.

1 Mount the Air Compressor to the drill hole location using the supplied fasteners. DO NOT OVERTIGHTEN.

2 Mount the black ground wire Ring Terminal using the supplied fasteners. Assure that the Ring Terminal makes a solid contact with bare metal for a proper ground. (Optionally, you can run the negative to the negative battery terminal.)

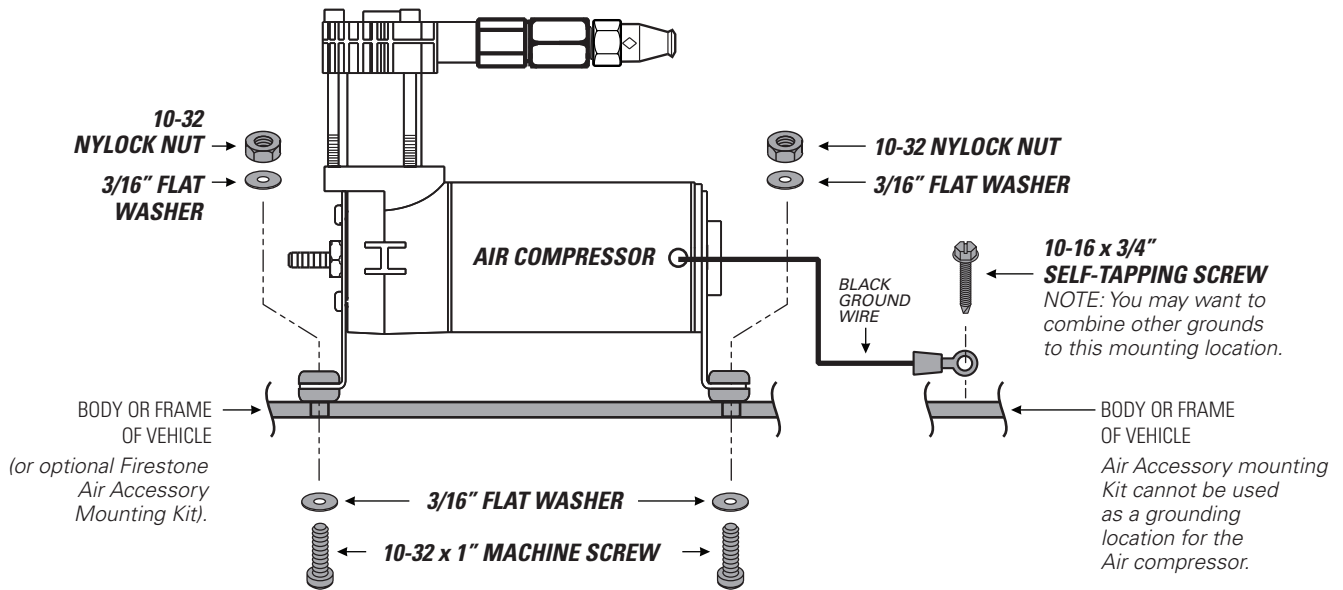

TO CREATE A PROPER GROUND, ASSURE THE GROUND RING TERMINAL CONTACTS BARE METAL AND IS FASTENED SECURELY. AFTER INSTALLATION, YOU MAY OPTIONALLY COAT THE RING TERMINAL IN SILICONE TO PROTECT IT FROM CORRODING.



Use the route you selected during the Planning the Installation step on Page 4.

1 Route the Air Line Tube from the Air Compressor to the Control Panel, leaving room to secure line safely. Use guidelines below to cut.



EXHAUST ALL AIR FROM THE SYSTEM PRIOR TO RELEASING AIR TUBES FROM AIR FITTINGS.



2 Install the Air Line Tube end onto the barbed fitting on the back of the Control Panel switch as shown.



FOR PROPER INSTALLATION, SOAK AIR LINE TUBE ENDS IN HOT WATER BEFORE INSTALLING ONTO BARBED FITTINGS.

3 Install the Air Line Tube end into the 1/8 NPT Push-to-Connect Straight Fitting on the top of the Air Compressor.

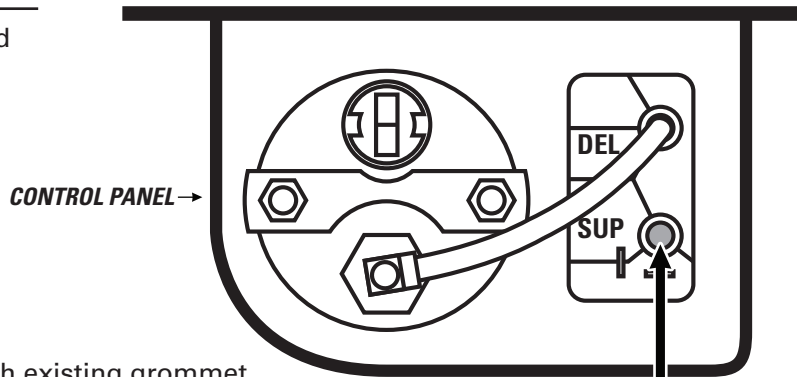

Pass through existing grommet or drilled hole to enter cab.

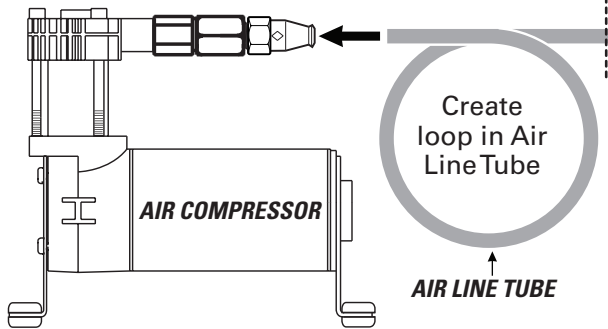

THE AIR LOOP CREATES A TRAP FOR CONDENSATION TO GATHER. WITHOUT THIS TRAP, THE AIR COMPRESSOR COULD BE DAMAGED BY WATER INTAKE.

DO

Make sure the cut is as square as possible. Use a tube cutter or sharp utility knife.

DON'T

Fold or kink the Air Line Tube. Cut the Air Line Tube at an angle. Use pliers, scissors, snips, saws, or side cutters.

PROPER AND IMPROPER CUTS IN THE AIR LINE TUBE

<p>Square cut AIR LINE TUBE 90°</p>	<p>AIR LINE TUBE</p>	<p>AIR LINE TUBE</p>	<p>AIR LINE TUBE</p>
---	----------------------	----------------------	----------------------

6

INSTALL T-FITTING AND ROUTE AIR LINE TUBE TO CONTROL PANEL

Use the route you selected during the Planning the Installation step on Page 4.

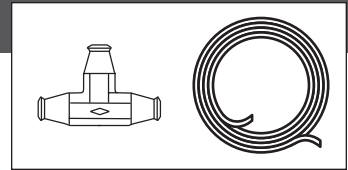

EXHAUST ALL AIR FROM THE SYSTEM PRIOR TO RELEASING AIR TUBES FROM AIR FITTINGS.



FOR PROPER INSTALLATION, SOAK AIR LINE TUBE ENDS IN HOT WATER BEFORE INSTALLING ONTO BARBED FITTINGS.

1 Route the Air Line Tube from the Control Panel to the Air Springs.

2 Install the Air Line Tube end onto the barbed fitting on the back of the Control Panel pressure gauge as shown.

3 Determine a safe location for the Push-to-Connect T-fitting, where Air Line Tubes from the Air Springs and the Control Panel can safely meet.

4 Install the Air Line Tubes from the Air Springs into opposite ends on the Push-to-Connect T-fitting, as shown.

5 Install the Air Line Tube from the Control Panel to the single end on the Push-to-Connect T-fitting.

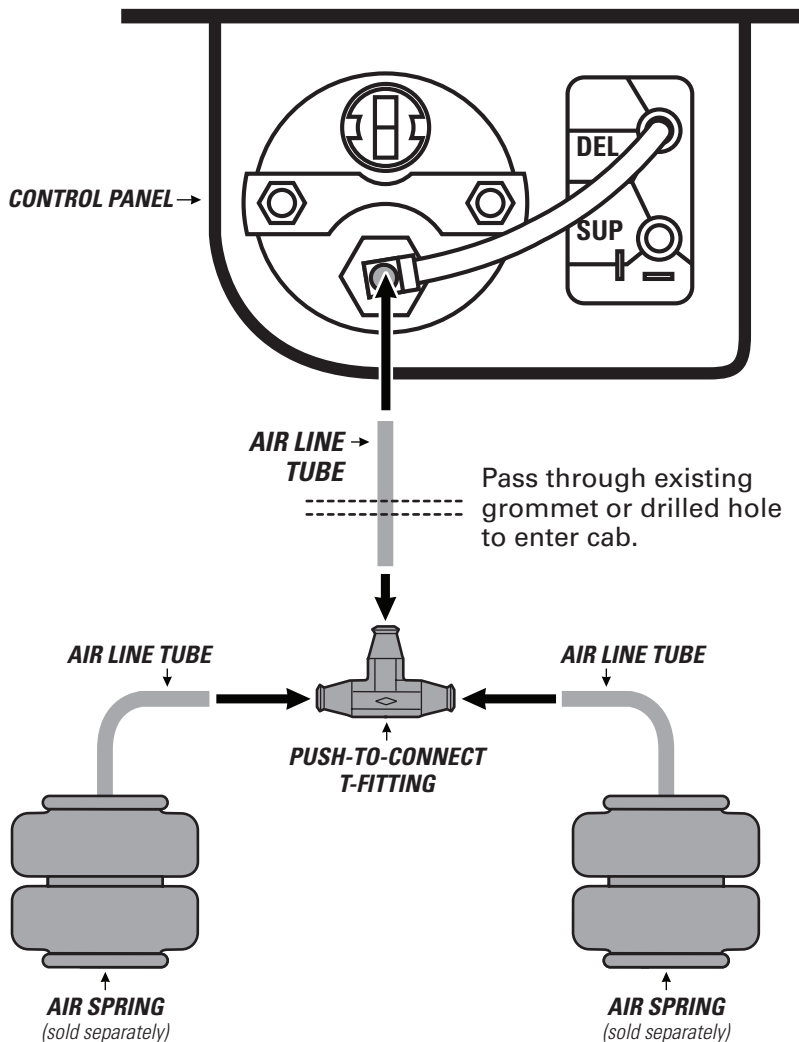

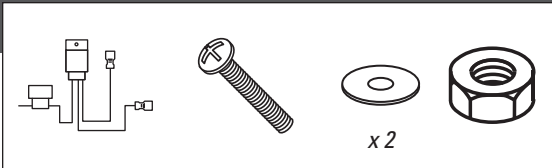

1 Select a safe location within 3 feet of the Air Compressor.

2 Mark and drill a 3/16" hole to mount the relay housing on the Relay Harness. Secure with fasteners shown.

3 Route the white wire with the female spade connector labeled "switch panel" to the Control Panel.

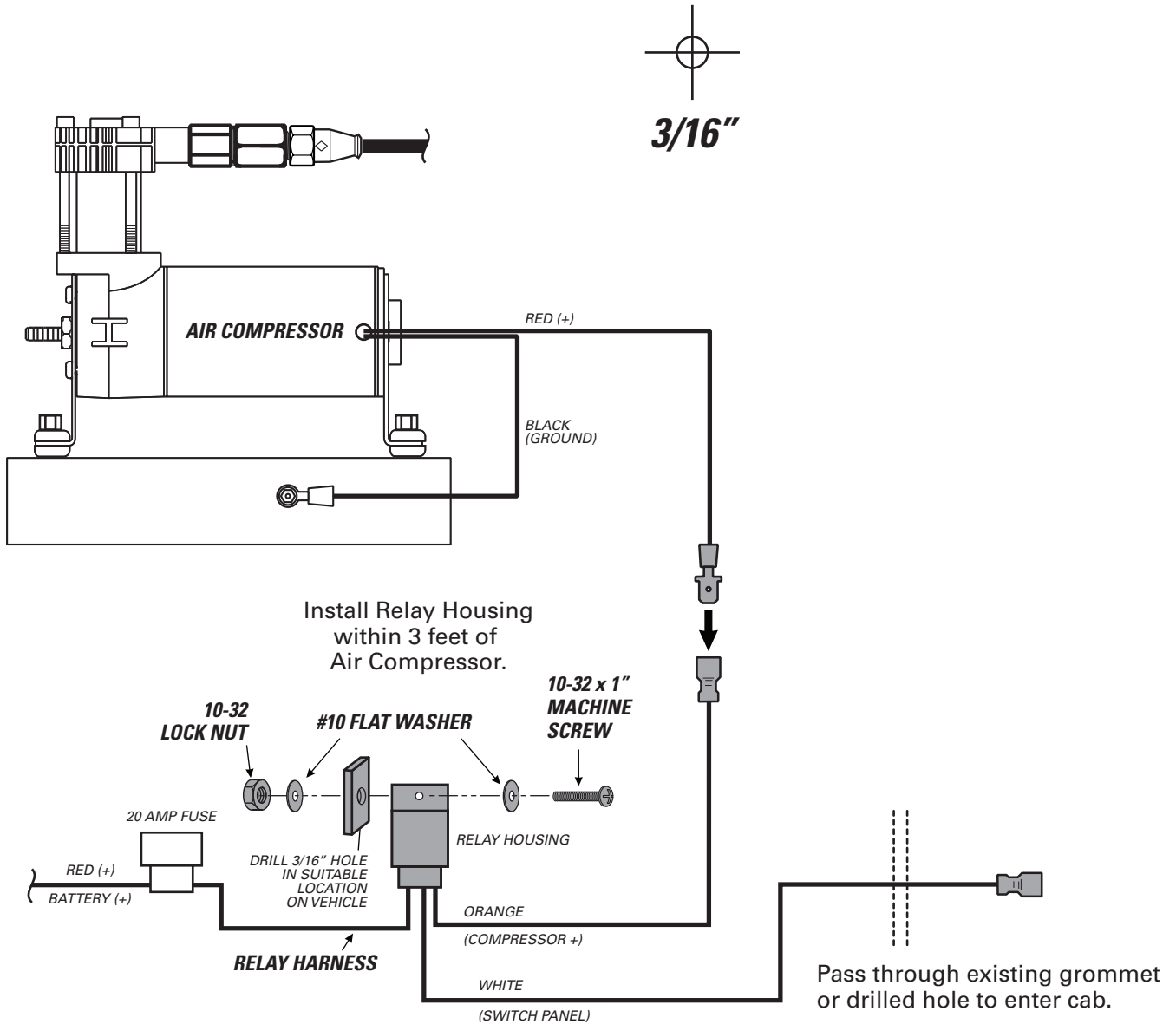

8

FINISH WIRING AND INSTALLATION



x 2



x 3



x 6



x 3

1 Connect wires, install Ring Terminals and Wire Connectors as shown below.

2 Fasten Control Panel ground wires to vehicle as shown.

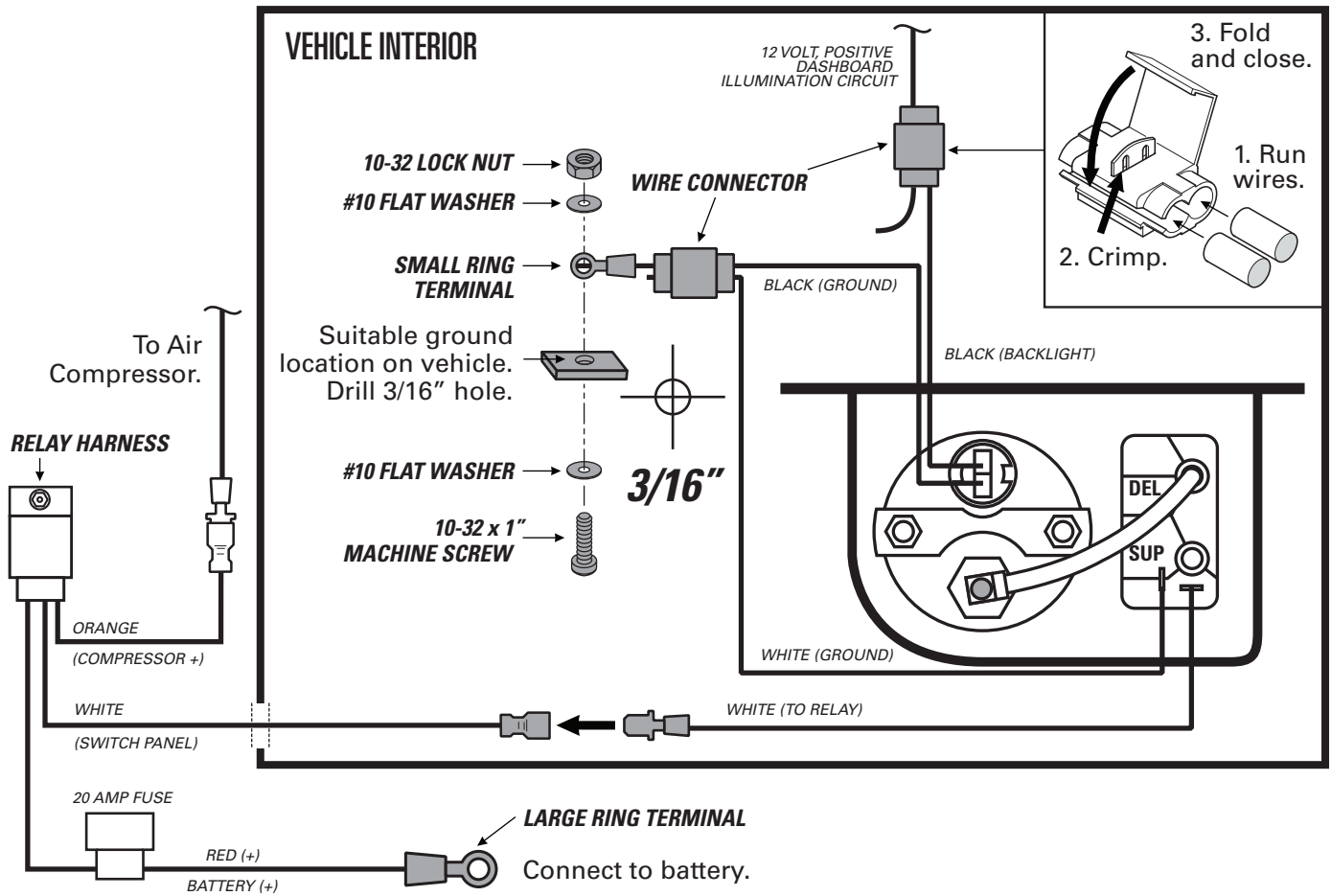

3 Install the Control Panel using the supplied fasteners.

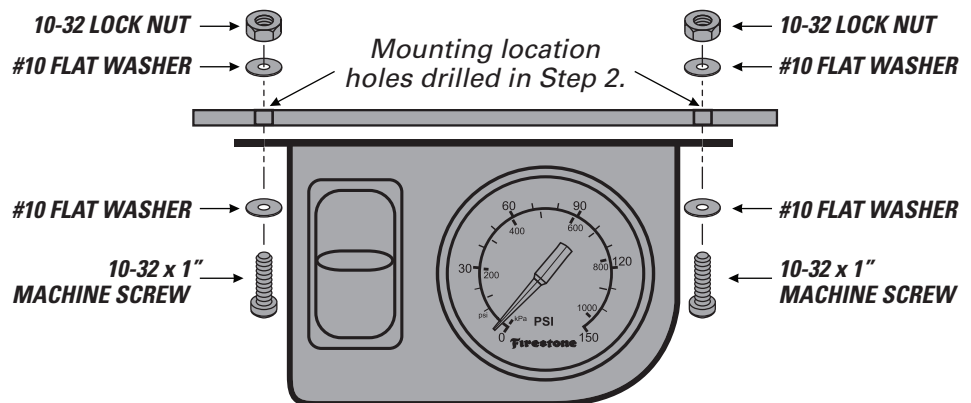

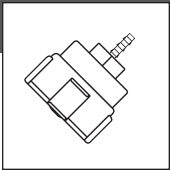

FILTER LIFE WILL VARY BASED ON ENVIRONMENTAL CONDITIONS. PROTECT THE AIR COMPRESSOR BY CHANGING THE AIR FILTER MORE FREQUENTLY IN DUSTY CONDITIONS.

1 Fully secure the Air Filter barb into the Air Line Tube from the Air Compressor Kit.

2 Press Air Line Tube onto the barb on the Air Compressor Air Fitting until fully seated. Assure you create a loop in the Air Line Tube, as shown, when securing it to the vehicle.

3 Periodically check the Air Filter during operation. When the Air Filter is dirty and needs to be replaced, contact an Authorized Firestone dealer to purchase a new one.

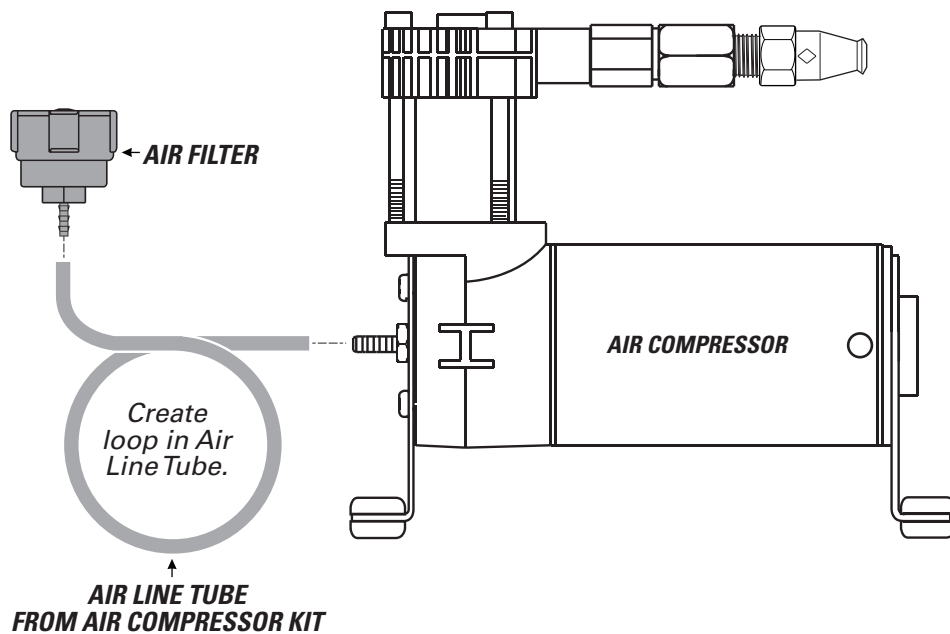

1 Clean up the installation using supplied Nylon Ties, and return all factory parts and materials to operative state.



USING SUPPLIED NYLON TIES, SECURE ALL WIRING AND AIR LINE TUBE IN A MANNER THAT DOES NOT OBSTRUCT YOUR VIEW OR ABILITY TO SAFELY OPERATE THE VEHICLE.

10

TEST THE SYSTEM

With the Air Command Kit and your Air Springs installed, you are ready to test the system.

- 1** Re-attach the negative battery cable.

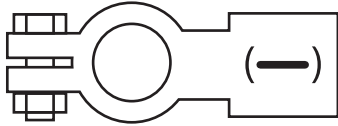

- 2** Turn on your vehicle's ignition.

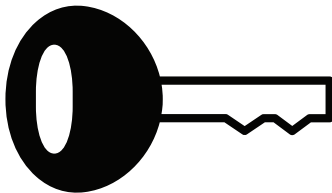

- 3** Push paddle switch up to inflate the Air Springs to 70 PSI.

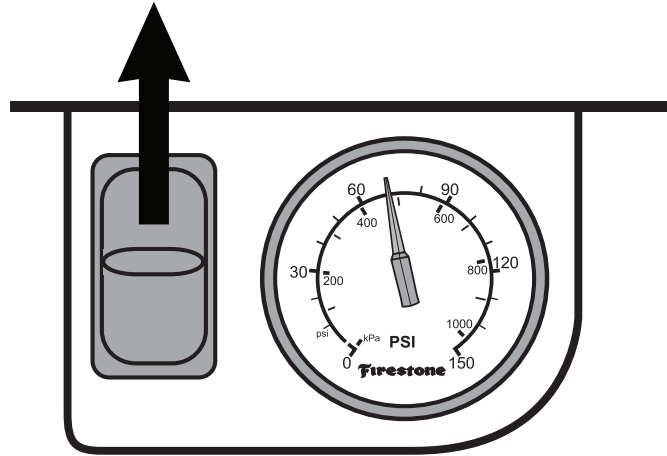

- 4** Spray fittings with soap and water mixture.



- 5** Observe bubbles.

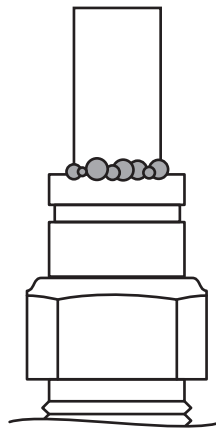

**SMALL SOAP BUBBLES
THAT DO NOT EXPAND**

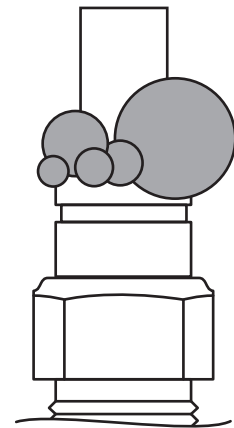

**SOAP BUBBLES
THAT EXPAND**



NO LEAKS?

Congratulations! You're riding right with the flip of a switch! Remember to review the Operating Instructions.

LEAK?

Bummer. Continue to Step 11 to fix the leak.



EXHAUST ALL AIR FROM THE SYSTEM PRIOR TO RELEASING AIR TUBES FROM AIR FITTINGS.



1 Push paddle switch down to release all air pressure from the Air Springs.

NOTE: While doing this, if you get a quick burst of air prior to the gauge dropping to 0 PSI, your lines are incorrectly swapped.

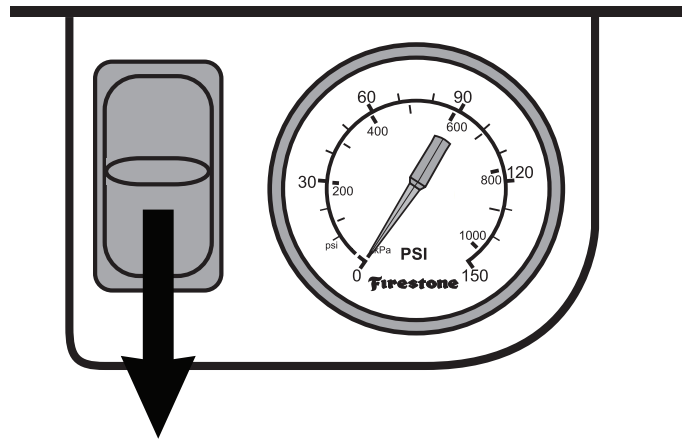

LEAK AT AIR LINE TUBE AND AIR FITTING

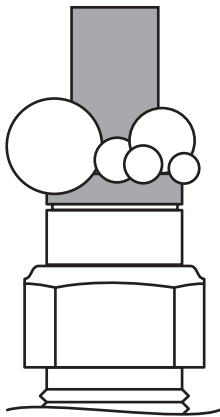

Release Air Line Tube (see page 4). Review proper cuts and procedures in Step 5. Repeat installation steps.

LEAK AT BASE OF AIR FITTING ON AIR SPRING

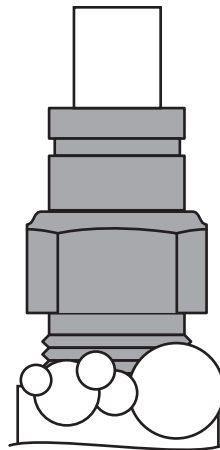

Tighten Air Fitting one turn or until leak stops.

LEAK AT A BARBED FITTING

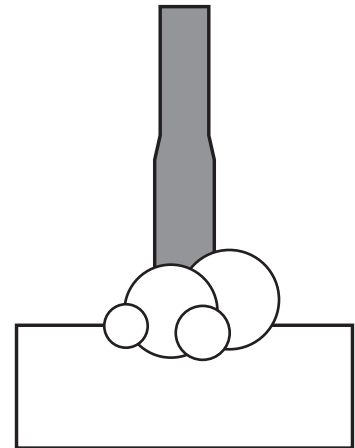

Being careful not to scar the metal barbs, cut away, check for debris. Trim Air Tube Line, **soak for 5 minutes in hot water**. Reinstall.

STILL HAVE A LEAK?

Refer to the Troubleshooting section of the Instruction Manual. If the leak persists, or if there is an issue with a leaking part, call 1-800-888-0650; Option 1; Option 1 for Tech Support.



riderite.com

BEFORE YOU DRIVE, CONFIRM THE FOLLOWING:

- Secure all Air Line Tubes and wiring inside the cab and on the outside of the truck.
- Make sure no wiring, Air Line Tubes, or hardware obstruct your vision or ability to safely operate the vehicle.
- The system passes the leak test and holds air.
- The Air Compressor ground Ring Terminal is contacting bare metal, and coated with silicone if possible.
- There is a loop in the Air Line Tubes as shown to prevent water or debris from getting into the Air Compressor head and damaging it.
- The air gauge backlight turns off when the ignition is off, or when dashboard lights do not illuminate.
- Put a minimum of 5 PSI in the Air Springs, unloaded.

NEED INSTALLATION HELP? 1-800-888-0650

Select Option 1 for Ride-Rite; Select Option 1 for Technical Support.

Or, email us at rrtech@fsip.com. If emailing, please include photos to help us better diagnose and understand any problems you may be experiencing.

Firestone

Firestone Industrial Products

CONNECT WITH US



@firestoneip



FirestoneIP



Firestone Ride-Rite



Do Not Return This Product to the Dealer or Distributor

If you are

- missing parts,
- experiencing installation problems, or
- have technical concerns regarding this product,

you may contact a Firestone Technical Service Representative at rrtech@fsip.com or at 800-888-0650 (option 1, and then option 2). Representatives are available from 7:30 a.m. – 4:30 p.m. Eastern on Monday – Friday, excluding holidays. If you are located outside of the United States, you should first contact your distributor or dealer directly with any issues.

When contacting Technical Service, please have the kit or part # ready, along with the make, model, and year of the vehicle. You may also need to provide details, such as 2WD/4WD or if the vehicle has been lifted or lowered from stock height.

If you have a warranty concern, please include in your email a detailed description of the situation, a photo(s) of the issue, and your contact information, including ship-to address.

WARRANTY COVERAGE*— The Ride-Rite™ kits, components, and accessories are warranted against defects in workmanship and materials. This warranty does not cover service or labor charges, neglect...to the product.

PERIOD OF COVERAGE:

- | | |
|---|--|
| • Ride-Rite air springs – Lifetime Limited | • Work-Rite load assists – 2 Years Limited |
| • Sport-Rite air springs – Lifetime Limited | • Air-Rite accessories – 2 Years Limited |
| • Coil-Rite air springs – Lifetime Limited | • Brackets, hardware, fittings, air line, and other components – 2 Years Limited |
| • Level-Rite air springs – Lifetime Limited | |

HOW TO MAKE A WARRANTY CLAIM — If you purchased your air springs in the U.S. or Canada and believe you have a part with a warrantable defect, call Firestone directly at 1-800-888-0650.

International customers should contact their distributors or dealers directly with any problems.

(*) Please refer to the “Firestone Limited Lifetime Air Spring Warranty” for details, terms, and conditions.

WARRANTY QUESTIONS

Go to www.riderite.com/installation-support
Select “Warranty Info” tab