



LEVEL-RITE

Congratulations - your new Air Helper Springs are quality products capable of improving the handling and comfort of your vehicle. As with all products, proper installation is the key to obtaining all of the benefits your kit is capable of delivering. **Please take a few minutes to read through the instructions to identify the components and learn where and how they are used.** It is a good idea to start by comparing the parts in your kit with the parts list below.

Be sure to take all applicable safety precautions during the installation of the kit. The instructions listed in this brochure and the illustrations all show the left, or driver's side of the vehicle. To install the right side assembly simply follow the same procedures.

Your kit includes separate inflation valves and air lines for each air helper spring. This will allow you to level your vehicle from side to side as well as from front to back. If you would rather have a single valve inflation system, your dealer can supply the required "T" fitting.

PARTS LIST

LEVEL-RITE SHOCK	7217	2	STRAIGHT FITTING	3055	2
HEAT SHIELD	0025	1	INFLATION VALVE	3032	2
HOSE CLAMP	5002	2	NYLON TIES	9036	6
5/16" FLAT WASHER	3033	4	THERMAL SLEEVES	0899	2
AIR LINE TUBING	0938	1			

IMPORTANT!

DO NOT COMPRESS SHOCK MORE THAN 1 INCH PRIOR TO & DURING INSTALLATION!

For your safety and to prevent possible damage to your vehicle, do not exceed the maximum load recommended by the vehicle manufacturer (GVWR). Although your Air Helper Springs are rated at a maximum inflation pressure of 100 psi, this pressure may allow you to carry too great a load on some vehicles. It is best to have your vehicle weighed once it is completely loaded and compare that weight to the maximum allowed. Check your vehicle owner's manual or data plate on driver's side door for maximum loads listed for your vehicle.

When inflating your Air Helper Springs, add air pressure in small quantities, checking pressure frequently during inflation. The air spring requires much less air volume than a tire and, therefore, inflates much quicker.

STEP 1 - PREPARE VEHICLE

Raise the rear of the vehicle and remove the wheels. Place jack stands rated for the weight of the vehicle under the frame, lower the vehicle onto the jack stands, and allow the rear suspension to extend.

Remove the nut and bolt from the bottom of the factory-style shock. Next, remove the bolt holding the top of the shock to the frame. These nuts and bolts will be reused. *See Figure "A"*.

STEP 2 - INSTALLING THE LEVEL-RITE

Install the male fitting into the air inlet on the side of the Level-Rite. Tighten the air fitting securely to engage the orange thread sealant. Insert the Level-Rite into the lower shock mount. Reinstall the factory hex bolt in the lower shock mount.

Position the Level-Rite over the upper shock mount and reinstall the hex bolt into the upper shock mount. Install the hex nut on the lower bolt and tighten both, the upper and lower hardware, to factory specifications.

STEP 3 - INSTALLING THE AIR LINE AND INFLATION VALVE

Uncoil the air line tubing and cut it into two equal lengths. **DO NOT FOLD OR KINK THE TUBING.** Try to make the cut as square as possible. Insert one end of the tubing into the straight fitting installed into the Level-Rite. Push the tubing into the fitting as far as possible, *see Figure "B"*. Select a location on the vehicle for the air inflation valves.

All illustrations are of the left, or drive's side.
 Follow the same procedures for installing
 the right, or passenger's side.

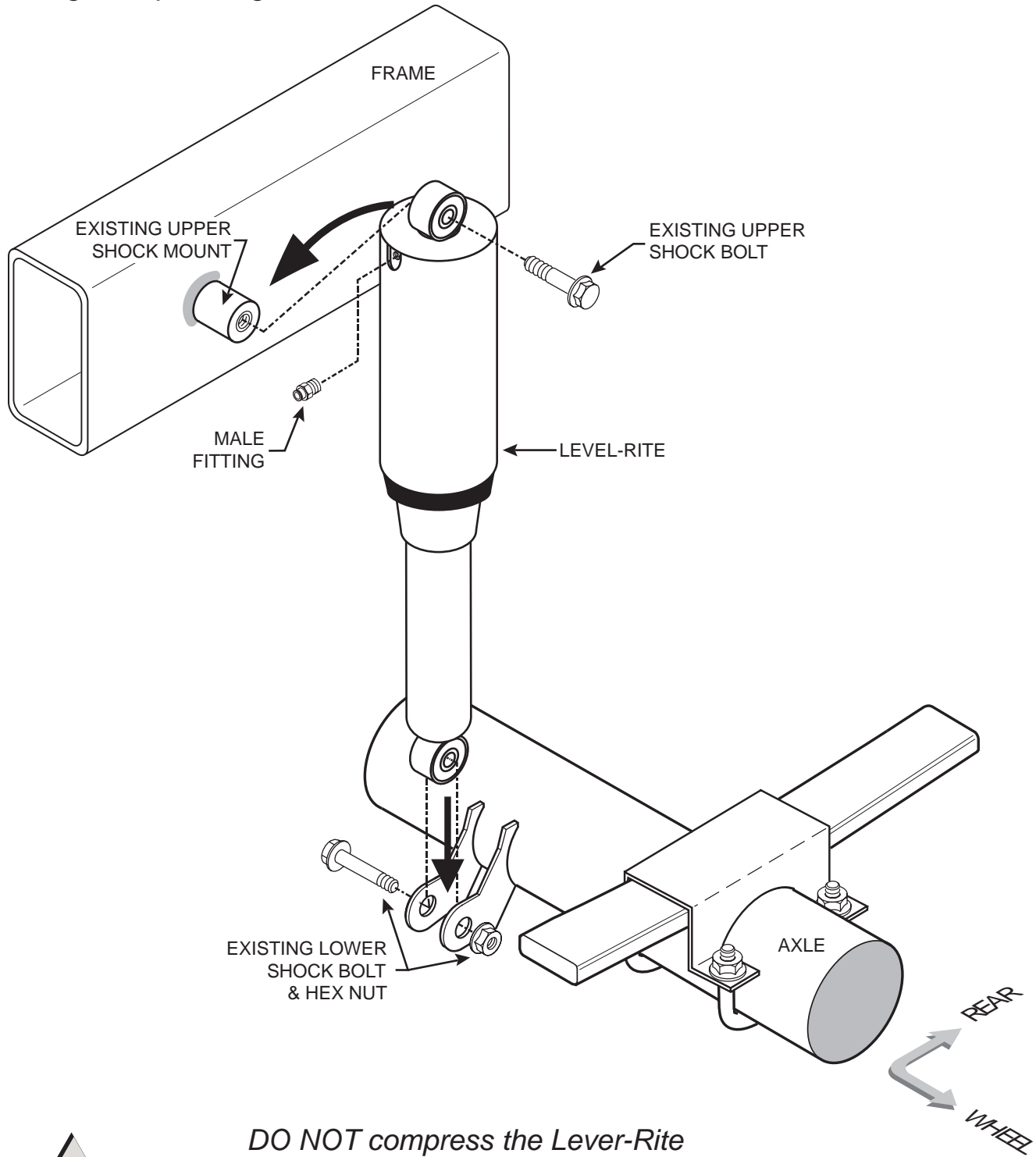

DO NOT compress the Lever-Rite
 more than 1" prior to or during installation!

**MINIMUM PRESSURE MUST BE MAINTAINED
 AT ALL TIMES!**

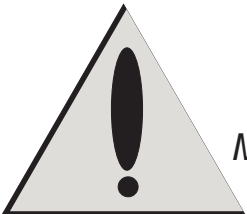

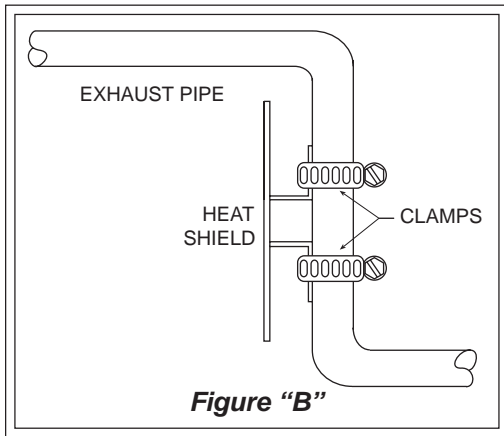

The location can be on the bumper or the body of the vehicle, as long as it is in a protected location so the valve will not be damaged, but maintain accessibility for the air chuck, *see Figure "E"*. Drill a 5/16" hole and install the air inflation valve using two 5/16" flat washers per valve as supports, *see Figure "D"*. Run the tubing from the air helper spring to the inflation valve, routing it to avoid direct heat from the engine, exhaust pipe, and away from sharp edges. Thermal sleeves have been provided for these conditions. If a thermal sleeve is required simply slide the sleeve over the air line tubing to the location requiring protection. The air line tubing should not be bent or curved sharply as it may buckle. Secure the tubing in place with the nylon ties provided. Push the end of the air line tubing into the inflation valve as illustrated, *see Figure "E"*.

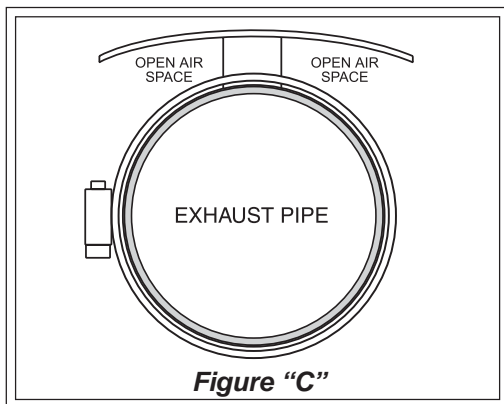

STEP 4 - HEAT SHIELD INSTALLATION

Bend the heat shield middle tab out at a 90 degree angle and bend the heat shield again half the distance up the tab at a 90 degree angle to form a "L" shape refer to *Figure "B"*. Mount the heat shield between the air spring and the exhaust pipe. Mount the heat shield using the clamps provided see *Figure "C"*. **Maintain clearance between heat shield and moving axle, lines, etc.** Bend the heat shield around the exhaust pipe, while allowing for a space of 1/2" to 1" as shown in *Figure "C"*.

STEP 5 - CHECK THE SYSTEM

Once the inflation valves are installed inflate the Air Over shocks to 70 psi and check the fittings for air leaks with an applied solution of soap and water. If a leak is detected at a tubing connection then check to make sure that the tube is cut as square as possible and that it is pushed completely into the fitting. The tubing can easily be removed from the fittings by pushing the collar towards the body of the fitting and then pulling out the tube. If a leak is detected where the brass fitting screws into the shock, remove the tubing by pushing the collar towards the body of the fitting and then pulling out the tube, then screw the brass fitting into the shock one additional turn. Reinstall the tubing and re-inflate the air springs and check for leaks as noted above.

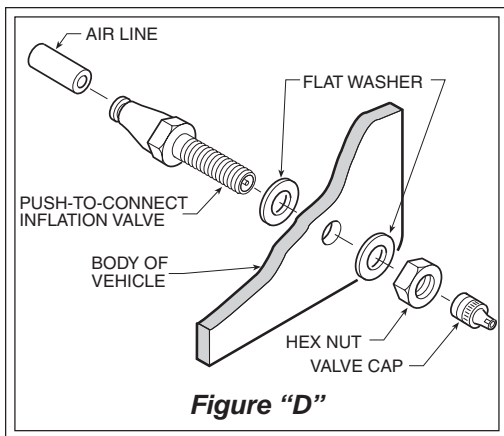

This now completes the installation. Install the wheels and torque the lug nuts to the manufactures specifications. Raise the rear of the vehicle, remove the jack stands, and lower the vehicle back onto the ground. **FOR BEST RIDE** use only enough air pressure in the air helper springs to level the vehicle when viewed from the side (front to rear). This amount will vary depending on the load, location of load, condition of existing suspension and personal preference.

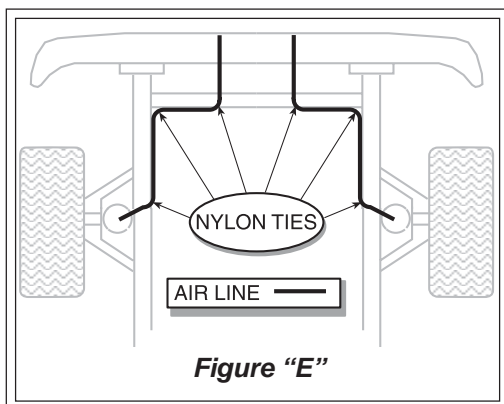

NOTE:	
MIN PRESSURE	10 PSI
MAX PRESSURE (LOADED)	100 PSI