

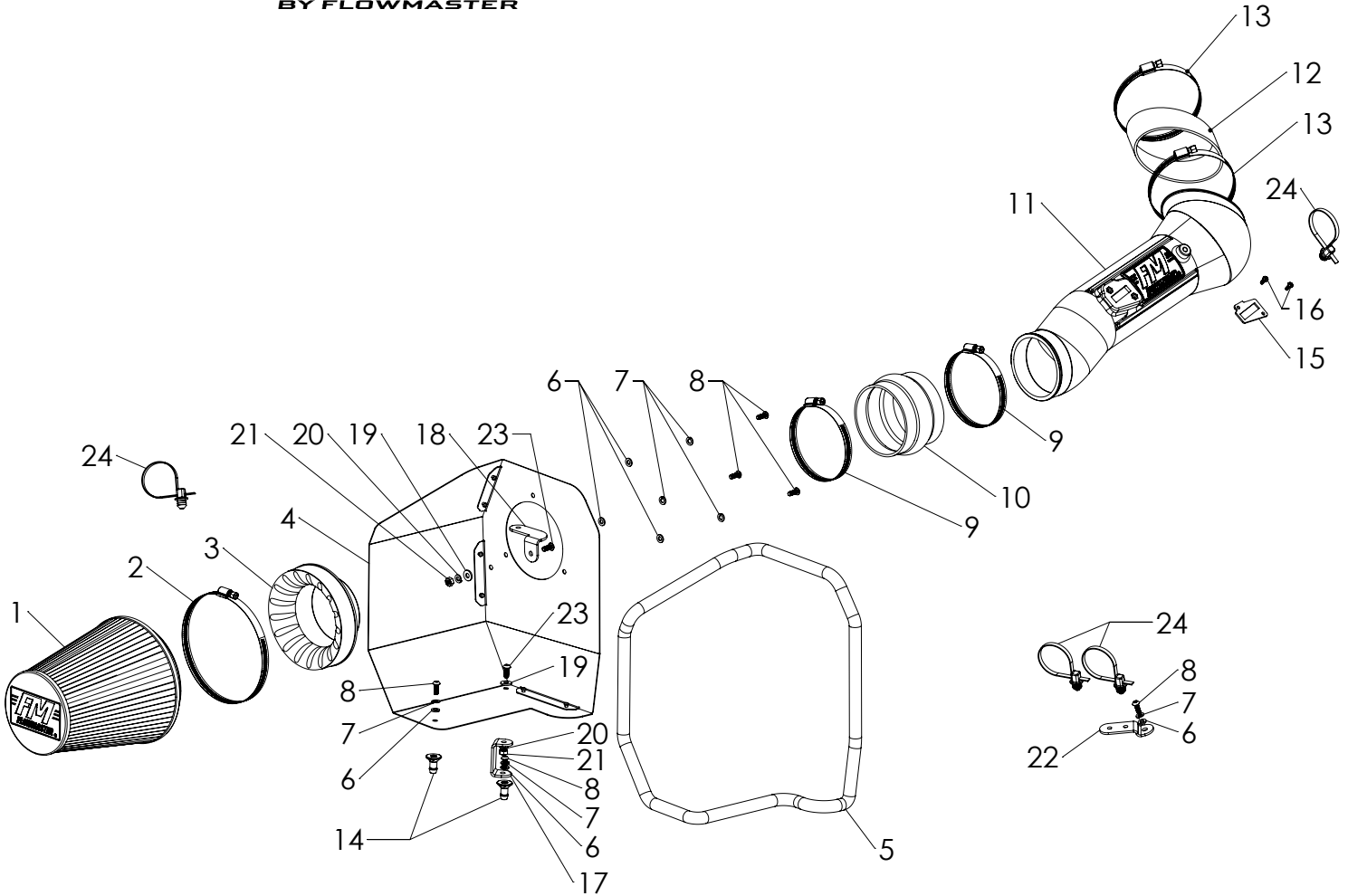

Installation Instructions for: SYSTEM # 615148

2011-2016 FORD F250 & F350 TRUCKS with 6.7L Turbo Diesel Engines

NOT LEGAL FOR SALE OR USE ON ANY POLLUTION-CONTROLLED MOTOR VEHICLE IN CALIFORNIA OR IN STATES THAT HAVE ADOPTED CALIFORNIA EMISSION PROCEDURES.



REV. 9/7/2017

ITEM NO.	PART NUMBER	DESCRIPTION	QTY.
1	AF1001	AIR FILTER 8-5/8" x 6" DIA	1
2		SCREW CLAMP, #104 (4-1/8" - 7")	1
3	AF6002	ADAPTER, AIR FILTER 4" x 6"	1
4	AF3029	HEAT SHIELD, 11-16, FORD 6.7L TURBO DIESEL	1
5	49000061	GASKET, HEAT SHIELD	60"
6	HW319	FLAT WASHER, M6	6
7	HW318	LOCK WASHER, M6	6
8	HW244	SCREW, M6 x 1.0 x 16MM	6
9	MC400H	SCREW CLAMP, #64 (3-9/16" - 4-1/2")	2
10	AF4005	COUPLER, FLEX 4" I.D. x 3" L	1
11	AF2029	INTAKE TUBE, 11-16, FORD 6.7L TURBO DIESEL	1
12	AF4047	COUPLER, STRAIGHT 4-1/2" I.D. x 2" L	1

ITEM NO.	PART NUMBER	DESCRIPTION	QTY.
13	MC450H	SCREW CLAMP, #72 (3" - 5")	2
14	AF7001	BARBED PIN, M6 x 1.0	2
15	GA139	GASKET, MAF SENSOR	1
16	HW248	SCREW, M4 x 0.7 x 12MM	2
17	AF5033	BRACKET 1, 11-16, FORD 6.7L TURBO DIESEL	1
18	AF5034	BRACKET 2, 11-16, FORD 6.7L TURBO DIESEL	1
19	HW320	FLAT WASHER, 1/4"	2
20	HW322	LOCK WASHER, 1/4"	2
21	HW115	NUT, 1/4"-20	2
22	AF5035	BRACKET 3, 11-16, FORD 6.7L TURBO DIESEL	1
23	HW245	SCREW, 1/4"-20 x 5/8"	2
24	HW521	CABLE TIE, PUSH MOUNT, 8"	4

REVIEW THE INSTRUCTIONS AND VERIFY THE KIT CONTENTS:

1. Please take a moment to read and understand these instructions before installing your Flowmaster cold air intake kit.



2. Use the parts drawing and list (front page) to verify your kit's contents.

In the unlikely event that any parts are missing, please contact FLOWMASTER Technical Support for replacements.

To simplify assembly and avoid cross-threading fasteners, identify and separate the 1/4-20 screws, (item 23) (used with nuts (21)), and the M6 screws (8) (used with filter adapter (3) and barbed pins (14)).

REMOVE THE FACTORY AIR INTAKE SYSTEM:

NOTES

- We highly recommend that you retain all factory air intake system parts.
- Please refer to vehicle manufacturer's recommendations regarding removal of factory components.
- Disconnecting the negative battery cable erases pre-programmed electronic memories. Write down all memory settings before disconnecting the negative battery cable. Some radios will require an anti-theft code to be entered after the battery is reconnected. The anti-theft code is typically supplied with your owner's manual. In the event your vehicle's anti-theft code cannot be recovered, contact an authorized dealership to obtain your vehicle's anti-theft code.

3. Turn off the vehicle's ignition and disconnect the negative battery cable.

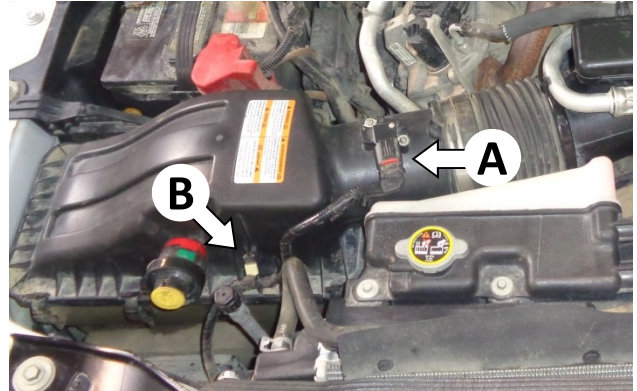

4. Disconnect the mass airflow (MAF) sensor plug (A) by pulling the locking tab away from the sensor until it stops, then squeezing the top and bottom of the plug and pulling it straight off the sensor. Then unclip the sensor lead from the airbox (B).



5. Remove the airbox mount bolt (A) and **retain for use at Step 18**. Then loosen the screw clamp securing the airbox to the intake duct (B).



6. Separate the intake duct from the airbox, then firmly pull the airbox straight up to remove it from the vehicle.



7. Remove the MAF sensor from the airbox, then remove the factory gasket from the sensor.
CAUTION: The sensor is delicate! Handle it with care, and put it in a safe place until reinstallation.

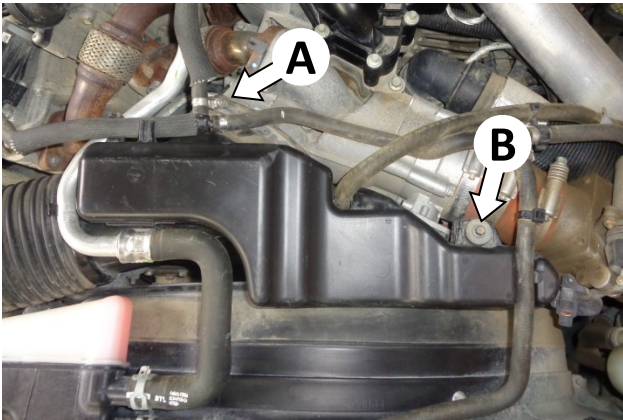

8. Loosen the screw clamp securing the intake duct to the turbocharger inlet (A). Then remove the intake duct mount bolt (B).

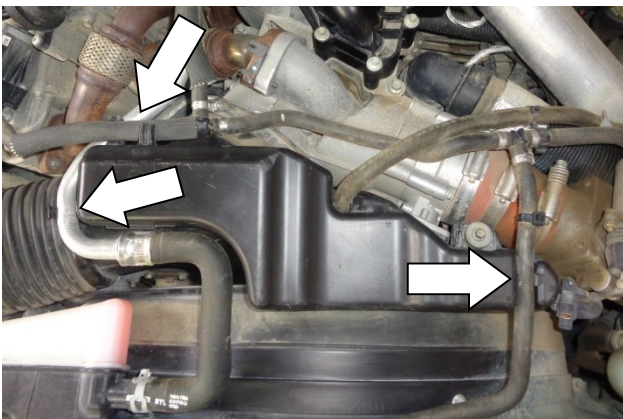

9. Release the tube and hoses from their clips at the three locations shown.



10. Separate the intake duct from the turbo inlet, then remove the duct from the vehicle.

ASSEMBLE AND INSTALL YOUR FLOWMASTER COLD AIR INTAKE SYSTEM:

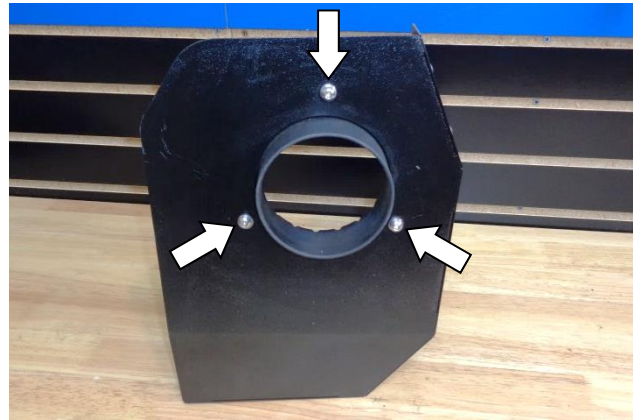

11. Assemble the air filter adapter (3) to the heat shield (4) using the M6 screws (8), lock washers (7) and flat washers (6).



12. Firmly press the gasket (5) onto the edge of the heat shield, gradually working your way around. When you return to the starting point, use metal-cutting shears to trim the gasket to length.



13. Attach bracket (18) to the heat shield using a ¼-20 × 5/8" screw (23) (against the bracket), and a flat washer (19), lock washer (20) and nut (21) (against the heat shield). **Do not tighten the bracket fasteners at this time.**



14. Attach bracket (17) at the heat shield's inner corner using a ¼-20 × 5/8" screw (23) and flat washer (19) (against the heat shield), and a lock washer (20) and nut (21) (against the bracket). Then attach a barbed pin (14) to the bracket, using an M6 screw (8), lock washer (7) and flat washer (6).



15. Attach a barbed pin (14) to the heat shield's outer corner using and M6 screw (8), lock washer (7) and flat washer (6).



16. Slip the smaller screw clamps (9) onto the flex coupler (10). Install the coupler on the air filter adapter, pushing it flush against the heat shield. Tighten only the filter adapter clamp at this time. (Leave the other clamp loose.)

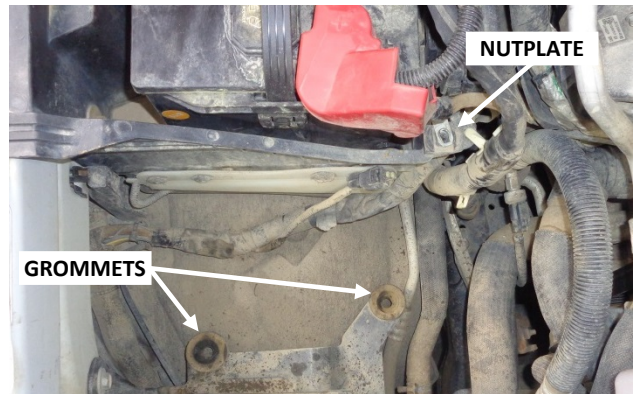

17. In the vehicle, identify the three points (two rubber grommets, and one nut-plate) to which the assembled heat shield will be mounted.

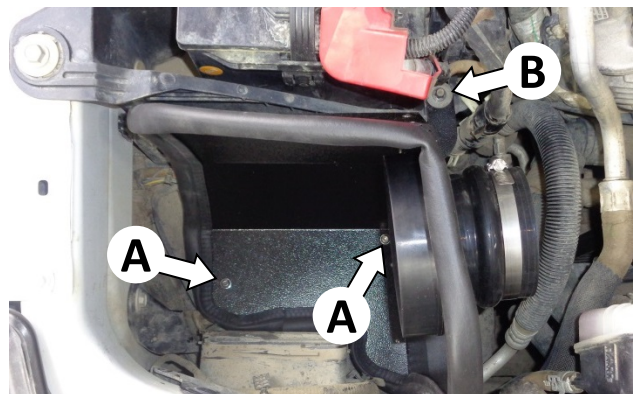

18. Install the heat shield in the vehicle by pushing the barbed pins into the rubber grommets (A). (Soapy water will ease insertion.) Then install **the stock bolt (B) removed at Step 5**. After tightening the bolt, tighten the bracket to the heat shield.



19. Slip the MAF sensor gasket (15) over the sensor, ensuring correct orientation. Then install the sensor in intake tube (11), using the M4 screws (16).



20. Slip the larger screw clamps (13) onto the straight coupler (12). Install the coupler on the oval end of the intake tube. Only snug – do not tighten – the tube clamp at this time. (Leave the other clamp loose.)

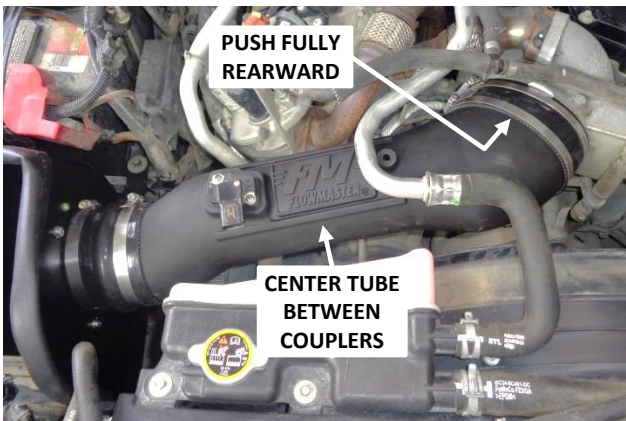

21. Install the assembled intake tube in the vehicle. Push the straight coupler up against the stops on the turbo inlet, then tighten the clamp. Then center the intake tube between the couplers, and tighten the last two screw clamps.

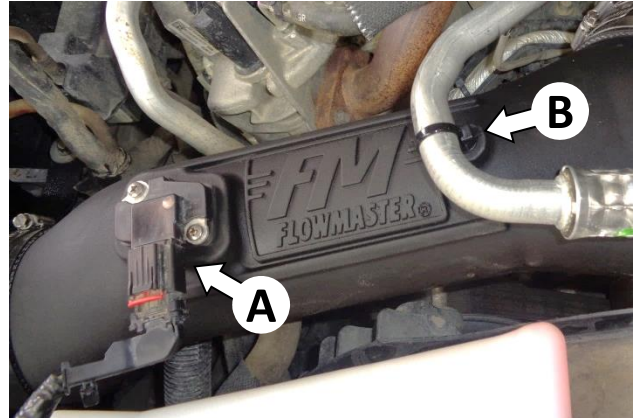

22. Reconnect the MAF sensor plug to the sensor (A), close the locking tab, and verify the connection is secure. Secure the metal tube to the intake tube (B) using cable tie (24).

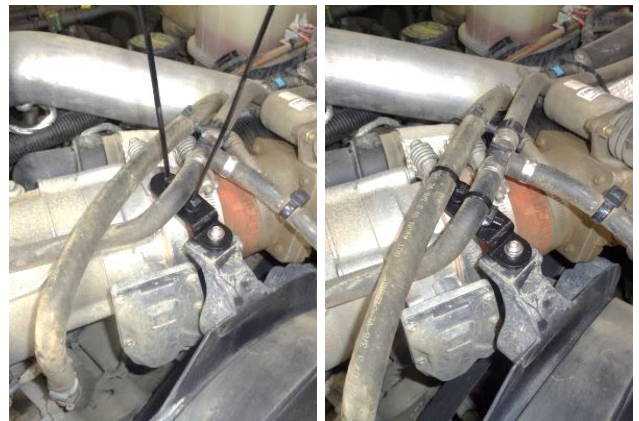

23. Attach bracket (22) to the mount point for the stock intake duct, using an M6 screw (8), lock washer (7) and flat washer (6). Then secure the two hoses to the bracket using two cable ties (24).



24. The stock cable tie that secures the coolant hard line may break during removal of the stock intake system. Your kit includes a fourth cable tie (24) to replace the stock part, if needed.

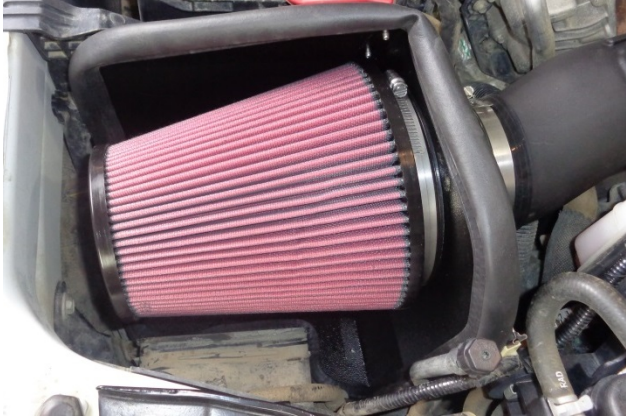

25. Install the clamp (2) on the air filter (1), then install the filter on the filter adapter and tighten the clamp.



Congratulations, the installation of your FLOWMASTER cold air intake kit is now complete!