

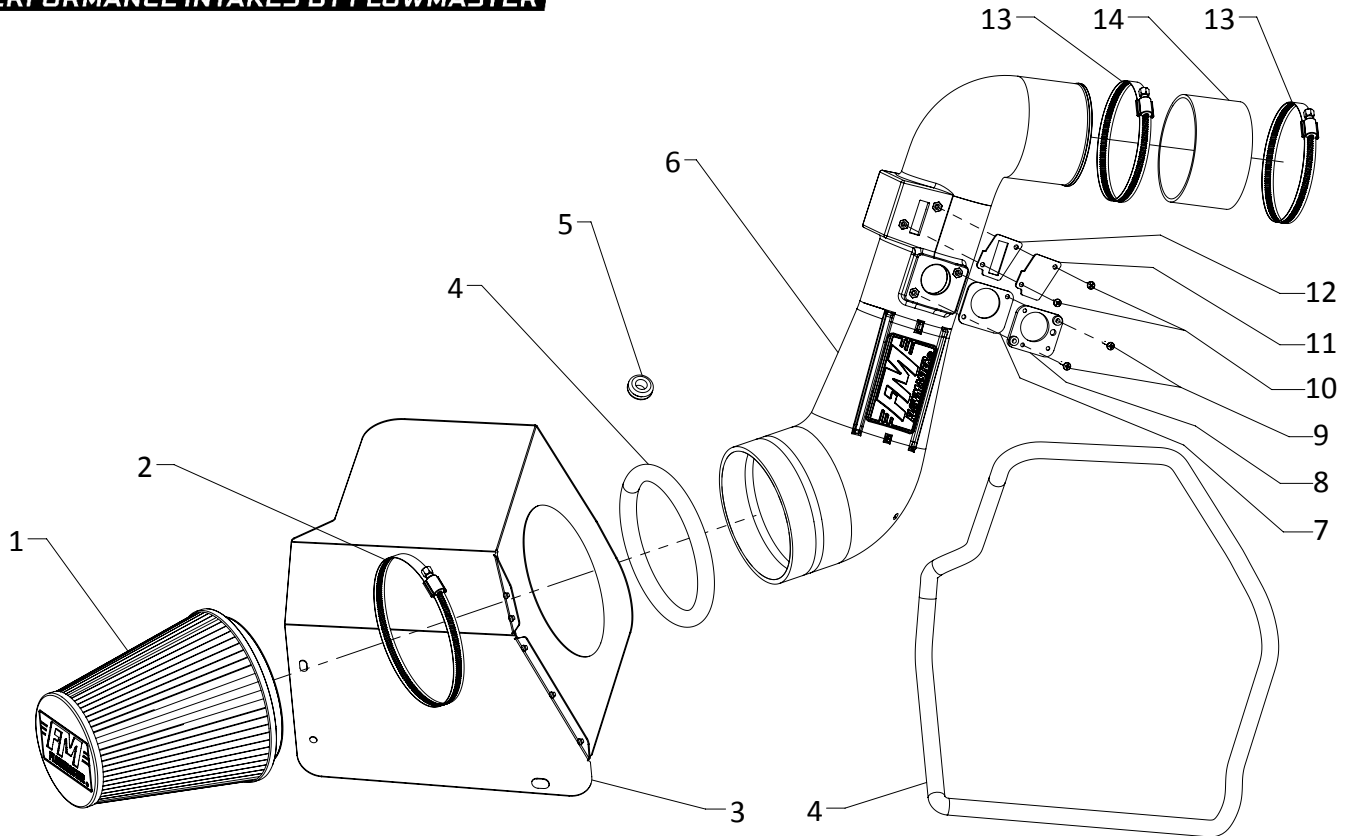

Installation Instructions for:  
**SYSTEM #615169**  
 2011-2016 Chevrolet and GMC 2500HD  
 and 3500 trucks with 6.6L Diesel engines

NOT LEGAL FOR SALE OR USE ON ANY POLLUTION-CONTROLLED MOTOR VEHICLE IN CALIFORNIA OR IN STATES THAT HAVE ADOPTED CALIFORNIA EMISSION PROCEDURES.



ITEM NO.	PART NUMBER	DESCRIPTION	QTY.
1	AF1001	AIR FILTER, 8-5/8" × 6" DIA	1
2		SCREW CLAMP, #104 (4-1/8" - 7")	1
3	AF3061	HEAT SHIELD, 11-16, GM HD TRUCKS, DURAMAX, 6.6L	1
4	49000061	GASKET, HEAT SHIELD	84"
5	AF4008	GROMMET, 1-1/16" OD × 1/2" ID × 3/16" THK	1
6	AF2061	INTAKE TUBE, 11-16, GM HD TRUCKS, DURAMAX, 6.6L	1
7	GA144	GASKET, MAF SENSOR, 09-14 GM TRUCK & SUV	1
8	AF7005	ADAPTER, MAF SENSOR, 09-14 GM TRUCK & SUV	1
9	HW255	SCREW, M4 × 0.7 × 20MM	2
10	HW248	SCREW, M4 × 0.7 × 12MM	2
11	AF5064	BLOCK-OFF PLATE, MAF SENSOR	1
12	GA139	GASKET, MAF SENSOR	1
13	MC450H	SCREW CLAMP, #72 (3" - 5")	2
14	AF4065	COUPLER, STRAIGHT 4-1/4" I.D. × 2-1/2" L	1

## REVIEW THE INSTRUCTIONS AND VERIFY THE KIT CONTENTS:

1. Please take a moment to read and understand these instructions before installing your Flowmaster performance air intake kit.



2. Use the parts drawing and list (front page) to verify your kit's contents.

In the unlikely event that any parts are missing, please contact Flowmaster Technical Support for replacements.

## REMOVE THE FACTORY AIR INTAKE SYSTEM:

### NOTES

- We highly recommend that you retain all factory air intake system parts.
  - Please refer to vehicle manufacturer's recommendations regarding removal of factory components.
  - Disconnecting the negative battery cable erases pre-programmed electronic memories. Write down all memory settings before disconnecting the negative battery cable. Some radios will require an anti-theft code to be entered after the battery is reconnected. The anti-theft code is typically supplied with your owner's manual. In the event your vehicle's anti-theft code cannot be recovered, contact an authorized dealership to obtain your vehicle's anti-theft code.
3. Turn off the vehicle's ignition and disconnect the negative battery cable. **Failure to disconnect the battery may cause the CHECK ENGINE light to illuminate after the air intake kit is installed.**

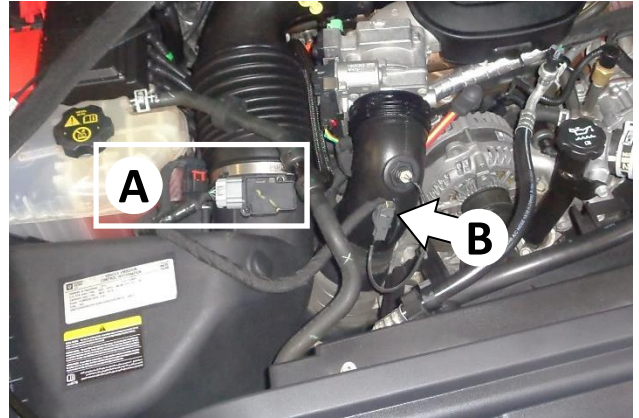

4. Note the locations of the Mass Airflow (MAF) sensor(s) (A) and the Boost Sensor connector. (2011 and 2012 vehicles have just one MAF sensor.)



5. On 2013-2016 vehicles, disconnect the plug from the small MAF sensor by lifting the latch away from the sensor, then depressing the tab inside the latch and pulling the plug straight off.



6. Disconnect the plug from the large MAF sensor by depressing the locking tab and pulling the plug straight off.





7. Disconnect the plug from the boost sensor by depressing the locking tab and pulling it straight off the connector.



8. Loosen the screw clamps that secure the air inlet duct to the airbox and the turbocharger inlet.



9. Separate the duct from the airbox and turbo inlet and remove it from the vehicle.



10. Remove the two airbox cover screws. (NOTE: The rear screw is captive and stays with the cover.) Then remove the cover from the airbox.



11. Remove the MAF sensor(s) from the airbox.  
**CAUTION: The MAF sensors are delicate!** Handle them with care, and store them in a safe location until reinstallation.



12. If your vehicle includes an air filter restriction indicator **and you intend to use it with your Flowmaster performance intake (see NOTE on page 5)**, remove it from the airbox.





13. Remove the airbox from the vehicle by pulling it firmly straight up to release it from its rubber grommets.

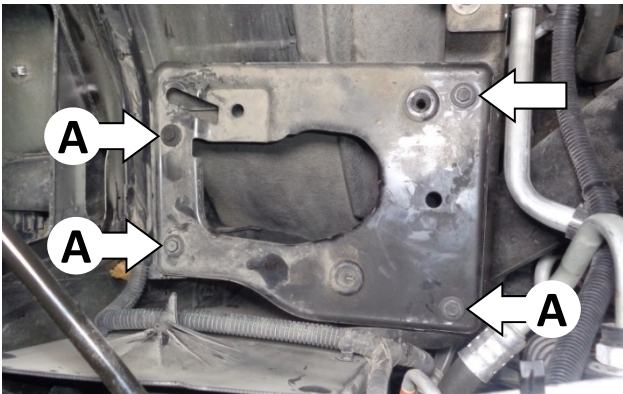

14. Remove the airbox shelf by removing its 4 mount screws. Retain the screws for reinstallation at Step 16. **NOTE: To maintain proper screw clearances at installation, note the length of the screws removed from the 3 locations marked (A) above.**

### ASSEMBLE AND INSTALL YOUR FLOWMASTER PERFORMANCE AIR INTAKE SYSTEM:



15. Attach the gasket (4) to both the opening and the outer edge of the heat shield (3) as shown. Firmly press the gasket onto the edge, gradually working all the way around. At the end point, use metal-cutting shears to trim the gasket to fit.

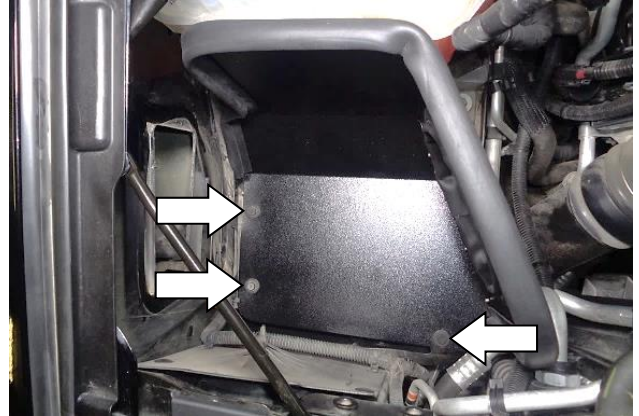

16. Use the 3 screws removed from locations (A) in Step 14 to install the heat shield in the vehicle. **NOTE: To maintain proper screw clearances, be sure to use the same length screw at each location as was removed.**

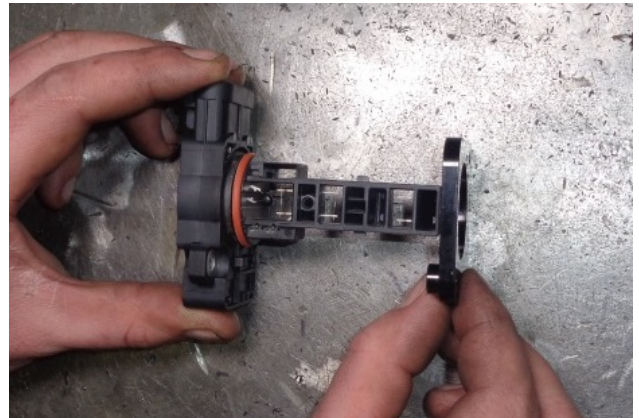

17. Install the adapter (8) over the large MAF sensor. (Lubricate the o-ring to ease installation.)



18. Install the MAF sensor gasket (7) on the sensor, ensuring correct orientation. Then install the sensor in the intake tube, using the long M4 screws (9).





19. **2013-2016 VEHICLES:** Install the MAF sensor gasket (12) on the sensor, ensuring correct orientation. Then install the sensor in the intake tube, using the short M4 screws (10).



20. **2011-2012 VEHICLES:** Install the MAF sensor gasket (12) and the block-off plate (11) on the intake tube, using the short M4 screws (10).

**NOTE RE. AIR FILTER RESTRICTION INDICATORS:**

If your vehicle's stock intake system includes an air filter restriction indicator and you want to continue using it, your Flowmaster performance intake can be modified to accept the indicator.

However, **regular maintenance of your Flowmaster filter makes use of the restriction indicator unnecessary.** We recommend that you clean and oil the filter at 25,000 mile intervals, using our Filter Refresh Kit (PN 615001). See our website or your Flowmaster distributor for details.

**Perform Steps 21-23 only if you want to modify your Flowmaster intake to accept the restriction indicator.**

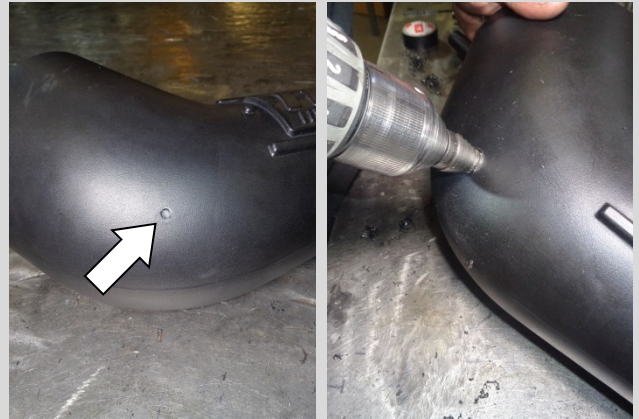

21. At the dimple in the bend of the intake tube (6), drill a 13/16" hole. **NOTE: Use of a step drill is recommended.**



22. Deburr the edge of the hole, and blow any debris out of the intake tube.



23. Insert the rubber grommet (5) into the hole. (Moistening the hole with soapy water will ease insertion.)



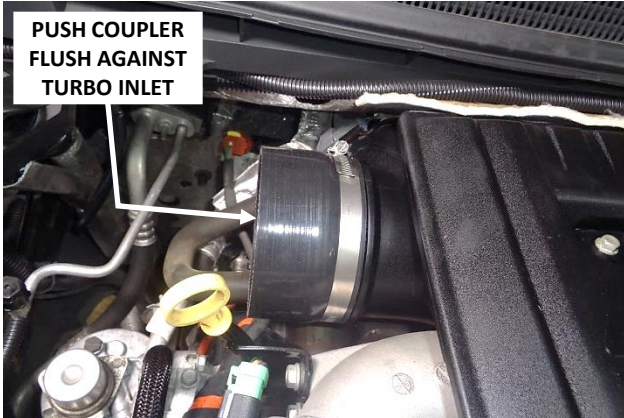

24. Install 1 small screw clamp (13) on the coupler (14). Then install the coupler on the turbocharger inlet, push it flush against the raised lip, and tighten the clamp.



27. If you are using the filter restriction indicator, insert it in the grommet. (Moistening the grommet with soapy water will ease insertion.)



25. Slip the intake tube into the heat shield.

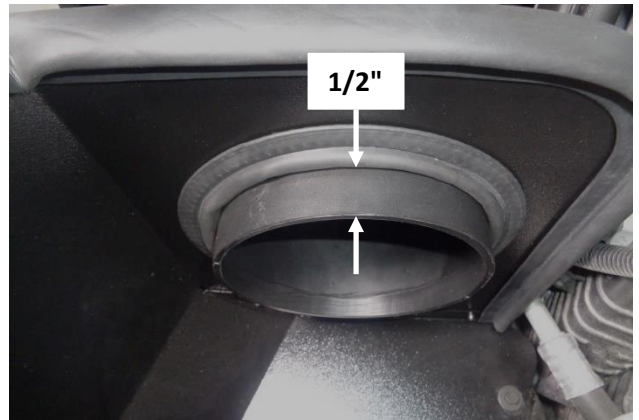

28. Align the intake tube in such a way that it protrudes approximately 1/2" into the heat shield.



26. Install the second small screw clamp (13) on the coupler, then push the intake tube into the coupler. **Do not tighten the second clamp at this time.**



29. Place the large screw clamp (2) on the air filter (1), install the filter on the intake tube, and tighten the clamp.





30. Ensure that at least 1/2" of the intake tube extends inside the coupler, then tighten the screw clamp.



31. Push the large MAF sensor plug onto the sensor until the locking tab clicks. **2013-2016 VEHICLES:** Push the small MAF sensor plug onto the sensor, then push the latch toward the sensor. Check the sensor plug(s) for security.

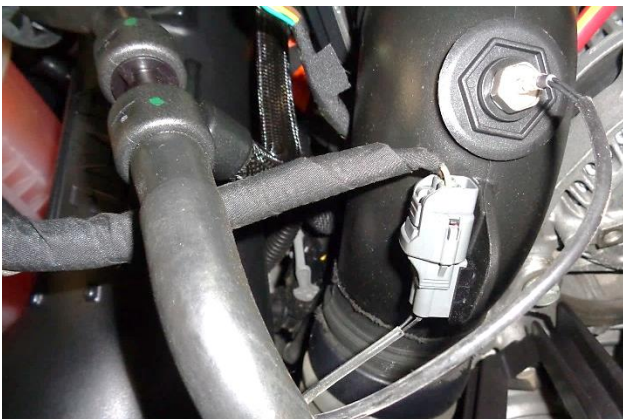

32. Push the plug onto the boost pressure sensor until the locking tab clicks, then check the plug for security.



**Congratulations, the installation of your FLOWMASTER performance air intake kit is now complete!**

#### **FILTER MAINTENANCE:**

We recommend that you clean and oil your air filter at 25,000 mile intervals using **Flowmaster's Filter Refresh Kit (PN 615001)**. See our website or your Flowmaster distributor for details.

#### **IMPORTANT: RETAIN THESE INSTRUCTIONS FOR FUTURE REFERENCE**

Flowmaster maintains a highly-trained technical service department to answer your questions, provide additional product information and offer various recommendations.

Direct all correspondence and warranty questions to:

**Flowmaster**  
100 Stony Point Rd., Suite 125  
Santa Rosa, CA 95401

**Flowmaster Technical Service: (707) 544-4761**  
**Monday – Friday: 7:30 am to 5:00 pm Pacific Time**  
**(Closed Saturday and Sunday)**

