

# INSTRUCTION MANUAL

## CAT-BACK SINGLE EXHAUST

### FORD EXPLORER 4.0L 4DR

### PART # 19686

---

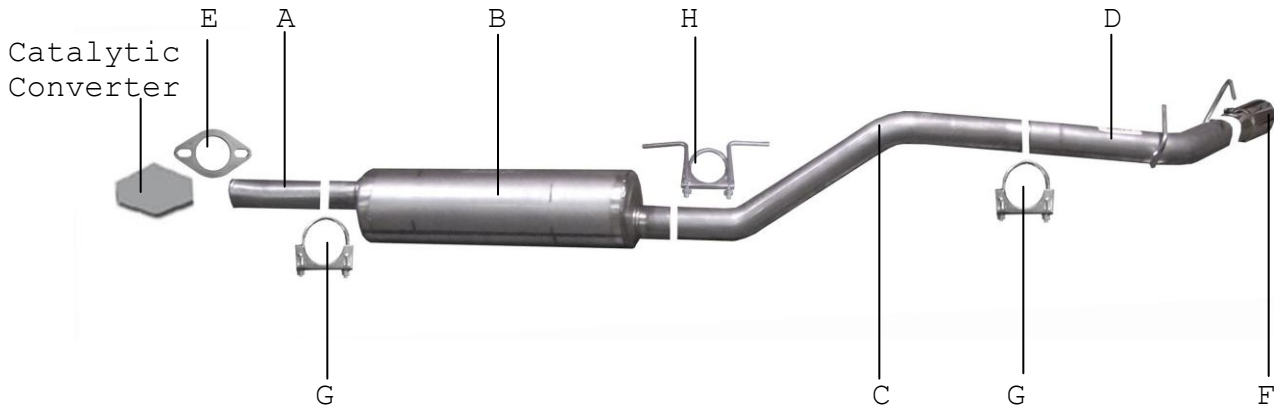

ITEM	PART #	QUANTITY	DESCRIPTION
A	09212	1	2-1/2" HEADPIPE
B	788500	1	SUPERFLOW MUFFLER
C	35002-A	1	2-1/2" OVERAXLE TAILPIPE
D	35002-2	1	2-1/2" TURNOUT PIPE
E	GP-102	1	2 BOLT FLANGE
	BO-1034	1	BOLT KIT FOR FLANGE GP-102
F	500361	1	3" STAINLESS TIP
G	5757	2	2-1/2" CLAMP
H	40019	1	O.E. MUFFLER HANGER

**WILL NOT FIT WITH RE-LOAD LEVELING SUSPENSION**

*Thank you for purchasing our GIBSON EXHAUST SYSTEM for your vehicle.  
If you need further assistance, please do not hesitate to call our Technical  
Department at (800) 528-3044, Monday through Friday, 8:00 AM to 5:00 PM.*

# EXHAUST INSTALLATION #19686

WHEN INSTALLING THIS EXHAUST SYSTEM MAKE SURE TO USE PROPER SAFETY PRECAUTIONS. BLOCK TIRES, USE JACK STANDS WHEN UNDER TRUCK, SET PARKING BRAKE, BLOCK TIRES, AND USE SAFETY GLASSES AND GLOVES. DO NOT WORK WITH HOT PIPES!

## SUGGESTED TOOLS:

15mm SOCKET, 9/16" SOCKET, 1/2" SOCKET, 1/2" WRENCH, HACKSAW

1. Lay out the GIBSON EXHAUST SYSTEM on the floor so it looks like the drawing.
2. Unbolt stock exhaust from behind the catalytic converter. Use jack stands to support converter. **You will re-use your stock head pipe bolts.**
3. Slide flange # E onto Gibson headpipe and attach to stock pipe re-using factory bolts.
4. Slide muffler # B with inlet towards the converter onto the head pipe. Use a jack stand to support the muffler and clamp down using #G (DO NOT TIGHTEN.) Rotate outlet of muffler between 4 and 5 o'clock. Muffler inlet is looking into louvers.
5. Install O.E. hanger #H into factory rubber grommets.
6. Install the over axle tailpipe #C and connect to muffler using #G hanger. (DO NOT TIGHTEN.)
7. Slide turn out pipe #D on the tailpipe behind the rear tire and clamp using #G Insert welded hanger into rubber grommet.
8. Install stainless steel tip #F. Clamp down. To clean stainless tip use a scotch brite pad and any stainless steel or aluminum cleaner.
9. Make sure there is equal clearance between sway bar and shocks.
10. When you have everything in place, tighten all bolts and clamp down.

## **SPECIAL NOTES:**

- \* MAKE SURE YOU HAVE A 1" CLEARANCE ON ALL PIPES FROM ALL RUBBER BRAKE LINES, SHOCK BOOTS, TIRES, ETC.