

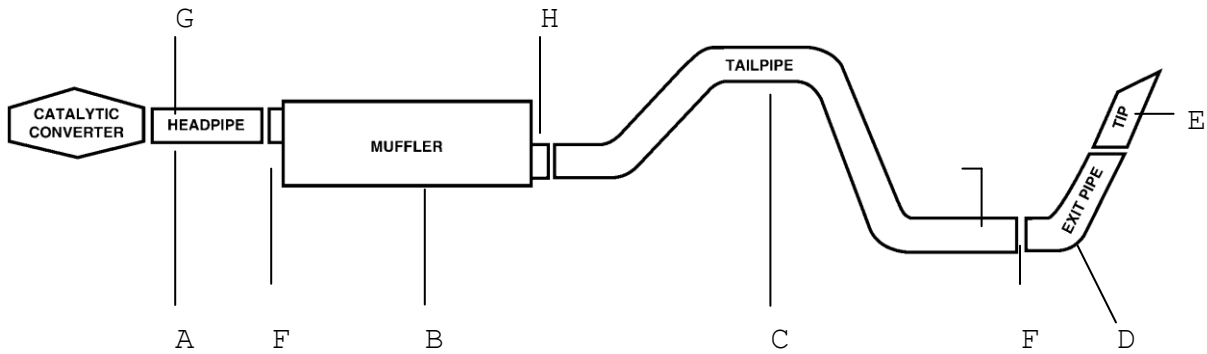

INSTRUCTION MANUAL

CAT-BACK STAINLESS SINGLE EXHAUST FORD EXPEDITION, LINCOLN NAVIGATOR 4.6L-5.4L 2/4WD 4DR

PART # 619900



ITEM	PART #	QTY	DESCRIPTION
A	123-60002S	1	3" STAINLESS HEADPIPE
B	421887	1	STAINLESS SUPERFLOW MUFFLER
C	124-70001S	1	3" STAINLESS OVERAXLE TAILPIPE
D	101-50032RS-6	1	3" STAINLESS TURNOUT PIPE
E	500360	1	3-1/2" STAINLESS STEEL TIP
F	OHD300	2	3" CLAMP
G	5757	1	2-1/2" CLAMP
H	4101	1	REAR MUFFLER T-HANGER

Thank you for purchasing our GIBSON EXHAUST SYSTEM for your vehicle. If you need further assistance, please do not hesitate to call our Technical Department at (800) 528-3044, Monday through Friday, 8:00 am to 5:00 pm.

EXHAUST INSTALLATION #619900

WHEN INSTALLING THIS EXHAUST SYSTEM MAKE SURE TO USE ALL THE PRPER SAFETY PRECAUTIONS. USE JACK STANDS WHEN UNDER TRUCK, SET PARKING BRAKE, BLOCK TIRES AND USE SAFETY GLASSES. DO NOT WORK WITH HOT PIPES!

SUGGESTED TOOLS:

HACKSAW, JACKSTAND, $\frac{1}{2}$ " WRENCH & SOCKET, 9/16" SOCKET & WRENCH, 15MM WRENCH, WD-40



LAY OUT THE GIBSON EXHAUST ON THE FLOOR SO IT LOOKS LIKE THE DRAWING. TO REMOVE YOUR FACTORY EXHAUST REMOVE IT FROM THE CLAMP LOCATED IN FRONT OF THE MUFFLER. YOU MAY NEED TO HEAT IT UP FOR EASIER REMOVAL. USE WD-40 TO AID YOU IN REMOVING HANGERS LEAVE ALL RUBBER GROMMETS IN



INSTALL TAILPIPE #C INTO MUFFLER 1 $\frac{1}{2}$ " TO 2". INSERT WELDED HANGER INTO RUBBER GROMMET. YOU WILL USE CLAMP #H TO SECURE PIPE TO MUFFLER. DO NOT TIGHTEN.



INSTALL HEADPIPE #A ONTO FACTORY PIPE. LINE UP NOTCH. USE CLAMP #G TO SECURE. DO NOT TIGHTEN.



INSTALL EXIT PIPE #D ONTO YOUR TAILPIPE. ROTATE UNTIL LEVEL. USE CLAMP #F TO SECURE. DO NOT TIGHTEN.



INSTALL MUFFLER #B 1 $\frac{1}{2}$ " TO 2" ONTO HEADPIPE WITH INLET TOWARDS THE MUFFLER. ROTATE MUFFLER UNTIL OUTLET IS AT THE 7 O'CLOCK POSTION. USE CLAMP #F TO SECURE. DO NOT TIGHTEN. NEXT, INSTALL REAR MUFFLER HANGER #H ONTO OUTLET OF MUFFLER. INSERT HANGERS INTO GROMMETS. DO NOT TIGHTEN. MUFFLER INLET IS LOOKING INTO THE LOUVERS.



INSTALL YOUR STAINLESS TIP TO YOUR DESIRED LOOK. NOW TIGHTEN ALL CLAMPS FROM THE FRONT WORKING YOUR WAY TO THE BACK.

MAKE SURE YOU HAVE A 1" CLEARANCE ON ALL PIPES FROM ALL RUBBER BRAKE LINES, FUEL LINES, SHOCKS, TIRES, PIPES, ETC.