

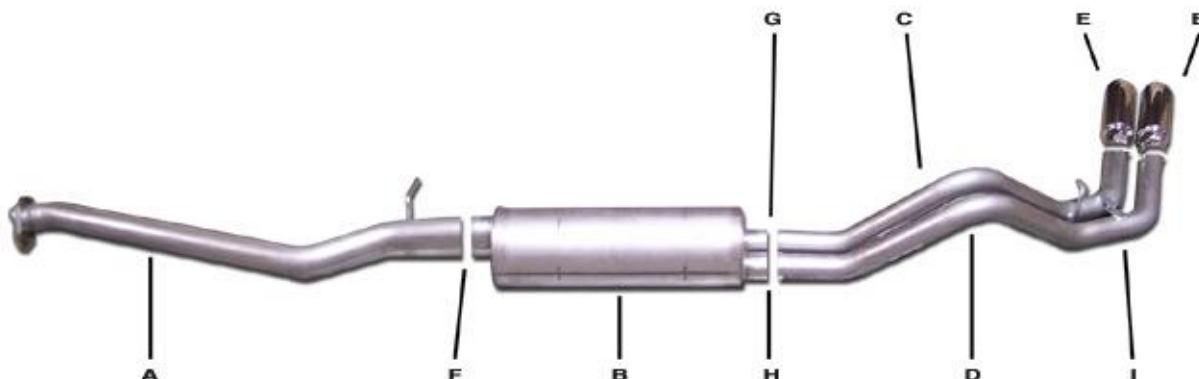

# INSTRUCTION MANUAL

## CAT-BACK DEEGAN 38 DUAL SPORT STAINLESS EXHAUST

**SILVERADO, SIERRA 1500 TRUCK**  
**EXTENDED CAB, SHORT BED, 4.3L-4.8L-5.3L 2/4 WD**  
**EXTENDED CAB, SHORT BED 4.3L, 4.8L, 5.3L 2/4WD**  
**EXTENDED CAB, SHORT BED QUAD STEER 5.3L 2WD**  
**CREW CAB, SHORT BED 1500NON-HD 5.3L 2/4WD**  
**1500 CLASSIC, CREW CAB, SHORT BED 4.8L, 5.3L 2/4WD**  
**1500 CLASSIC, EXT CAB, STANDARD BED 4.3L, 4.8L, 5.3L 2/4WD**  
**PART #65300D**



ITEM	PART #	QTY	DESCRIPTION
A	504-700394S	1	STAINLESS 3" HEADPIPE WITH FLANGE #GP-115
B	758250S	1	SUPERFLOW STAINLESS MUFFLER
C	505-700395S	1	2.5" STAINLESS PASSENGER SIDE OVERAXLE PIPE
D	506-700396S	1	2.5" STAINLESS DRIVERSIDE OVERAXLE PIPE
E	500640-B	2	4" BLACK SS TIP
F	OHD300	1	3" CLAMP
G	5757	1	2-1/2" CLAMP
H	4149	1	REAR MUFFLER HANGER
I	BO-906	1	BOLT KIT FOR TAILPIPE
J	DE-13	2	DEEGAN 38 BADGE

Thank you for purchasing our GIBSON EXHAUST SYSTEM for your vehicle. If you need further assistance, please do not hesitate to call our Technical Department at 1-800-528-3044, Monday through Friday, 8:00 am to 5:00 pm.

# EXHAUST INSTALLATION

## PART# 65300D

WHEN INSTALLING THIS EXHAUST SYSTEM MAKE SURE TO USE ALL THE PROPER SAFETY PRECAUTIONS. USE JACK STANDS WHEN UNDER TRUCK SET PARKING BRAKE, BLOCK TIRES AND USE SAFETY GLASSES. **DO NOT WORK WITH HOT PIPES!!!**

### SUGGESTED TOOLS

15mm SOCKET, 9/16" SOCKET, 1/2" SOCKET, 1/2" WRENCH, JACK STAND, WD-40



LAY OUT THE GIBSON EXHAUST ON THE FLOOR SO IT LOOKS LIKE THE DRAWING. AND COMPARE PARTS WITH MANUAL. UN-BOLT THE STOCK FLANGE BEHIND FACTORY Y-PIPE. **KEEP THE STOCK BOLTS, NUTS FOR YOU WILL RE-USE THEM.**

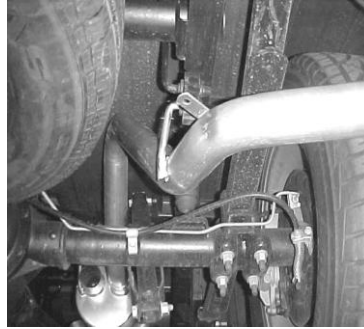

MAKE SURE MUFFLER OUTLETS ARE LEVEL BEFORE INSTALLING TAILPIPES. NOW INSTALL PASSENGER TAILPIPE #C. INSERT WELDED HANGER INTO RUBBER GROMMET.

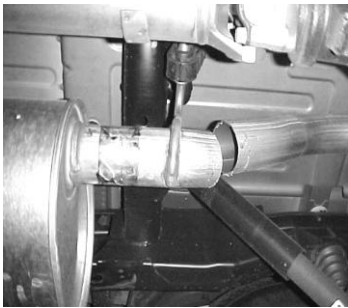

FOR EASIER REMOVAL OF THE STOCK EXHAUST CUT THE TAIL PIPE BEHIND YOUR MUFFLER. LUBE ALL RUBBER GROMMETS WITH WD-40. LEAVE ALL YOUR STOCK RUBBER GROMMETS IN PLACE.

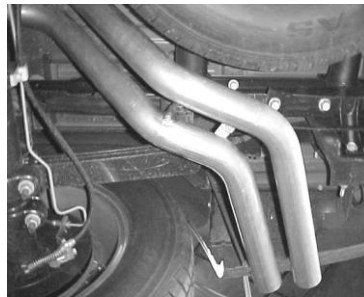

NOW INSTALL DRIVERSIDE TAILPIPE #D. THE SPARE TIRE MAY NEED TO BE LOOSENED AND PUSHED TO THE DRIVER SIDE TO ALLOW FOR CLEARANCE. USE BOLT KIT # I TO ATTACH BOTH TAILPIPES TOGETHER. DRIVERSIDE TAILPIPE BRACKET WILL BE POSITIONED ON TOP OF PASSENGER TAILPIPE BRACKET.



BOLT HEADPIPE # A TO YOUR STOCK FLANGE RE-USING FACTORY BOLTS. AND NUTS. DO NOT TIGHTEN INSERT WELDED HANGER INTO RUBBER GROMMET.



USING CLAMP #G & HANGER # H CONNECT BOTH TAILPIPES TO THE OUTLETS OF THE MUFFLER. ROTATE TAILPIPES TO BEST FIT YOUR TRUCK.



INSTALL MUFFLER # B WITH INLET TOWARDS Y-PIPE, WITH THE OUTLETS POSITIONED AT THE TOP OF THE MUFFLER. USE A JACK STAND TO SUPPORT THE MUFFLER. USE CLAMP #F TO CONNECT THE MUFFLER TO HEADPIPE. INSTALL HANGER # H ONTO THE DRIVERSIDE OUTLET OF THE MUFFLER. INSERT THE WELDED HANGER INTO THE RUBBER GROMMET FROM THE PASSENGER SIDE. DO NOT TIGHTEN.



INSTALL YOUR BLACK CERAMIC COATED TIPS. PROCEED TO THE NEXT SHEET ON HOW TO INSTALL YOUR DEEGAN 38 BADGES. AFTER YOU HAVE CHECKED FOR CLEARANCES GO BACK AND TIGHTEN ALL NUTS, BOLTS AND CLAMPS.

**"MAKE SURE YOU HAVE A 1" CLEARANCE ON ALL PIPES FROM ALL RUBBER BRAKE LINES, SHOCK BOOTS, TIRES, ETC..."**

**TORQUE ALL CLAMPS TO APPROX. 100 TO 150 FT LBS.**