

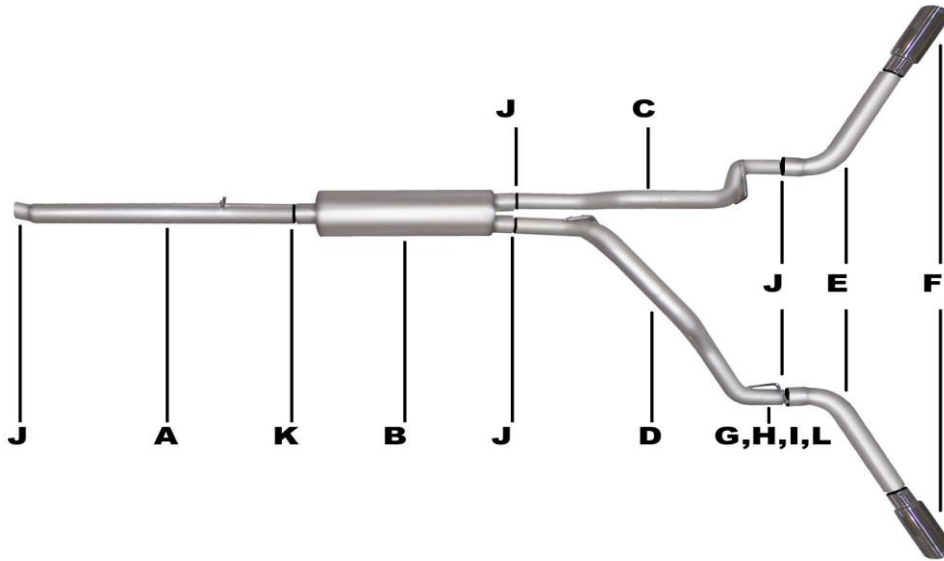

INSTRUCTION MANUAL

CAT-BACK STAINLESS DUAL EXTREME EXHAUST

Dodge Dakota Truck 3.7L-4.7L
 Quad Cab, Short Bed 2/4wd, Club Cab, Short Bed 2wd
 Mitsubishi Raider 3.7L- 4.7L
 Extended & Double Cab, Short Bed 2wd
PART # 66540



ITEM	PART #	QTY.	DESCRIPTION
A	938-700713S	1	3.00" Stainless Headpipe
B	789800S	1	SuperFlow Stainless Muffler
C	945-700714S	1	2.50" Stainless Passenger tailpipe
D	946-700715S	1	2.50" Stainless Driver Side tailpipe
E	552-700413S	2	2.50" Stainless Exitpipe
F	500374	2	3.50" Stainless tip
G	4251	1	Rear tailpipe hanger
H	4240	1	Rubber grommet
I	BO-1046	1	Bolt kit for tailpipe
J	5757	5	2.50" clamp
K	OHD300	1	3.00" clamp
L	S103	1	Tab

THANK YOU FOR PURCHASING OUR GIBSON EXHAUST SYSTEM FOR YOUR VEHICLE. IF YOU NEED FURTHER ASSISTANCE, PLEASE DO NOT HESITATE TO CALL OUR TECHNICAL DEPT. AT (800) 528-3044, MONDAY THROUGH FRIDAY, 8:00 AM TO 5:00 PM.

EXHAUST INSTALLATION #66540

When installing this exhaust system make sure to use proper safety precautions. Use jack stands when under the truck, set parking brake, block tires and use safety glasses and gloves.

DO NOT WORK WITH HOT PIPES!!

SUGGESTED TOOLS:

1/2", 9/16", 15mm Wrench & Sockets, WD-40, Jack Stand, Sawzall



LAY OUT THE GIBSON EXHAUST ON THE FLOOR AND COMPARE PART #'S TO THE PARTS LIST. TO REMOVE YOUR FACTORY EXHAUST UN-BOLT IT FROM THE TAILPIPE & THEN UN-BOLT IT FROM THE CLAMP LOCATED RIGHT AFTER THE Y-PIPE USE WD-40 TO AID YOU IN REMOVAL OF HANGERS FROM RUBBER GROMMETS. DO NOT DAMAGE YOUR OEM RUBBER GROMMETS AS THEY WILL BE USED TO INSTALL YOUR NEW GIBSON EXHAUST. **ALWAYS START AT THE FRONT AND WORK YOUR WAY BACK.**

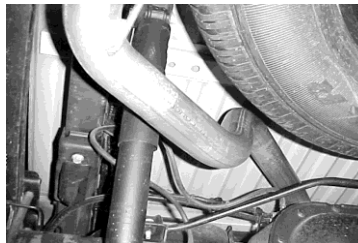

INSTALL THE DRIVER SIDE TAILPIPE #D INTO THE MUFFLER AND LEAST 1-1/2" TO 2". THIS PIPE WILL ROUTE OVER THE AXLE, BETWEEN THE SHOCK AND TIRE. USE CLAMP #J TO SECURE THE PIPE TO THE MUFFLER. **DO NOT TIGHTEN.** THEN, INSERT THE HANGERS INTO THE RUBBER GROMMETS.

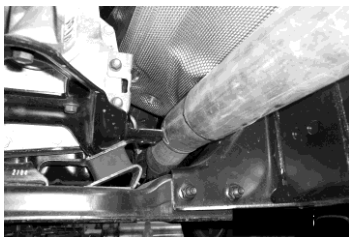

INSTALL THE 3.00" HEADPIPE #A ONTO YOUR EXISTING STOCK PIPE USE #J 2.50" CLAMP TO SECURE THE PIPES TOGETHER. **DO NOT TIGHTEN.** THEN INSERT THE WELDED HANGER INTO YOUR OEM RUBBER GROMMET.



INSTALL THE PASSENGER SIDE TAILPIPE #C INTO THE MUFFLER AT LEAST 1-1/2" TO 2". BE SURE TO INSERT THE WELDED HANGER INTO THE RUBBER GROMMET. USE 2-1/2" CLAMP #J TO SECURE THE PIPE TO THE MUFFLER. **DO NOT TIGHTEN.**



INSTALL YOUR GIBSON SUPERFLOW MUFFLER #B ONTO THE HEADPIPE #A 1-1/2" TO 2" WITH THE LOUVERS FACING TOWARD THE CONVERTER. USE A JACK STAND TO AID YOU IN SUPPORTING THE MUFFLER. THEN USE CLAMP #K TO SECURE THE MUFFLER TO THE HEAD PIPE. **DO NOT TIGHTEN.**



INSTALL EXIT PIPES #E, USE CLAMPS #J TO SECURE THE EXIT PIPES TO YOUR TAILPIPES. ROTATE THE EXIT PIPE TO THE BEST FIT ON YOUR VEHICLE INSTALL YOUR STAINLESS STEEL TIPS. *NOW GO BACK & TIGHTEN DOWN EVERYTHING ONCE YOU HAVE IT IN PLACE. TO CLEAN YOUR STAINLESS TIPS USE ANY STAINLESS CLEANER.

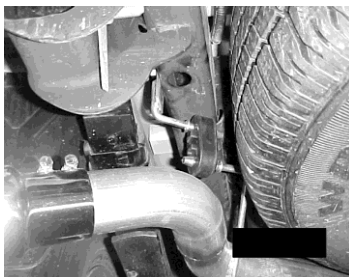

NOW MEASURE 16" FROM THE REAR OF THE FRAME. USE THIS HOLE FOR INSTALLATION OF YOUR TAILPIPE HANGER #G. USE THE BOLT KIT #I & TAB #L THAT WAS SUPPLIED, TO SECURE THE HANGER TO THE FRAME. THEN INSTALL THE RUBBER GROMMET #H ONTO THE REAR TAILPIPE HANGER

* SPECIAL NOTES:

MAKE SURE YOU HAVE A 1" CLEARANCE ON ALL PIPES FROM ALL RUBBER BRAKE LINES, SHOCK BOOTS, TIRES, ETC...