



HOOKER COMPETITION TURBO MUFFLERS

P/N	Inlet & Outlet Sizes I.D.	Case Type	Case Size Height/Width	Case Length	Overall Length
21005HKR	2 1/4"	Oval – Offset/Center	4 1/4" x 9 3/4"	14"	18 1/2"
21006HKR	2 1/2"	Oval – Offset/Center	4 1/4" x 9 3/4"	14"	18 1/2"

Thank you for making HOOKER COMPETITION TURBO MUFFLERS your choice in a high-performance muffler. Extensive dyno/track testing has enabled HOOKER to offer the most advanced design for your application. The installation, while not complex, will take a certain amount of time. However, the additional horsepower and improved performance will more than justify your efforts. The unique design of the HOOKER muffler will create a throaty powerful sound that will not change with time. Proper installation and maintenance will ensure long life and maximum performance from your HOOKER exhaust system.

BEFORE STARTING

Your vehicle must be raised a minimum of 36 inches. A floor hoist is ideal. If no hoist is available, we strongly urge the use of axle stands as a safety measure.

CAUTION! YOUR CAR SHOULD NOT BE SUPPORTED ON A BUMPER JACK.

INSTALLATION PROCEDURE: PLEASE READ CAREFULLY

NOTE: All HOOKER mufflers feature aluminized and stainless steel construction for long life. The following tips are intended to help you realize the full potential of these mufflers.

1. HOOKER mufflers are designed with a heavy gauge inlet and outlet stub for high strength. Standard muffler clamps will not properly crush the stub and welding is recommended IN ALL CASES.
2. Proper support of the exhaust system components is essential to long life. Mufflers should be supported as near the outlet as possible (See Illustration A.)
3. All exhaust system mounts should contain a rubber isolator to dampen vibration and prevent metal fatigue and cracking. Various types of mounts are available (See Illustration B for several examples.)
4. Following the above procedures should provide you with excellent service and long life from your HOOKER mufflers.

When finished, give your car a test drive checking carefully for any new noises. After several days driving, retighten all the bolts.

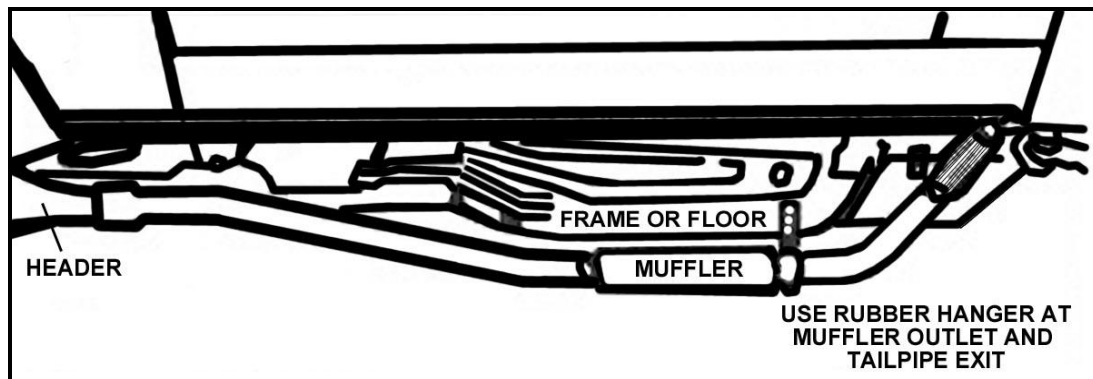

Illustration A

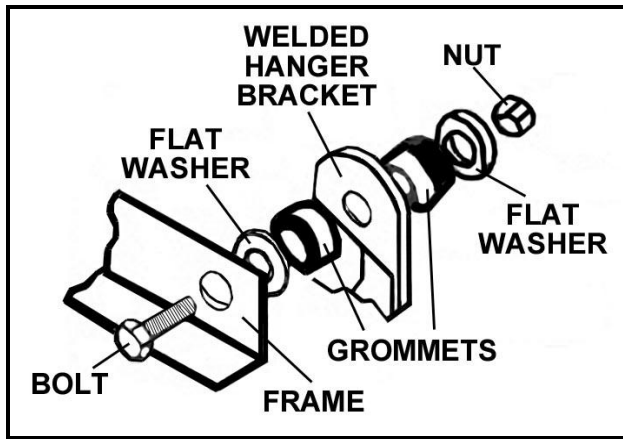

Illustration B1

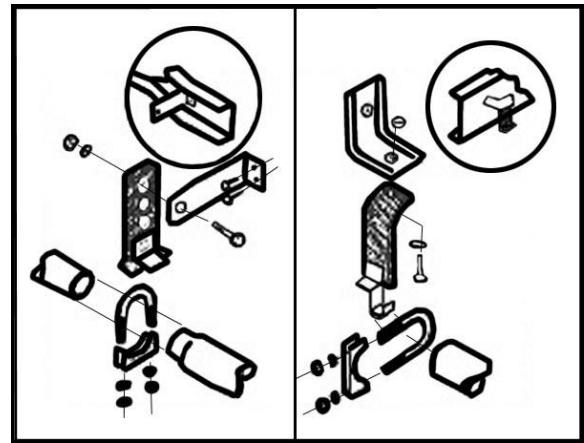

Illustration B2

LIMITATION OF LIABILITY – DISCLAIMER:

The regulation of emissions production, noise levels, and safety standards is undertaken by the federal government, each of the fifty state legislatures, and by many local municipalities, towns, and counties.

HOKKER makes no warranties of merchantability, of fitness for particular purpose, or that its products are approved for general use, or that its products are approved for general use, or that its products comply with laws, regulations, or ordinances in the state where they may be sold to the ultimate purchaser, the consumer.

Unless expressly stated to the contrary in the catalog, instruction sheet; or price list, the entire risk as to the conformity of any company product in any such state and as to repair should the product prove to be defective or non-conforming, is on the retail purchaser, the buyer, the ultimate consumer, of such product and it is not upon the seller, distributor, or manufacturer.

In this connection, the retail purchaser, the buyer, the ultimate consumer assumes the burden of the entire cost of any and all necessary service, alterations, or repair.

THE FOREGOING STATEMENT LIMITS THE LIABILITY OF THE MANUFACTURER.

HOKKER TECHNICAL SUPPORT

PHONE: 1-270-781-9741

TOLL-FREE PHONE: 1-866-GOHOLLEY

FAX: 1-270-781-9772

FOR ONLINE HELP, PLEASE REFER TO THE TECH SERVICE SECTION OF OUR WEBSITE: www.holley.com

21005HKR

21006HKR

Revision Date: 6-2-11