

Holley GM LS1/2/6, LS3, and LS7 Hi-Ram Modular Intake Manifold Kits

Holley P/N	Engine Application & Induction Configuration
300-112	LS3 Hi-Ram, Carbureted, 2 x 4500 Dominator, 2" throttle bores (sideways mount)
300-113	LS3 Hi-Ram, Carbureted, 2 x 4150 Square-Bore (inline 4160's, sideways mount 4150's)
300-114	LS3 Hi-Ram, EFI, 2 x 4500 Dominator, up to 2.25" throttle bores (side or inline mount)
300-115	LS3 Hi-Ram, EFI, 2 x 4150 Square-Bore (side or inline mount)
300-116	LS3 Hi-Ram, EFI, 1 x 92mm LS Throttle Body (longitudinal mount)
300-117	LS3 Hi-Ram, EFI, 1 x 102mm LS Throttle Body (longitudinal mount)
300-118	LS3 Hi-Ram, Carbureted, with Blank Configurable Plenum Top
300-119	LS3 Hi-Ram, EFI, with Blank Configurable Plenum Top
300-122	LS1/2/6 Hi-Ram, EFI, 1 x 92mm LS Throttle Body (longitudinal mount)
300-123	LS1/2/6 Hi-Ram, EFI, 1 x 102mm LS Throttle Body (longitudinal mount)
300-124	LS7 Hi-Ram, EFI, 1 x 92mm LS Throttle Body (longitudinal mount)
300-125	LS7 Hi-Ram, EFI, 1 x 102mm LS Throttle Body (longitudinal mount)
300-213	LS3 Hi-Ram, Carbureted, Base Manifold Only (plenum top fab. flange available)
300-214	LS3 Hi-Ram, EFI, Base Manifold Only with Fuel Rails (plenum top fab. flange available)
300-226	LS1/2/6 Hi-Ram, Carbureted, Base Manifold Only (plenum top fab. flange available)
300-227	LS1/2/6 Hi-Ram, EFI, Base Manifold Only with Fuel Rails (plenum top fab. flange available)
300-228	LS7 Hi-Ram, Carbureted, Base Manifold Only (plenum top fab. flange available)
300-229	LS7 Hi-Ram, EFI, Base Manifold Only with Fuel Rails (plenum top fab. flange available)

INSTALLATION INSTRUCTIONS 199R10572

(Before installation, please read these instructions completely.)

APPLICATIONS:

The Holley LS Hi-Ram intake manifold series is designed for GM LS Gen III and IV engines. There is a LS Hi-Ram intake manifold available for each of the three GM OE LS cylinder head types, LS1/2/6 (cathedral port), LS3, and LS7. These intake manifolds will work with OE or aftermarket cylinder heads as long as the head is configured with the intake flange bolt pattern and intake port opening locations matching the appropriate OE application, LS1/2/6, LS3, or LS7.

These Hi-Ram style intake manifolds are designed for high performance engine applications up to 427-440 cubic inch displacement and maximum engine speeds of 7500-8500 rpm, depending on the engine combination. The Hi-Ram intake manifolds are intended for maximum performance applications and will not accept stock components and hardware. A modified hood will be required for most vehicle applications.

NOTE: The EFI versions of the LS Hi-Ram intake manifold and fuel rail are designed to accept Bosch Style EV-1 or Magneti Marelli Pico fuel injectors. OE LS fuel injectors may not fit properly in the Hi-Ram EFI intake manifold fuel rail assembly. There is a kit available separately for the LS7 Hi-Ram EFI to allow the use of stock LS7 fuel injectors, P/N 300-230 (see below in the service parts section).

EMISSIONS EQUIPMENT:

Holley Hi-Ram intake manifolds do not accept any emission-control devices. This part is not legal for sale or use for motor vehicles with pollution-controlled equipment.

DIMENSIONS:

NOTE: All heights measure to the lifter valley cover flange on the engine block.

NOTE: Unless otherwise stated, the dimensions and information applies to all LS Hi-Ram applications LS1/2/6, LS3 and LS7.

- A-B Height, (Carbureted or EFI, 2x4V Top Mount & Blank) – 11.08”.
- T/R Base Plenum Top Mounting Flange Height – 8.42”
- Total Height with 92/102mm Long. Mount EFI Plenum Top – 12.32”.
- Port Size:
 - LS1/2/6 – 3.18” Height (includes injector tunnel) x 0.98” Wide.
 - LS3 – 2.49” Height x 1.21” Wide.
 - LS7 – 2.33” Height x 1.30” Wide.
- Mounting Flange Gasket Type:
 - LS3 & LS7 – 3/32” Round Viton O-Rings, Size 2-146, 2-5/8” I.D. (included with the int. man. install kit).
 - LS1/2/6 – 3/32” Round Viton O-Rings, Size 2-151, 3” I.D. (included with the int. man. install kit).
- Plenum Top Gasket Type – 3/32” Round Viton O-ring Cord (included with the intake manifold installation kit).
- Throttle Valve Flange Location, with 92/102mm Long. Mount EFI Plenum Top: Height – 8.42”, Longitudinal Location – 3.84 (forward from engine block front flange), Lateral Location – On-Center, Angle – 25 deg. (down from vertical).
- TR Runner Length and Runner As-cast Cross-sectional area:
 - LS1/2/6 – Runner Length - 6.58”
As-cast Runner CSA - Tapered, 4.25 in² at the entry to 2.53 in² at the port flange.
 - LS3 – Runner Length - 6.50”
As-cast Runner CSA - Tapered, 4.25 in² at the entry to 2.77 in² at the port flange.
 - LS7 – Runner Length - 6.31”
As-cast Runner CSA - Tapered, 4.67 in² at the entry to 2.84 in² at the port flange.

INSTALLATION KIT CONTENTS:

- ❑ 12 – ¼-20 UNC x 7/8” Long Socket Head Cap Screws, Zinc Plated, Plenum Attachment Bolts
- ❑ 4.5 ft – O-ring Cord, 3/32” Dia. Round Section Viton, Plenum Flange Seal, Holley Service P/N 508-21
- ❑ **LS3 & LS7:** 8 – O-Ring, 3/32” Dia. Round Sect. Viton, Size 2-146, 2-5/8” I.D., Port Flg Seals, Holley Service P/N 508-22
- ❑ **LS1/2/6:** 8 – O-Ring, 3/32” Dia. Round Sect. Viton, Size 2-151, 3” I.D., Port Flg Seals, Holley Service P/N 508-23
- ❑ 10 – Stud, M6 x 1.0 Threads, Intake Manifold to Cylinder Head Mounting
- ❑ 10 – Washer, M6 x 12mm O.D x 1.6mm Thick, Intake Manifold to Cylinder Head Mounting
- ❑ 10 – Nut, M6 x 1.0 Threads, Intake Manifold to Cylinder Head Mounting
- ❑ 1 – ¼ NPT Hex Steel Pipe Plug
- ❑ 1 – 3/8 NPT Hex Steel Pipe Plug
- ❑ 1 – Installation Instructions
- ❑ 1 – Warranty Card

FUEL RAIL KIT CONTENTS: (included in P/N's 300-114, 115, 116, 117, 119, 122, 123, 124, 125, 214, 227 & 229):
LS3 & LS7 – Fuel Rail Kit P/N 534-203, LS1/2/6 – Fuel Rail Kit P/N 534-204

- ❑ 2 – Fuel Rail, High Volume, Configured with ¾-16 O-ring Ports (AN-8)
- ❑ 4 – ¼-20 UNC x 1-3/4” Long Socket Head Cap Screws, Zinc Plated, Fuel Rail Mounting
- ❑ 4 – Washer, 1/4 x .50” O.D x .06” Thick, Fuel Rail Mounting
- ❑ 4 – Spacer, ¼ I.D. x ½” O.D. x 3/8” Thick, Fuel Rail Mounting

EFI PLENUM TOP, 1 x 92mm/102mm LS THROTTLE BODY, KIT CONTENTS: (incl. in 300-116, 117, 122, 123, 124 & 125):

- ❑ 1 – Gasket, 92mm/102mm LS Throttle Body, Holley Service P/N 508-20

INSTALLATION INSTRUCTIONS:

Installation on Modified Engine Components –

The Hi-Ram modular intake manifolds are designed to provide maximum performance for racing engines. The intake manifold will have the best fitment when the engine block and cylinder heads are machined to standard OE dimensions. If the engine block or cylinder head deck surfaces have been milled significantly, the alignment of the mounting bolt holes and the port flange openings to the cylinder head may be shifted and not match-up satisfactorily. If your engine has had the cylinder head or engine block deck surfaces milled, the following may be necessary for proper intake manifold installation.

- The bolt holes in the intake manifold would have to be slotted to allow the fastener to properly pass through the manifold mounting holes.
- The mounting fasteners must freely thread into the cylinder head while passing through the mounting holes or the manifold may not seat properly onto the cylinder head surfaces when the fasteners are tightened.
- As the o-ring grooves are located in the intake manifold mounting flanges, material may not be removed from the intake manifold mounting flanges without jeopardizing the sealing of the manifold. Any material removal required to align the port flange openings should be removed from the cylinder head not the intake manifold.
- When port matching the intake manifold port openings to the cylinder head openings, care should be taken not to break into or damage the o-ring groove or o-ring seal will not be effective. The intake manifold mounting surfaces on the cylinder heads should be in good condition, free of nicks or scratches, where the sealing o-rings will seat to ensure proper sealing.

Installation of the Intake Manifold Base –

NOTE: For the LS3 Hi-Ram, at two of the mounting bolt hole positions a stud is required as a fuel rail boss on each side prevents a bolt from being inserted into the bolt hole from the top. Studs are provided for the installation of all LS Hi-Ram intake manifolds. (The studs have been provided so that the threads in the cylinder heads are preserved during repeated assembly and disassembly) If it is desired to use bolts, make sure the bolts have proper thread engagement, 12 turns minimum, and also do not bottom in the cylinder head threads.

1. Before installing the intake manifold base, perform a test fit of the intake manifold without the o-rings installed. Make sure that the mounting studs supplied can thread freely into the cylinder heads through the intake manifold mounting holes. The mounting flange should seat properly.
2. Check the port opening alignment. Test fit the plenum top, fuel and vacuum plumbing, throttle linkage, wiring, etc to ensure there are not any fit issues before performing the final intake manifold installation.
3. For final installation, install the eight o-rings provided in the mounting flange o-ring grooves. To make sure the o-rings do not fall from the grooves apply a light coat of grease to the o-rings.
4. Install the mounting studs into the cylinder heads. The end with the shorter length of thread goes into the cylinder heads. Apply engine oil to the threads and thread in the stud until all of the threads are engaged by hand.
5. Put the manifold base into place on the mounting flange. Be sure that all of the o-rings are still in the grooves and are not being crushed between the flanges.

WARNING! The M6x1 threads in the aluminum cylinder head will not withstand abuse. Care must be taken to have proper thread engagement and to tighten the fasteners to the proper specifications.

6. Install the washers and nuts provided; engine oil should be applied to the threads. Gently tighten the nuts working side to side and out from center, (see the tightening sequence diagram below), until manifold is seated on the mounting flanges and the o-rings have been compressed. In two steps tighten the mounting nuts first to 50 in-lbs and then to 106 in-lbs following the tighten sequence diagram below.

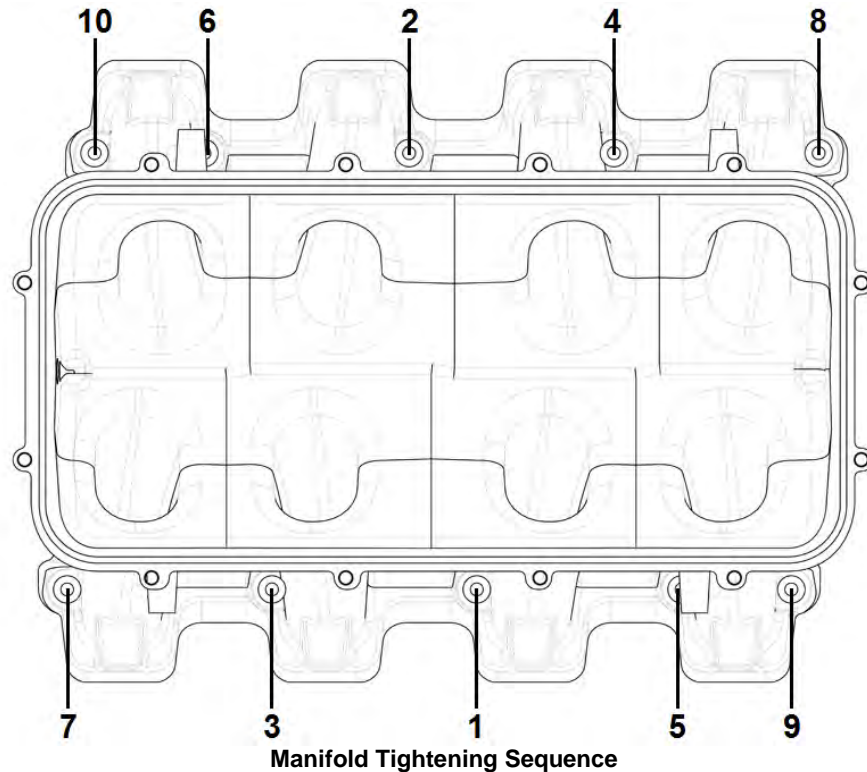

7. There is a flange on the rear of the base manifold for vacuum source. On the carbureted version, there is a 1/4 NPT port and a 3/8 NPT port. On the EFI version, there is a 3/8 NPT port and a port for a GM LS3 style MAP sensor (O-ring seal on the nipple and retained with a single bolt). There is enough room on this flange area to drill and tap additional ports as desired.

LS3 MAP sensor, GM P/N 12591290, will cover naturally aspirated (1 bar) applications; a LS9 MAP sensor (post blower), GM P/N 12592525 (red label) should cover forced induction applications up to 3 Bar. The LS3 MAP sensor does not have the same absolute pressure measurement to voltage output range as a LS1 or LS2 MAP sensor. An ECU set up for the manifold absolute pressure to voltage output of the LS1 or LS2 MAP sensor will need to recalibrate to properly operate the engine with the LS3 MAP sensor. Consult the ECU manufacturer or tuner for the proper ECU MAP sensor calibration for the MAP sensor that you plan to use.

If the use of a GM bolt-on type MAP sensor is not desired, the MAP port can be tapped 1/4 NPT, and a fitting used in the port to plumb a hose to a MAP sensor mounted at some other location. The LS1 or LS2 MAP sensor can be mounted with a simple hand-made sheet metal bracket and a hose connected to the nipple that is on the MAP sensor with the grommet seal removed.

Installation of the Plenum Top –

1. Before installing the plenum top, the supplied o-ring cord will need to be cut to length and glued together.
2. Lay the o-ring cord into the groove on the plenum flange of the base manifold with the free end overlapped.
3. Mark the position of the cut to be made across both o-ring ends.
4. Lay the o-ring on a flat surface with the ends overlapped and the marks aligned as they were when the marks were made.
5. With a sharp razor blade cut thru both ends of the o-ring at the mark simultaneously.
6. With a drop of super glue, Cyanoacrylate, bond the ends of the o-ring together. The glued joint should be smooth, not offset or kinked.
7. To ensure sealing at the glued joint apply a thin film of silicone sealer around the o-ring at the glued joint, allowing the silicone to partially cure before installation of the o-ring in the groove.
8. Install the o-ring in the groove on the base manifold plenum flange. Place the plenum top in place.

9. The plenum top flange is symmetrical so all tops will fit in either a forward or rearward orientation. For the carbureted type tops, 2 x 4500 and 2 x4150, the side with the three bosses would go towards the side for the throttle linkage, normally on the left side of the car. For the EFI top with the LS throttle body flange, the throttle body flange could go to the front or the rear, as desired.
10. Apply a drop of engine oil to and thread in the supplied ¼-20 x 7/8" long socket head capscrews through the base manifold plenum flange from the underside.
11. Gently tighten the fasteners evenly - starting from the middle of the sides, crossing side to side, and moving towards the ends until the plenum top is seated and the o-ring is compressed. Tighten the fasteners in two steps using the tightening pattern shown in the figure below. Tighten to 75 in-lbs for the first step and 130 in-lbs for the second step.

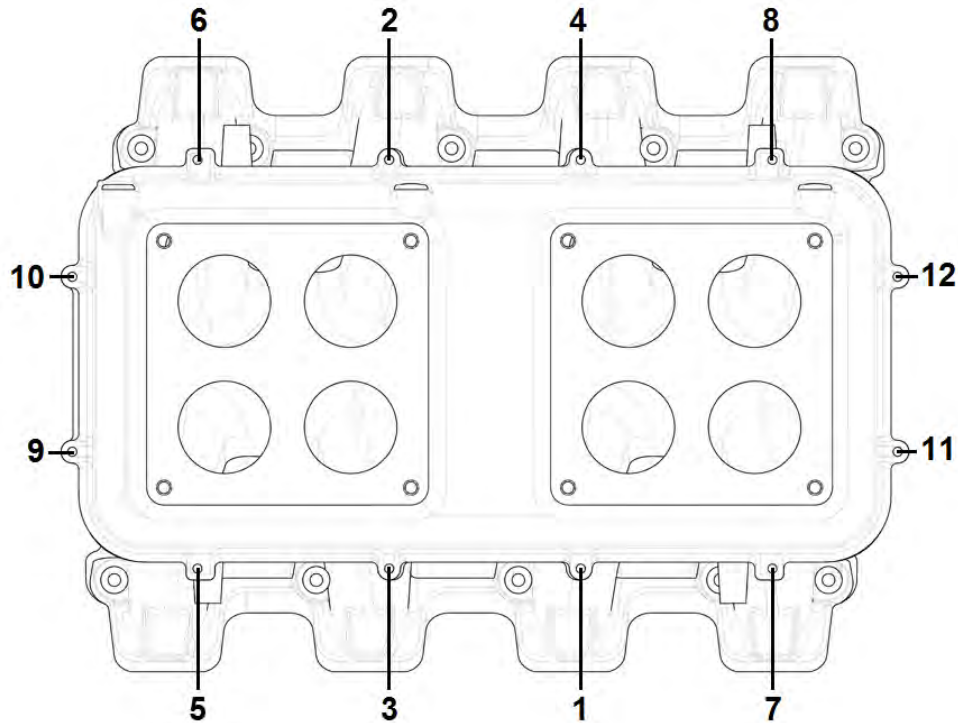

Plenum Top Tightening Sequence

Installation of the Fuel Rails –

P/N's 300-114, 300-115, 300-116, 300-117, 300-119, 300-122, 300-123, 300-124, 300-125, 300-214, 300-227 and 300-229, include a fuel rail kit. The fuel rail mounting pads have two sets of holes. The top holes position the fuel rail to install a standard Bosch style EV-1 fuel injector. The bottom set of holes position the fuel rail to install the shorter Magneti Marelli Pico style fuel injector.

1. Apply a silicone lubricant to the o-ring on the inlet end of fuel injectors and insert the fuel injectors into the ports in the fuel rail. To insert the injector without tearing the o-ring, gently rock the injector in the inlet of the port while applying pressure to insert the injector.
2. Position the injectors to properly orient the wiring plugs, apply silicone lubricant to the injector outlet o-rings, and insert all four injectors into injector bosses in the base intake manifold applying gentle downward pressure on the fuel rail. The proper orientation for the fuel rail is with the logo facing outward.
3. Once the injectors are inserted into the intake manifold, place the ¼" washers on the ¼-20 x 1.75 long socket head capscrews.
4. Apply a drop of oil to the socket head cap screws, place the spacers between the fuel rail and the mounting bosses, and thread in the socket head capscrews.
5. Tighten the fasteners in two steps, 75 in-lbs for the first step and 130 in-lbs for the second step.
6. Check and make sure the injector is floating on the o-ring; rotate the injector back and forth to confirm that there is no load on the injector body.

7. The fuel rail is designed to provide enough flow and volume to dampen fuel pressure oscillations and variations at the inlet of the fuel injectors. The fuel rails are machined to receive an adapter fitting for 3/4-16 (AN-8) o-ring port.
 - For power levels below 700-750HP AN-6 (3/8") plumbing to and from the fuel rails should be sufficient.
 - For power levels above 750Hp AN-8 (1/2") plumbing is recommended.
 - It is always recommended to only use tubular hose ends when a non-straight hose end is required.
 - The best configuration for plumbing the fuel rails is to split from the supply line with a "Y" type distribution block or fitting then feed into the inlet end of each fuel rail. The hoses from the exit end of each fuel rail would then feed into each inlet port of a fuel pressure regulator with two inlet ports or into another "Y" type distribution block or fitting connecting to a hose leading to the fuel pressure regulator.

Installation of the Carburetors or Throttle Bodies –

1. When installing the carburetors or throttle bodies and the connecting throttle linkage, check to be sure that all throttle levers and linkage components have adequate clearance from the intake manifold and plenum top components.
2. The plenum tops for the 2 x4500 and 2 x 4150 carburetor configurations have bosses for the mounting of throttle linkage. The three bosses are positioned for the mounting of heim joints that would carry a throttle linkage motion transfer shaft.
3. The EFI 1 x 92mm and 1 x 102mm LS throttle body plenum tops provide bosses near the throttle body flange for the mounting of a throttle cable bracket. The bracket will need to be fabricated by the user for each individual throttle cable and throttle body application. It should be noted that the throttle body flange on this plenum top may fitted with a GM LS3 drive by wire throttle body.

HI-RAM PLENUM TOPS AND SERVICE PARTS AVAILABLE SEPARATELY:

Plenum Tops

- 300-215 – 2 x 4500, 2" Throttle Bores, (sideways mount)
- 300-216 – 2 x 4150, up to 1.75" bores, (sideways mount 4150, inline mount 4160)
- 300-217 – Blank Flange Configurable Top
- 300-218 – 1 x 92mm LS Throttle Body, Longitudinal Mount
- 300-219 – 1 x 102mm LS Throttle Body, Longitudinal Mount
- 300-223 – 2 x 4500, up to 2.25" Throttle Bores, (sideways mount carbureted, sideways or inline mount throttle bodies)
- 300-224 – Bug Catcher Fuel Injector Hat, (blank flange top machined like the top of a 6-71 blower)

Fuel Rail Kits

- 534-203 – LS3 & LS7 Hi-Ram Fuel Rail Kit, High Volume, 3/4-16 O-ring Port (AN-8) Connection
- 534-204 – LS1/2/6 Hi-Ram Fuel Rail Kit, High Volume, 3/4-16 O-ring Port (AN-8) Connection
- 534-206 – Fuel Rail Extrusion, Raw, 12" Long, High Volume
- 534-207 – Fuel Rail Extrusion, Raw, 18" Long, High Volume
- 534-208 – Fuel Rail Extrusion, Raw, 36" Long, High Volume

Fabrication Flanges

- 300-220 – Hi-Ram Plenum Fabrication Flange, 0.50" Billet Machined Aluminum Plate
- 300-221 – Hi-Ram 92mm LS Throttle Body Fabrication Flange, 0.50" Billet Machined Aluminum Plate
- 300-222 – Hi-Ram 102mm LS Throttle Body Fabrication Flange, 0.50" Billet Machined Aluminum Plate

Service Parts

- 508-20 – Throttle Body Gasket, 92mm or 102mm LS Throttle Body
- 508-21 – Hi-Ram Plenum O-Ring Cord, 3/32" Round, Viton, 4.5' Long
- 508-22 – LS3 & LS7 Hi-Ram Port Flange O-Rings, 3/32" Round, Size 2-146, Viton, set of 8
- 508-23 – LS1/2/6 Hi-Ram Port Flange O-Rings, 3/32" Round, Size 2-146, Viton, set of 8
- 300-225 – Stud Kit, LS3 Hi-Ram Base Intake Manifold Mounting
- 300-230 – Fuel Rail Mount Adapter Kit, for using GM LS7 Injectors on the LS7 Hi-Ram

NOTE: The 300-230 adapter kit can also be used on LS1/2/3 and LS3 Hi-Ram IM but drilling and tapping more bolt holes on the fuel rail mounting bosses is required; consult the 300-230 installation instructions for specifics.

**Holley Technical Support
1801 Russellville Road
Bowling Green, KY 42101
1-866-GOHOLLEY
270-781-9741
www.holley.com**

© 2011 Holley Performance Products, Inc. All rights reserved.

**199R10572
Revision Date: 5-14-12**