



**StealthRam™ Small Block Chevy
Multi-Port EFI Systems
Standard and Vortec Intake Versions**



- 550-821** (Early/Late Heads)
- 550-822** (Early/Late Heads) Polished
- 550-826** (Vortec Heads)
- 550-827** (Vortec Heads) Polished



**HARDWARE AND FUEL SYSTEM
INSTALLATION MANUAL
P/N 199R10554**

NOTE: These instructions must be read and fully understood before beginning installation. If this manual is not fully understood, installation should not be attempted. Failure to follow these instructions, including the pictures, may result in subsequent system failure.

TABLE OF CONTENTS:

1.0 INTRODUCTION	3
2.0 BEFORE YOU BEGIN	3
3.0 WARNINGS, NOTES, AND NOTICES	3
4.0 SKILL LEVEL REQUIRED	4
5.0 ADDITIONAL ITEMS REQUIRED FOR INSTALLATION	4
6.0 TOOLS REQUIRED FOR INSTALLATION	4
7.0 PLANNING THE INSTALLATION	4
8.0 REMOVAL OF EXISTING FUEL SYSTEM	4
8.1 Preparing the Manifold for Installation	5
8.2A Installation of the STEALTHRAM™ Manifold (Standard Manifold)	5
8.2B Installation of the STEALTHRAM™ Manifold (Vortec Manifold)	6
8.2C CONTINUE HERE AFTER COMPLETING SECTION 8.2A OR 8.2B	6
8.3 Installing the Distributor	9
8.4 Vacuum Line Connections	9
9.0 SUPPLY AND RETURN FUEL SYSTEM INSTALLATION	10
9.1 Fuel Supply/Return System Description	10
9.2 Fuel Pressure Regulator	10
9.3 Fuel Pump Installation	11
9.4 Fuel Line Mounting	11
9.5 Fuel Filters	12
9.6 Return Line Installation	12
9.7 Oxygen Sensor Installation	13
9.7.1 Oxygen Sensor Mounting Procedure	13
9.6.2 ECU Mounting	14
10.0 WIRING	14
10.1 Important Wiring “Do’s and Don’ts”	14
11.0 WIRING HARNESS INSTALLATION	14
11.1 Main Power/Battery Connection	14
12.0 PRIMARY HARNESS INSTALLATION AND SENSORS CONNECTION	15
12.1 ECU Connectors	15
12.2 Harness Routing	15
12.3 Sensor Connections & Outputs	16
12.3.1 Throttle Position Sensor (TPS)	16
12.3.2 Manifold Air Pressure Sensor (MAP)	16
12.3.3 Coolant Temperature Sensor (CTS)	16
12.3.4 Manifold Air Temperature Sensor (MAT)	16
12.3.6 Wide Band Oxygen Sensor (WB02)	16
12.3.7 Fuel Pressure (Fuel)	17
12.3.8 Oil Pressure (Oil)	17
12.3.9 CANbus – Handheld (CAN)	17
12.3.10 Knock Sensor (Knock)	17
12.3.11 Ignition (IGN) –	18
13.0 PRIMARY OUTPUTS	18
13.1 Idle Air Control (IAC)	18
13.2 Fuel Injector Outputs (INJ) and Fuel Injector Harness	18
14.0 LOOSE WIRES	18
15.0 IGNITION/ENGINE SPEED INPUT	19
16.0 IGNITION/ENGINE SPEED INPUT WIRING	20
17.0 ADDITIONAL OUTPUTS	23
APPENDIX 1.0	24
Pinout	24

1.0 INTRODUCTION

Congratulations on your purchase of the **STEALTHRAM™** multi-point fuel injection kit! Holley has written this manual for the installation of the **STEALTHRAM™** manifold and fuel system. Wiring harness and ECU installation, sensor connections, startup, and tuning are contained in a separate manual for the Avenger system or on the disc supplied with HP systems. . Please read all the **WARNINGS, NOTES, and TIPS**, as they contain valuable information that can save you time and money. For information or parts assistance, please contact technical service at 1-270-781-9741, M-F, 8-5 CST. Have the part number of the product you purchased ready when you call.

WARNING! The **STEALTHRAM™** system consists of a number of sophisticated components. Failure of any one component does not constitute, nor does it justify, warranty of the complete system. Individual service items are available for replacement of components. If assistance is required or if you need further warranty clarification, you can call Holley Technical Service at the number shown above.

WARNING! To preserve warranty, these instructions must be read and followed thoroughly and completely before and during installation. It is important that you become familiar with the parts and the installation of the **STEALTHRAM™** system, before you begin. Failure to read and understand these instructions could result in damage to **STEALTHRAM™** components that is not covered by the warranty and could result in serious personal injury and property damage.

WARNING! Use of leaded fuels will degrade the oxygen sensor and will result in incorrect exhaust gas oxygen readings and improper fuel delivery. Failure to follow these directions does not constitute the right to a warranty claim.

WARNING! Failure to follow all of the above will result in an improper installation, which may lead to personal injury, including death, and/or property damage. Improper installation and/or misuse of this or any Holley product will void all warranties.

WARNING! Use of some RTV silicone sealers will destroy the oxygen sensor used with this product. Ensure that the RTV silicone sealant you use is compatible with oxygen sensor vehicles. This information should be found on the RTV package.

2.0 BEFORE YOU BEGIN

Fuel injection systems have proven to increase engine performance by allowing the engine to operate to the best output it is capable of producing. Make sure your engine is in good basic running order before installing the **STEALTHRAM™** fuel injection system.

Anything that increases the power of your engine demands more from all the components and systems. If your engine is in poor condition before you begin this installation, you won't get the results you want.

Fuel injection is more efficient, but also less forgiving than a carburetor. A properly tuned EFI system can disclose hidden problems your carburetor may have concealed. Corroded terminals or a weak battery, alternator, or ignition system will not adversely affect your carburetor, but they will interfere with the precision functions of an EFI system.

The engine cooling system must have a working 160°F to 210°F thermostat.

3.0 WARNINGS, NOTES, AND NOTICES

WARNING! For the safety and protection of you and others, only a trained mechanic that has adequate fuel system experience must perform the installation, adjustment, and repair. It is particularly important to remember one of the very basic principles of safety: fuel vapors are heavier than air and tend to collect in low places where an explosive fuel/air mixture may be ignited by any spark or flame resulting in property damage, personal injury and/or death. Extreme caution must be exercised to prevent spillage and thus eliminate the formation of such fuel vapors.

WARNING! These instructions are provided as a general guideline for installation. You must use your own judgment to determine whether the engine's, or your safety will be endangered by any procedure selected. You should consult factory engine manuals to ensure compliance with fastener torque and other important specifications unique to each engine.

WARNING! This type of work **MUST** be performed in a well-ventilated area. Do not smoke or have an open flame present near gasoline vapors or an explosion may result.

4.0 SKILL LEVEL REQUIRED

Installation of the **STEALTHRAM™** intake system and the ECU requires approximately the same level of skill and experience to replace or service an induction system consisting of a carburetor and conventional intake manifold (as well as basic wiring skills for the installations of the ECU).

Adequate skills for modifying the vehicle fuel supply are critical, and will vary widely, depending upon the selected components and methods of fuel line plumbing. The most basic level will require the user to plumb a high-pressure supply fuel line and a tank-return fuel line to the fuel rails. The most complex level may require the user to modify the fuel tank, re-route or add fuel lines, or mount various combinations of electrical and/or mechanical fuel pumps. Some fabrications may be required, depending on applications, for throttle cable assemblies, throttle cable bracket, and thermostat housings.

NOTICE: If you are not absolutely certain that you have the skills and experience required to perform these procedures, we strongly recommend you have this system installed and tested by a technician with specialized training in EFI and fuel systems service.

5.0 ADDITIONAL ITEMS REQUIRED FOR INSTALLATION

The following is a list of materials that are needed, depending on the application.

- 3/8" fuel hose (must meet SAE J30)
- 3/8" steel fuel line (must meet SAE J526)
- Assorted vacuum plugs
- Various Electrical Connectors
- TPI throttle and trans cables and bracket
- Intake gaskets (FelPro #1205 for std heads and Vortec gaskets for Vortec systems)
- Teflon pipe sealing compound
- Heat shrink
- RTV sealant (O₂ sensor compatible)
- Intake bolts for std intake or Vortec intake

6.0 TOOLS REQUIRED FOR INSTALLATION

The following is a list of materials that are needed, depending on the application.

- Standard wrench set
- Medium blade screwdriver
- Drill and assorted bit sizes
- #2 Phillips screwdriver
- Allen wrench set
- Gasket scraper
- Hole saw (2")
- 10" adjustable wrench
- Torque wrench
- Timing/advance light

7.0 PLANNING THE INSTALLATION

Before starting the installation of the **STEALTHRAM™** system, several things must be decided.

- Mounting location of the fuel pump & fuel filters
- Routing of the fuel supply line from the tank, to the filter, to the pump
- Routing of the high-pressure fuel supply line from the pump to 10micron fuel filter to the fuel rails on top of the manifold
- Routing of the fuel return line from the pressure regulator to the fuel tank
- Mounting location of the ECU
- Proper throttle cable installation
- Proper thermostat housing clearance

8.0 REMOVAL OF EXISTING FUEL SYSTEM

1. Disconnect the ground side of the battery.
2. Drain the cooling system. Remove the cooling system hoses and thermostat housing.

DANGER! FAILURE TO RELEASE FUEL PRESSURE COULD RESULT IN UNINTENTIONAL FUEL SPRAY, WHICH COULD CAUSE A FIRE HAZARD OR SERIOUS PERSONAL INJURY.

DANGER! BEFORE DISCONNECTING OR REMOVING FUEL LINES, MAKE SURE THE ENGINE IS COLD. DO NOT SMOKE. EXTINGUISH ALL OPEN FLAMES. AN OPEN FLAME, SPARK, OR EXTREME HEAT NEAR GASOLINE COULD RESULT IN A FIRE AND/OR EXPLOSION CAUSING SERIOUS INJURY OR DEATH!

3. Drain the fuel tank. Disconnect the fuel supply line or disconnect the fuel supply line and plug the hose. Disconnect all throttle linkages.
4. Identify or number the ignition wires. Numbering the ignition wires will help in reconnecting them during MPFI system assembly. Remove the ignition wires from the coil and spark plugs.
5. Remove the ignition cables and distributor cap as one unit.
6. Note the position of the rotor and the distributor housing. Mark the rotor position on the distributor and mark the distributor housing position on the engine block to ensure accurate re-assembly. After marking the position of the rotor and distributor, remove the distributor. It is easiest if the rotor points directly towards the firewall.
7. Loosen all the manifold bolts before removal. Remove the manifold bolts.

DANGER! FROM THIS POINT FORWARD, USE EXTRA CAUTION TO ENSURE THAT NO GASKET MATERIAL OR OTHER FOREIGN MATTER ENTERS THE OIL PASSAGES, HEAD PORTS, OR ANY OTHER LOCATION WHERE AN OBSTRUCTION MIGHT CAUSE DAMAGE.

8. Remove the existing manifold. If required, remove the valve covers. Remove the mechanical fuel pump and push rod. Install the mechanical fuel pump block-off plate (included).

8.1 Preparing the Manifold for Installation

1. Protect the lifter galley with clean shop rags. Close off the ports by stuffing them with clean shop rags.

WARNING! Failure to cover the intake opening with a clean towel could result in dirt or debris entering the engine. Dirt or debris in the induction system can cause engine damage, which may require a complete engine overhaul.

2. Using a gasket scraper, remove the gasket material from the heads and block. When all loose material is removed, carefully remove the shop rags from the ports, ensuring that no material falls into the passages. Using a shop vac, remove all debris from the lifter gallery.
3. Inspect carefully. Use a flashlight to inspect the interior of all air, oil, and water passages.
4. Soak a clean shop rag with solvent, and clean all sealing surfaces. Surfaces must be completely clean to ensure a reliable seal between the components and gaskets.

8.2A Installation of the STEALTHRAM™ Manifold (Standard Manifold)

WARNING! USE THIS SECTION ONLY IF USING A STANDARD MANIFOLD! Skip to Section 8.2B if you have a Vortec manifold.

WARNING! Use new gaskets. Be sure you are using the proper gasket for your engine for aluminum manifolds.

1. The manifold comes with the rails, fittings, and crossover loosely installed in the proper locations. The crossover line will have to be removed in order to install the intake manifold bolts. The injectors, fittings, rails, and crossover should be assembled and tightened after the manifold is installed on the engine.
2. Install the manifold gaskets, carefully following the instructions provided by the gasket manufacturer.
3. Use O₂ sensor-compatible RTV (again following the manufacturer's instructions) around all water passages and for end seals, if the end seal gaskets are not used.
4. Carefully position the manifold on the heads, so the bolt holes in the manifold are centered over the bolt holes in the heads.
5. Handstart all the bolts.
6. Torque down the manifold bolts in the sequence in Fig. 1a and torque in gradual steps to 30 ft./lbs. Re-torque after the engine has been run.

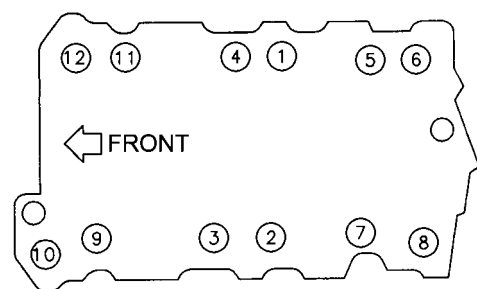

MANIFOLD TIGHTENING SEQUENCE

Figure 1a

8.2B Installation of the STEALTHRAM™ Manifold (Vortec Manifold)

WARNING! USE THIS SECTION ONLY IF USING A VORTEC MANIFOLD! Go back to Section 8.2A if you have a standard manifold.

WARNING! Use new gaskets.

NOTE: If the engine is a 1996 or later Gen 1 GM block, you must install a coolant bypass line from the intake manifold to the water pump. The bypass should run to the passenger's side outlet on the water pump using a 5/8" hose.

1. The manifold comes with the rails, fittings, and crossover loosely installed in the proper locations. The crossover line will have to be removed in order to install the intake manifold bolts. The injectors, fittings, rails, and crossover should be assembled and tightened after the manifold is installed on the engine.
2. Install the manifold gaskets, carefully following the instructions provided by the gasket manufacturer.
3. Use O₂ sensor-compatible RTV (again following the manufacturer's instructions) to lay a 1/4" bead or RTV on the engine block china walls that overlaps the intake gasket at the 4 corners.
4. Carefully position the manifold on the heads, so the bolt holes in the manifold are centered over the bolt holes in the heads.
5. Apply 242 (Blue) Loctite™ to the intake bolt threads. The intake bolts should be a 1/4-20 x 1-1/2" fastener.
6. Handstart all the bolts.
7. It is very important that the intake manifold is torqued properly or damage to the gasket will occur. Tighten all eight bolts, in the sequence shown in Figure 1b to 30 inch/pounds. Then tighten to 60 inch/pounds. Finally tighten to 132 inch/pounds (132 inch/pounds = 11 foot/pounds).

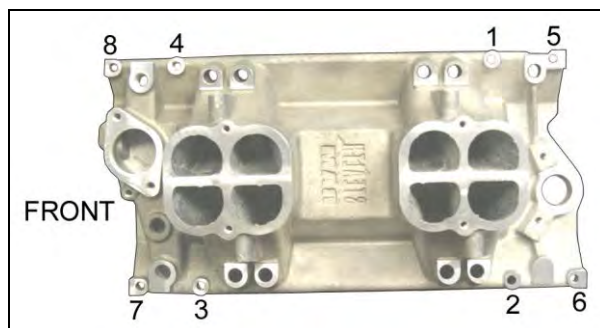

Figure 1b

8.2C CONTINUE HERE AFTER COMPLETING SECTION 8.2A OR 8.2B.

1. Remove the fuel rails. The fuel injectors are contained in a separate package in Avenger kits. Lubricate the fuel injector top and bottom O-rings with an O-ring lubricant or motor oil and place the injectors in the fuel rails. Do not use synthetic, animal, or vegetable oils. Be care not to damage the O-rings.

WARNING! Damage of the O-ring can cause fuel leakage. A fuel leak may result in a fire or an explosion hazard, which could cause serious injury or death.

2. Carefully install the injectors into the rails and then install the injectors and both rails into the manifold. Reinstall the four 1/4-20 x 1" Allen head screws that held the rails in place and tighten securely.
3. The rear driver's side fuel rail should have a -6/-6AN fitting already installed. The rear passenger side fuel rail should have a -6 plug installed. See Figure 2. Make sure these fittings are tight.

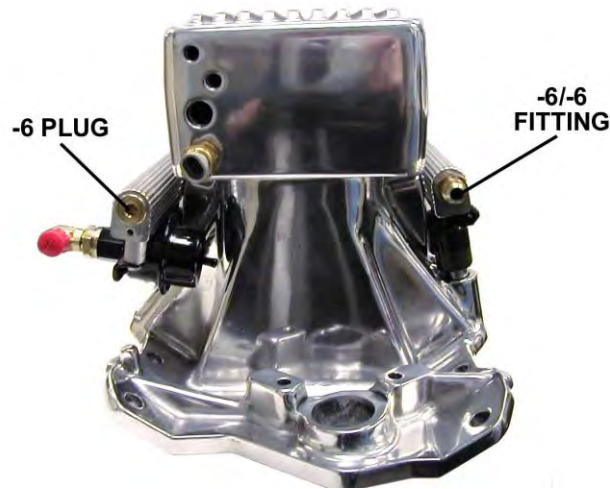

Figure 2

4. The front of each rail should have 90 degree fittings. Do not tighten them yet. Reattach the front crossover tube. Tighten completely hand tight.
5. After the front crossover tube is installed hand tight, tighten the nut on the two front 90 degree fittings.
6. Securely tighten the front crossover tube with a wrench. See Figure 3.



Figure 3

7. Install the Schrader valve to the front of the fuel rail, if not already installed. Use Teflon tape or liquid Teflon sealer. If you are going to install a fuel gauge of some sort that does not use the Schrader valve into this port, do so at this time.
8. The regulator should already be installed. Make sure that the two Allen head screws securing it to the fuel rail are tight. Also, check that the regulator fitting is tight and is pointed in the desired direction. Do not overtighten the fitting in the regulator or it will leak.
9. The upper manifold will be installed next. There is a 3/8-18 NPT hole on the underside of the upper manifold that needs to be plugged if it is not used. Do this before the manifold is installed. There is a plug included. There are two 3/8-18 NPT and two 1/8-27 NPT holes in the rear of the manifold. The two 1/8-27 NPT should be used for the MAP sensor and the fuel pressure regulator reference hose. Barbed fittings are included for this. The one 3/8-18 NPT fitting is used for the manifold air temperature sensor (gray/white connector). The other 3/8-18 NPT hole can be used for power brakes and other accessories. There is a 3/8-18 NPT plug included, if this hole is not needed. These fittings can be installed now or later.
10. Install the upper manifold with the gaskets provided. It is advised to use a light amount of adhesive or sealant on the gaskets. Install the four stainless 5/16-18x4 socket head cap screws. Torque to 18-20 ft./lbs.
11. The Idle Air Control motor (IAC) will be installed on the throttle body next. Use the M4 x .7 x 20mm SS Allen head screws and washers provided. Use the provided gasket. Tighten the adapter securely. See Figure 4.

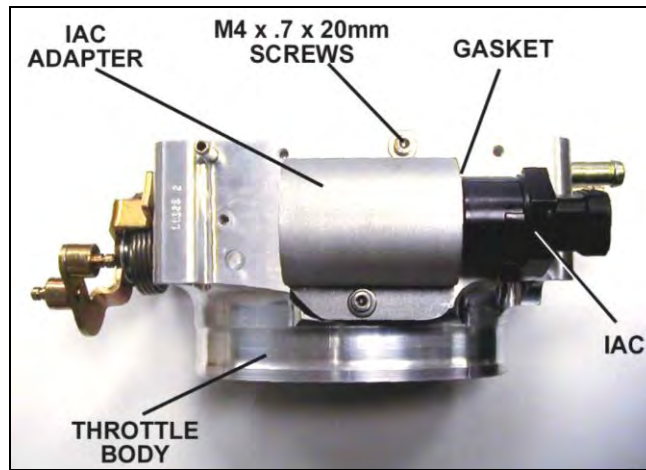

Figure 4

12. Next, install the throttle body. Use the supplied hardware and gasket that comes with the throttle body.
13. Install the coolant temperature sensor (black connector) into a coolant passage. The driver's side front of the intake is an ideal spot. Use Teflon tape or sealer on it.
14. Install the new thermostat housing gasket. Replace the thermostat housing. Replace the coolant hoses. Refill the cooling system.
15. The throttle linkage can be attached next. The **STEALTHRAM™** system uses a TPI-style throttle body. Brackets and cables for a TPI engine should be used. The following specify P/Ns, if new ones are needed.

Throttle Cable Mounting Bracket	Lokar	GM
	TCB-40TP1	14083307
	TCB-40TP2	
	TCB-40TP3	
	TCB-40SP	

Throttle Cable	TC-1000TP	14080202
-----------------------	-----------	----------

GM and Lokar can also supply transmission cables.

16. Mount the MAP sensor. It can be mounted on the firewall near the back of the intake manifold. Do not mount it so that the vacuum line is facing up. The sensor should be mounted so that condensation can not enter the sensor. This would damage the sensor or cause engine performance problems.
17. Mount the TPS sensor. Use the supplied M4.5 screws with lockwashers. See Figure 5.



Figure 5

8.3 Installing the Distributor

Follow the manufacturer's recommended procedures for the following steps:

1. Drop in the distributor, making sure that the rotor aligns with the marks made during disassembly. If you are installing a new distributor, you will have to make sure it is properly timed.
2. Align the distributor housing with the marks made on the block during disassembly.
3. Ensure the distributor seats properly against the manifold.
4. Ensure the distributor shaft is fully engaged in the oil pump.
5. Bolt the distributor hold-down clamp to the manifold.
6. Replace the distributor cap.
7. Replace the spark plug wires and check that they are in the correct firing order.

8.4 Vacuum Line Connections

1. Vacuum line needs to be run from the back of the manifold to the MAP sensor and to the fuel pressure regulator. See Figure 6. The MAP sensor should be mounted such that it is above the vacuum connection in the intake so that condensation does not run into the sensor. The map sensor vacuum inlet should be pointed at a downward angle or at worst horizontal as it would be if it were mounted to the firewall.
2. There is a vacuum port on the bottom of the throttle body. It can be used or plugged.
3. The throttle body has two large fittings on the side. The top is for the PCV inlet air, if needed. The lower can be connected to a PCV valve.



Figure 6

9.0 SUPPLY AND RETURN FUEL SYSTEM INSTALLATION

9.1 Fuel Supply/Return System Description

The high-pressure fuel supply system consists of the following sub-systems: the fuel pick-up, the coarse fuel pump pre-filter, the high-pressure electric fuel pump, the 10micron high pressure fuel filter, and the feed line (See Figure 3). The fuel pick-up delivers fuel from the tank to the inlet of the fuel pump pre-filter. From the filter, the fuel line supplies filtered fuel to the high-pressure pump inlet. The high-pressure electric fuel pump delivers pressurized fuel to the 10micron fuel filter, which in turn delivers filtered pressurized fuel to the fuel rails, fuel injectors, and the fuel pressure regulator. The function of the regulator is to maintain a constant fuel pressure of 300kPa (43.5psi). The outlet of the regulator returns the excess fuel back to the fuel tank.

The following section covers the installation of an in-line pump. The pump included with the Avenger system is Holley PN 12-920. Holley includes both a pre and post filter with the HP MPFI system. Both of these filters are designed to connect to an EFI pressure rated rubber hose. They are not designed for "AN" style plumbing. If AN lines and fittings are used, obtain AN style filters. AN fittings are available for the 12-920 pump. PN 26-160 contains two -6 pump fittings and PN 26-180 contains two -8 pump fittings.

All of the fittings on the intake manifold are -6 AN fittings (except the internal threads of the fuel pressure regulator which have a "Saginaw" thread). There are barbed adapters included that can be installed on the inlet and return fittings that can be used to connect to high pressure rated rubber fuel hose.

9.2 Fuel Pressure Regulator

The function of the fuel pressure regulator is to provide constant fuel pressure for the fuel injectors. Constant fuel pressure is essential to ensure an accurate fuel metering process. The fuel pressure regulator of the system is set to 300kPa (43.5 psi) to match the flow characteristics of the fuel injectors. The pressure regulator is referenced to the manifold pressure to ensure the required differential pressure for the metering event. Thus, at high manifold vacuum (i.e. idle) the fuel pressure gauge will read a fuel pressure that is slightly lower than 300kPa (43.5 psi) because the gauge is referenced to atmospheric conditions and not to the intake conditions. The pressure reading at idle will vary with the application as manifold vacuum changes from engine to engine and from application to application. The fuel pressure regulator included is adjustable. To adjust the fuel pressure: remove the vacuum reference line and turn the screw clockwise to increase the pressure (or counter-clockwise to decrease the fuel). The Avenger systems are programmed to work with a fuel pressure of 43 PSI.

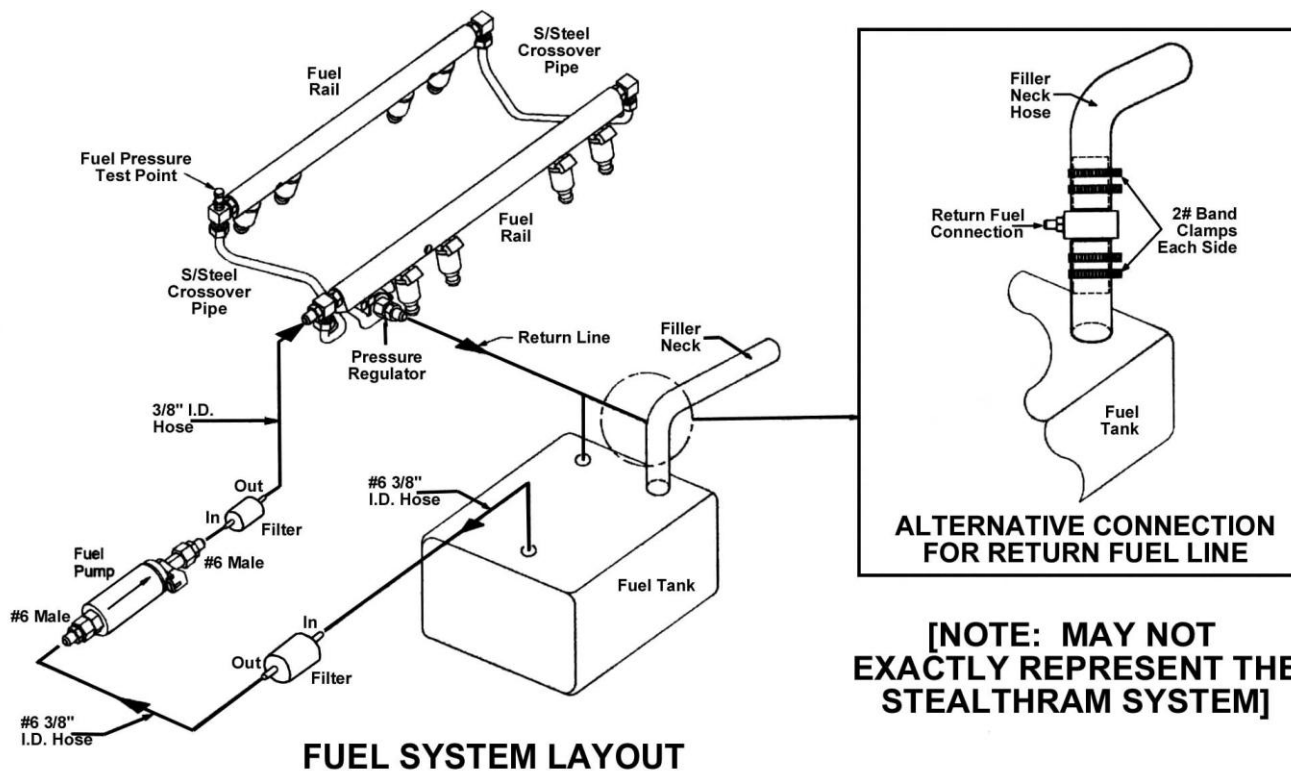

FUEL SYSTEM LAYOUT

Figure 7

9.3 Fuel Pump Installation

DANGER! NEVER GET UNDER A VEHICLE SUPPORTED ONLY BY A JACK. SERIOUS INJURY OR DEATH CAN RESULT FROM VEHICLES FALLING OFF OF JACKS. BEFORE WORKING UNDERNEATH A VEHICLE, SUPPORT SOLIDLY WITH JACK STANDS.

Most high-pressure fuel pumps have limited suction characteristics, so they need to be mounted as low as possible and should be mounted no higher than the bottom of the fuel tank. The pump can be mounted either horizontally or vertically. When mounting the fuel pump, check to make sure that you have the fuel flow in the correct direction. This may sound like a foolish reminder, but it is a common installation error. To prevent damage to the fuel pump before the fuel system is filled with fuel, drip/spray some light lubricant (such as 10w-30 motor oil) into the inlet side of the pump.

1. Make sure fuel tank is properly vented.
2. Mount the electric fuel pump as close to the fuel tank outlet as possible with the bracket provided. Mounting the fuel pump in this manner will ensure that the pump will prime easily and purge fuel vapors in the fuel lines to ensure faster starts.

DANGER! TAKE PRECAUTIONS TO ENSURE THAT ALL FUEL LINE ROUTINGS ARE AWAY FROM HEAT SOURCES, SUCH AS THE ENGINE, CATALYTIC CONVERTER, OR EXHAUST PIPES. A FIRE OR EXPLOSION HAZARD COULD CAUSE SERIOUS INJURY OR DEATH.

DANGER! ENSURE THAT THE FUEL PUMP MOUNTING LOCATION WILL NOT INTERFERE WITH ANY UNDER-THE-VEHICLE COMPONENTS, ESPECIALLY AT THE EXTREME LIMITS OF THE SUSPENSION TRAVEL. A FIRE OR EXPLOSION HAZARD COULD CAUSE SERIOUS INJURY OR DEATH.

3. Connect the pump to the tank using 3/8" I.D. fuel hose and fuel line. Connect the outlet of the pump to the steel line, which runs to the front of the vehicle with 3/8" I.D. fuel hose, depending on the diameter of the steel fuel line. All fuel hose used must meet SAE J30 performance standards. See fuel filters information below.

9.4 Fuel Line Mounting

DANGER! FAILURE TO USE A FUEL HOSE THAT MEETS SAE J30 STANDARDS COULD RESULT IN FUEL LEAKS. A FUEL LEAK MAY RESULT IN A FIRE OR EXPLOSION HAZARD, WHICH COULD CAUSE SERIOUS INJURY OR DEATH.

1. If using the existing fuel lines, inspect and replace any hose, clamp, or fuel line showing any sign of aging or not meeting SAE J30 fuel hose specifications. If you are not using the existing fuel lines, you will need a fuel line routed to and from the engine compartment and fuel rails. Use a 3/8" steel fuel line available at any auto parts store. Any steel fuel line must meet SAE J526 standards. Any time a rubber hose is connected to a steel fuel line, the steel fuel line must have a "barb" or "nipple" on it to properly retain the hose (along with hose clamps). Either use the proper tool to put a "nipple" on the end of the tube (similar to the ends of the fuel filters), or use a compression fitting and a barbed fitting adapter that is the proper size for the lines used. Clamping a rubber hose to a steel line that has the end squarely cut off does not ensure a safe connection. The inlet to the fuel rail is a -6 male fitting. A -6 female fitting can be used to connect to it. A 3/8" barbed fitting is included that connects to the -6 male that allows the connection of a rubber fuel hose that meets J30 performance standards.

DANGER! FAILURE TO USE A STEEL FUEL LINE THAT MEETS SAE J526 STANDARDS COULD RESULT IN FUEL LEAKS. A FUEL LEAK MAY RESULT IN A FIRE OR EXPLOSION HAZARD, WHICH COULD CAUSE SERIOUS INJURY OR DEATH.

DANGER! TAKE PRECAUTIONS TO ENSURE THAT ALL FUEL LINE ROUTINGS ARE AWAY FROM HEAT SOURCES, SUCH AS THE ENGINE, CATALYTIC CONVERTER, OR EXHAUST PIPES. A FIRE OR EXPLOSION HAZARD COULD CAUSE SERIOUS INJURY OR DEATH.

DANGER! RIGID FUEL LINE TUBING SHOULD BE USED FOR UNDER VEHICLE RUNS, SUCH AS A LONG VEHICLE FRAME RAILS OR UNDER FLOOR PANS. FAILURE TO DO SO IS A POTENTIAL FIRE OR EXPLOSION HAZARD, WHICH COULD CAUSE SERIOUS INJURY OR DEATH.

2. Anchor all fuel lines securely to solid chassis members at 1 ½ foot intervals, using rubber coated steel clamps. Use of only approved steel fuel line tubing will afford maximum fuel line protection against road hazards, gravel bombardment, and premature wearing due to flexing, temperature extremes, road salt, weather, etc.

9.5 Fuel Filters

WARNING! It is very important the fuel filters have the proper flow capacity, burst pressure rating, and filter size. The flow capacity of the filters must be at least 60 gallons per hour (gph), and the filter size must be no bigger than 10 microns for the high fuel pressure filter and not bigger than 75 microns for the fuel pump inlet filter. The high-pressure fuel filter should be rated for at least 150 psi burst pressure.

DANGER! FAILURE TO USE A HIGH-PRESSURE FUEL FILTER LINE RATED FOR A MINIMUM OF 100 PSI BURST PRESSURE COULD RESULT IN FUEL LEAKS OR BURSTING OF THE FUEL FILTER. A FUEL LEAK MAY RESULT IN A FIRE OR EXPLOSION HAZARD, WHICH COULD CAUSE SERIOUS INJURY OR DEATH.

The fuel filters supplied by Holley meets or exceeds the above specifications. Most filters for carburetor systems do not.

The fuel pump inlet filter (marked WIX 33033) must be plumbed between the fuel tank and the fuel pump. It should be mounted as close to the fuel tank as possible and should be mounted no higher than the top of the fuel tank. The high-pressure fuel filter should be plumbed between the fuel pump and the fuel rail. It should be mounted as close to the fuel rail as possible, but should not be mounted above the fuel rail level.

Be careful to ensure that the suction part of the fuel system contains no air leaks. Air leaks are caused by holes and/or crevices so small that they will not leak fuel. Just because fuel is not leaking out, does not mean air is not leaking in. Common causes of air leaks are not using thread-sealing compound on fittings and cracks or holes in fuel lines. Air leaks could potentially cause fuel pump failure and or inadequate fuel supply to the fuel rails.

9.6 Return Line Installation

DANGER! DO NOT USE THE VAPOR CANISTER LINES AS A FUEL RETURN LINE. POSSIBLE FUEL LEAKS MAY CREATE A FIRE OR EXPLOSION HAZARD, CAUSING SERIOUS INJURY OR DEATH.

WARNING! Use only an approved steel fuel line. The return fuel line should enter the fuel tank at the “fuel level sending unit flange” or at the “filler neck”. The connection should be made below the flapper valve of the filler neck. The filler neck or sending unit must be removed from the tank to perform this operation.

DANGER! PROPER INSTALLATION OF THE FUEL RETURN LINE MAY REQUIRE THE COMPLETE REMOVAL OF THE FUEL TANK. THIS WORK SHOULD BE DONE BY A FUEL TANK SPECIALIST, WHO REGULARLY DOES THIS WORK AND IS FAMILIAR WITH SAFETY REGULATIONS AND PRECAUTIONS NECESSARY TO DO THIS WORK. IF A PERSON ATTEMPTS THIS WORK WHO IS NOT FAMILIAR WITH THE SAFETY REGULATIONS AND PRECAUTIONS, AN EXPLOSIVE HAZARD MAY RESULT, CAUSING SERIOUS INJURY OR DEATH.

The fuel return line from the fuel pressure regulator must go back to the fuel tank and enter the fuel tank with a fitting that has an internal diameter of at least 3/8".

The fitting on the regulator is a -6 male fitting. A -6 female fitting can be connected to it. A 3/8" barbed fitting is included that attaches to the regulator to allow for rubber fuel hose to be connected to it that meets J30 performance standards.

The internal thread on the fuel pressure regulator is a “Saginaw” style thread and is internally sealed with an O-ring. This fitting should not be over-tightened in the regulator or it will leak.

Returning fuel should be routed back to the tank away from the fuel tank pick-up tube. This will allow air bubbles from the returned fuel to dissipate, before they are drawn into the pick-up tube.

There are several options, including the following, which meet the above criteria for returning the fuel to the fuel tank.

- Use a fitting already in the fuel tank.
- Use the vent fitting. Be very careful not to block the fuel vapor from escaping the tank.
- Route the return line into the filler neck. This can be done by cutting the filler neck, inserting a welded "T" fitting, and securing the neck with multiple clamps.
- Drill and weld a new fitting into the tank.

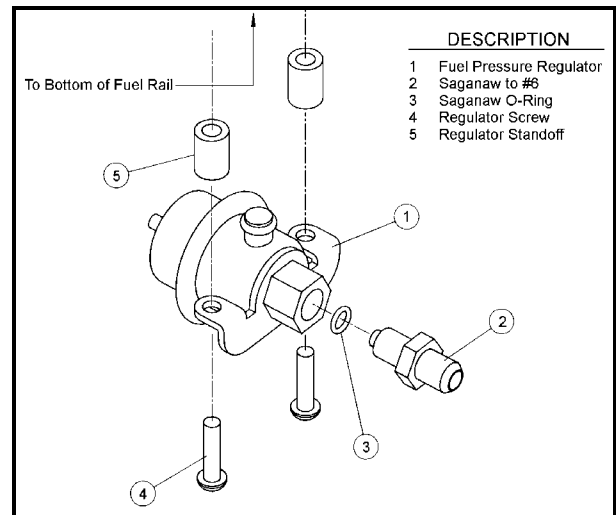

Figure 8

NOTICE: For the best performance of your fuel supply system, an in-tank pump is recommended. Such an installation can be achieved by either buying a late model fuel tank or have your tank modified by a professional company that installs an in-tank pump with the required swirl pods and baffles.

DANGER! MODIFICATIONS TO FUEL TANKS SHOULD BE DONE BY A FUEL TANK SPECIALIST, WHO REGULARLY DOES THIS WORK AND IS FAMILIAR WITH THE SAFETY REGULATIONS AND PRECAUTIONS NECESSARY TO DO THIS WORK. IF A PERSON ATTEMPTS THIS WORK WHO IS NOT FAMILIAR WITH THE SAFETY REGULATIONS AND PRECAUTIONS, AN EXPLOSIVE HAZARD MAY RESULT, CAUSING SERIOUS INJURY OR DEATH.

9.7 Oxygen Sensor Installation

9.7.1 Oxygen Sensor Mounting Procedure

NOTE: Never run the engine with the oxygen sensor installed if it is not plugged in and powered by the ECU, or it will be damaged. If you need to plug the hole temporarily, use an O2 sensor plug or a spark plug with an 18mm thread.

NOTE: Someone should install the oxygen sensor boss that has experience welding exhaust systems. Any competent exhaust shop is able to perform this task at a minimal cost.

WARNING! Use of leaded fuels will degrade the oxygen sensor over time and will result in incorrect exhaust gas oxygen-content readings.

WARNING! Use of some RTV silicone sealers will destroy the oxygen sensor used with this product. Ensure that the RTV silicone sealant you use is compatible with oxygen sensor vehicles. This information should be found on the RTV package.

Avenger EFI systems come with a Bosch wideband oxygen sensor. Make sure your sensor looks like the following picture:



1. Locate a position for the oxygen sensor as close to the engine as possible. If your vehicle has catalytic converters, the oxygen sensor **MUST** be located between the engine and the catalytic converters. Good locations are in the drop pipe, or in the “Y” pipe on single exhaust systems. Pick a location that allows easy installation of the oxygen sensor, but will protect the sensor from road hazards.

NOTE: You must have at least 3 feet of exhaust pipe after the location the oxygen sensor is mounted. If you do not the sensor will get a false lean reading at idle.

2. Drill a 7/8” hole in the location picked for the sensor. Weld the threaded boss into the 7/8” hole. An old spark plug with matching threads will avoid thread damage during the welding process. Weld all the way around the boss to insure a leak proof connection. Install the oxygen sensor into the threaded boss and tighten securely. It is a good idea to add anti-seize to the threads to aid in removal.
3. On vehicles equipped with an AIR pump, the oxygen sensor must be mounted before the AIR injection into the exhaust, or the AIR pump must be disconnected. Holley recommends that if the AIR is injected into both exhaust manifolds, mount the oxygen sensor into the pipe immediately after the exhaust manifold. Disconnect the AIR pump tube from the exhaust manifold and plug both ends. Check with local ordinances for the legality of this procedure in your area.

WARNING! Failure to disconnect the AIR pump or locating the oxygen sensor downstream from AIR injection will result in an extremely rich mixture which could cause drivability problems and severe engine damage.

9.6.2 ECU Mounting

The ECU can be mounted inside the passenger compartment (preferable location), or in the engine compartment. If mounted in the engine compartment, follow these guidelines:

- The ECU should be located such that it isn't being directly hit by water or road debris.
- It should also be located such that it isn't extremely close to exhaust manifolds or headers.
- It should be mounted such that it is as far away from spark plug wires, CD ignition boxes, or other "electrically noisy" devices as is reasonable possible.

The ECU comes with mounting hardware and vibration absorbers. Mount the vibration absorbers between the ECU feet and the mounting location. Do not over-tighten the mounting hardware if the ECU is not mounted on a flat surface.

10.0 WIRING

The following overviews how to properly install the wiring harnesses for this system.

10.1 Important Wiring "Do's and Don'ts"

An EFI system depends heavily on being supplied a clean and constant voltage source. The grounds of an electrical system are just as important as the power side.

Avenger ECU's contain multiple processing devices that require clean power and ground sources. The wiring harnesses for them must be installed in such a manner that they are separated from "dirty" power and ground sources.

DO'S

- Install the main power and ground directly to the battery.
- Keep sensor wiring away from high voltage or "noisy/dirty" components and wiring, especially secondary ignition wiring (plug wires), ignition boxes and associated wiring.
- Properly solder and heat shrink any wire connections.
- It is critical that the engine has a proper ground connection to the battery and chassis.

DON'TS

- NEVER run high voltage or "noisy/dirty" wires in parallel (bundle/loom together) with any EFI sensor wiring. If wires need to cross, try to do so at an angle.
- Do not use the electric fan outputs to directly power a fan. They must only trigger a relay.
- Do not use improper crimping tools.
- Don't use things like "t-taps", etc. Use solder and heat shrink.
- It is never recommended to splice/share signal wires (such as TPS, etc) between different electronic control units.

11.0 WIRING HARNESS INSTALLATION

11.1 Main Power/Battery Connection

The AVENGER ECU has a main battery power and ground connector on the right side of the ECU. The bottom position, Terminal "A" is the ground. The upper position, Terminal "B" is the positive terminal. Always use the fused power cable with the proper connectors supplied by Holley only.



Figure 8

12.0 PRIMARY HARNESS INSTALLATION AND SENSORS CONNECTION

These sections review the Main Harness installation and all of the sensor connections that must be completed. The Main Harness is the primary harness that supports all the primary engine sensors, fuel and ignition. There are two main connectors for this harness that plug into the ECU.

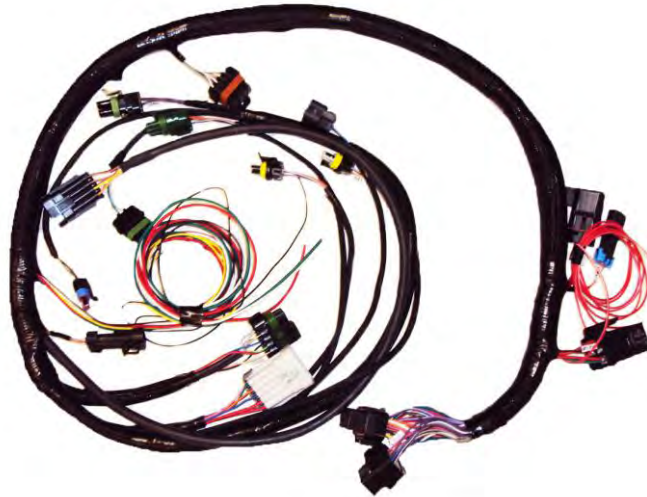

Figure 9

12.1 ECU Connectors

AVENGER ECU – The AVENGER ECU has **two** main connectors:

- **P1A** - The first connector next to the USB connector is the “P1A” connector (34 pin). This connector is primarily an “Input” connector. It contains all the sensor inputs and wide band oxygen sensor control.
- **P1B** - The second connector is the “P1B” connector (26 pin). This connector is the “output” connector. It has 8 injector outputs and outputs for other devices.

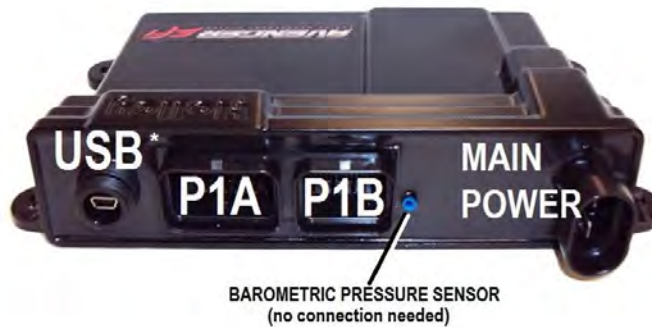

Figure 10

*USB is not used on Avenger EFI

12.2 Harness Routing

If the ECU is mounted in the interior, it will have to be routed through the firewall into the engine compartment. Use a 2” hole saw to create a hole in a desired location if no other point of access is available. A grommet is supplied for a 2” hole to seal this area.

If the ECU is mounted in the engine compartment, the hand-held tuning module cable will have to be routed to the “CAN” connector on the main harness (located near the ECU connector main connector). This will require routing 1” x ½” connector somewhere through the firewall.

Connect the P1A and P1B connectors of the main harness into the ECU.

About 12” from the ECU main connectors is a 40A Relay. This powers the injectors and fuel pump.

12.3 Sensor Connections & Outputs

The following indicates the primary sensors that are required to be connected. Each connector on the main harness is labeled with the sensor name. The name on this label for each sensor is in parenthesis below.

12.3.1 Throttle Position Sensor (TPS)

Connect to the TPS which is located on the throttle body.

12.3.2 Manifold Air Pressure Sensor (MAP)

A 1 Bar MAP sensor is provided with all Holley EFI systems. Connect to the MAP sensor. Make sure that a vacuum line was connected to the MAP sensor in previous steps.

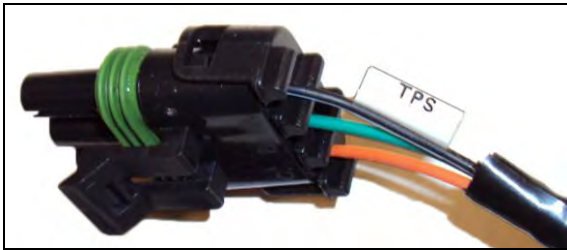

Figure 11 TPS

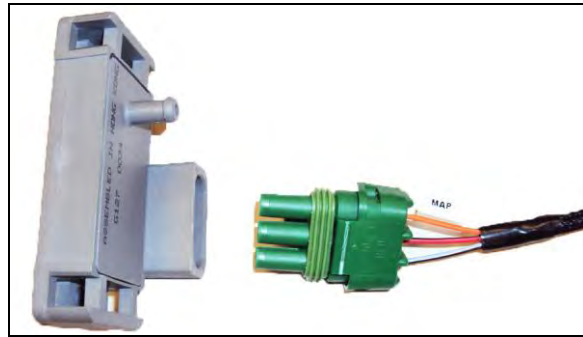

Figure 12 MAP

12.3.3 Coolant Temperature Sensor (CTS)

Connect to the Coolant Temperature sensor which should have been installed in an engine coolant passage.

12.3.4 Manifold Air Temperature Sensor (MAT)

Connect to the Air Temperature Sensor. This is located on the back of the intake plenum.

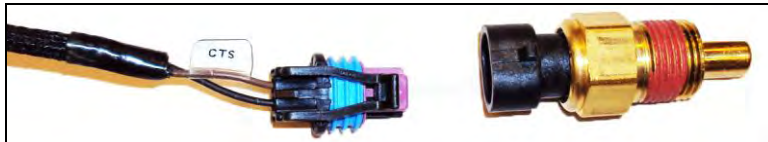

Figure 13 CTS

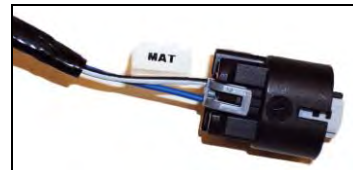

Figure 14

12.3.6 Wide Band Oxygen Sensor (WB02)

Connect to the oxygen sensor connector to the oxygen sensor previously installed. If you need an extension cable, one is available from Holley (P/N 534-199). The Avenger systems are intended to be used with a Bosch wide band oxygen sensor supplied by Holley. Make sure yours is the same as the picture below:

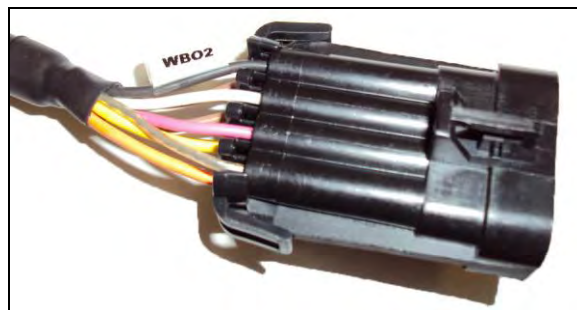

Figure 15 WB02

12.3.7 Fuel Pressure (Fuel)

A fuel pressure transducer connector is pre-installed in the main harness. The system is plug-and-play configured for a Holley 100 PSI pressure transducer (can be purchased under PN 554-102). If these are not connected to a pressure transducer, the Fuel and Oil Pressure will read “LEr” on the hand-held display. This will not cause any issues. Connect to the transducer (if installed).

12.3.8 Oil Pressure (Oil)

An oil pressure transducer connector is pre-installed in the main harness. The system is plug-and-play configured for a Holley 100 PSI pressure transducer (can be purchased under PN 554-102). If these are not connected to a pressure transducer, the Fuel and Oil Pressure will read “LEr” on the hand-held display. This will not cause any issues. Connect to the transducer (if installed).



Figure 16 Fuel



Figure 17 Oil

12.3.9 CANbus – Handheld (CAN)

The handheld controller is used for create of an initial calibration for the system, allows for simple tuning changes to be performed, and is also used to view various information of the EFI system. It should be installed such the handheld controller can be easily used in the passenger compartment. The handheld has two loose wires and one connector with orange wires. Plug the connector into the main wiring harness into the plug marked “CAN”. This plug is located about 8 inches from the ECU connector. The handheld controller also has a white and a black wire. The black wire should be run to a sound vehicle ground. The white wire should be connected to a +12 volt source switched ignition source. The handheld does not have to be powered/installed after the vehicle is up set up and running properly.

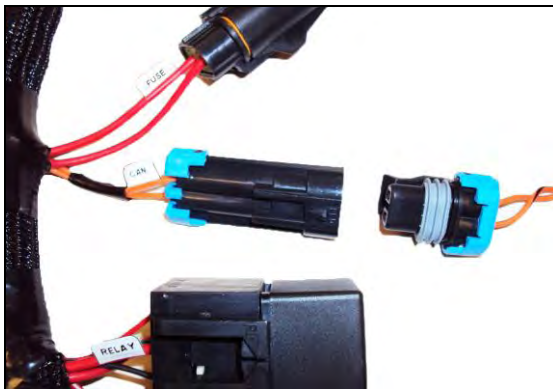

Figure 18 Harness to Handheld



Figure 19 Handheld

12.3.10 Knock Sensor (Knock)

The knock sensor connector is NOT used on Avenger systems.

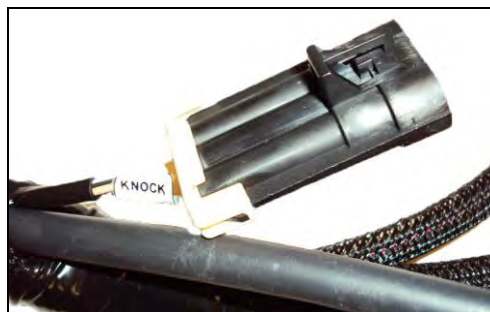

Figure 20 Knock

12.3.11 Ignition (IGN) –

There is a 10 pin connector marked “IGN”. This is to connect to various ignition systems. This is not required for some applications. See section 16.0 below for proper ignition wiring.

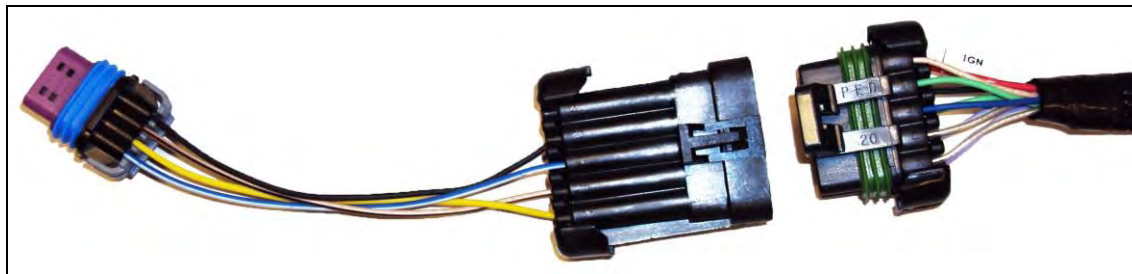

Figure 21 IGN (Shows Adapter for Small Cap Computer Controlled GM HEI Distributor)

13.0 PRIMARY OUTPUTS

13.1 Idle Air Control (IAC)

Connect to the idle air control motor which is installed in the throttle body (Fig 22).

13.2 Fuel Injector Outputs (INJ) and Fuel Injector Harness

Install the fuel injector harness on the fuel injectors. Each injector connector is labeled with the proper cylinder number. Then connect the fuel injector harness to the injector connector on the main harness (marked INJ).



Figure 22 IAC

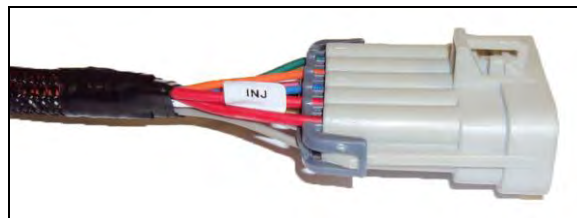

Figure 23 INJ

14.0 LOOSE WIRES

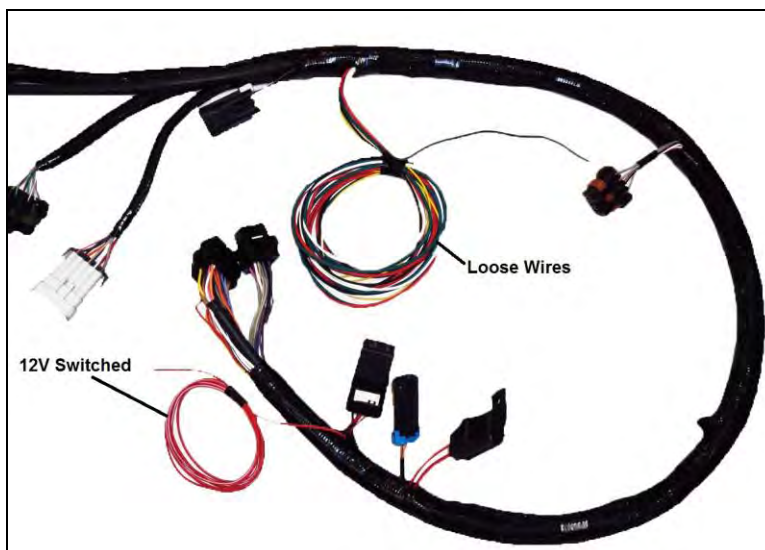

Figure 24

The following loose wires in the main wiring harness should be connected as follows on all systems. All of these wires come out of the harness about 40" from the ECU connectors except for the "12V Switched" wire.

12V Switched – Color = Red/White – Should be connected to a clean +12 volt power source. Power source should only be active when the ignition is on. Make sure source has power when engine is cranking as well (check with voltmeter). Not all sources apply power when the ignition switch is in "cranking" position. This wire is located approximately 7" from the ECU connectors. **Refer to Figure 24.**

12V Battery – Color = Red – Should be connected directly to the battery. This powers the fuel pump and fuel injectors. This wire is protected by a fuse in a sealed fuse holder. The fuse holder is located about 9" from the ECU connector. A fuse is pre-installed (20A).

12V Fuel Pump – Color = Green - Used to directly power a fuel pump (+12 volt). Do not use this wire to power fuel pumps that require over 10-12 Amps. For high current pumps, use this wire to trigger a separate relay and use larger gauge wire to feed the pump - 10 gauge is recommended. The pump that include with Avenger systems draws less than 10 Amps and can be powered directly by this wire.

The fuel pump also requires a ground wire. Run a wire from the negative side of the fuel pump (marked "-" on the Holley pump in this kit). Connect it to a solid chassis/frame ground.



Figure 25

Points Output – Color = White – This wire is NOT used with the Avenger system. Tape up the end or install heat shrink in it.

Chassis Ground – Color = Black – Connect to a chassis ground point that has excellent connectivity with both the engine and the battery.

“Coil –” – Color = Yellow – See section 15.0 below. This is an RPM input wire used for *some* applications.

15.0 IGNITION/ENGINE SPEED INPUT

The most important signal for the ECU is the Engine Speed input. It is critical that this is configured and wired correctly or poor performance will result.

There are 3 engine speed options on the Avenger systems. Each one is wired differently. If these are wired incorrectly, it is easily possible to permanently damage the ECU so pay close attention to proper wiring. These options are described below and wiring diagrams are supplied below the descriptions:

OPTION 1) “Coil –“ engine speed input – Use this if:

- You are using a stock type mechanical advance distributor with a stock inductive ignition coil. Examples of this would be any older style points distributor, a 1974-1981 GM large cap HEI.
- Do NOT use this input if you are using an aftermarket Capacitive Discharge (CD) ignition system such as a MSD, Mallory, or others. The ECU will be damaged if you connect to a capacitive discharge type ignition coil.

NOTE: Using this input, the EFI will NOT control the ignition timing of the engine. The timing will be based on the distributor initial, mechanical, and vacuum advance, just like it did with a carburetor.

OPTION 2) “Tach Out” engine speed input -

- If you are using an aftermarket Capacitive Discharge (CD) ignition system such as a MSD, Mallory, or others, you need to connect to the “Tach Out” connection or wire these systems provide. This is a 12 volt square wave output.

CAUTION! NEVER, NEVER connect any of the EFI wires to the coil on any CD type ignition system. The ECU will be permanently damaged!

NOTE: Using this input, the EFI will NOT control the ignition timing of the engine. The timing will be based on the distributor initial, mechanical, and vacuum advance, just like it did with a carburetor.

OPTION 3) "GM Small Cap HEI" Computer Controlled Distributor –

- Small and Big Block Chevy engines can use a small cap GM HEI computer controlled distributor that was available on factory GM vehicles from the 1980's through mid 1990's. This distributor provides an engine speed signal to the EFI, as well as allowing the EFI to control the ignition timing.

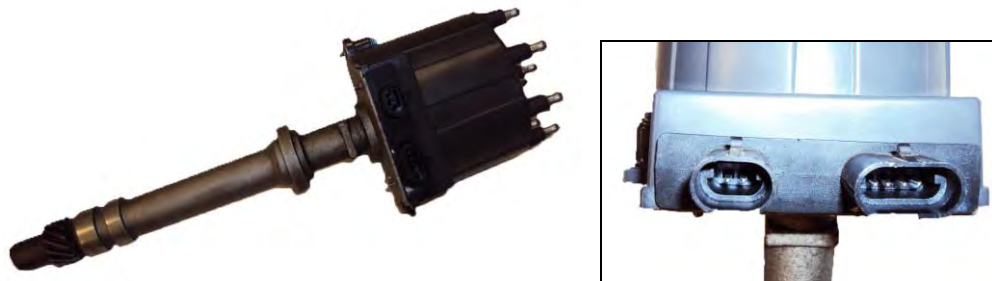

Figure 26 GM Small Cap HEI Distributor and Close Up of Distributor

16.0 IGNITION/ENGINE SPEED INPUT WIRING

OPTION 1 – "Coil –" – Option one uses the "Yellow Wire" for engine speed input. The yellow wire is a loose wire located 40" from the ECU connectors. It is bundled with several other loose wires. The following two diagrams show how to wire to the two most common applications which are:

- 1) Any General Motors engine equipped with a factory large cap HEI distributor equipped with mechanical/vacuum advance (Figure 27).
- 2) Any engine equipped with a factory mechanical advance distributor and separate canister style coil. This would include any points style distributor (Figure 28).

Figure 27 below shows how to connect to a large cap HEI distributor.

HOLLEY EFI TO GM HEI - USING MECHANICAL AND VACUUM ADVANCE 4-PIN MODULE DISTRIBUTOR (ECU "NOT" CONTROLLING IGNITION TIMING)

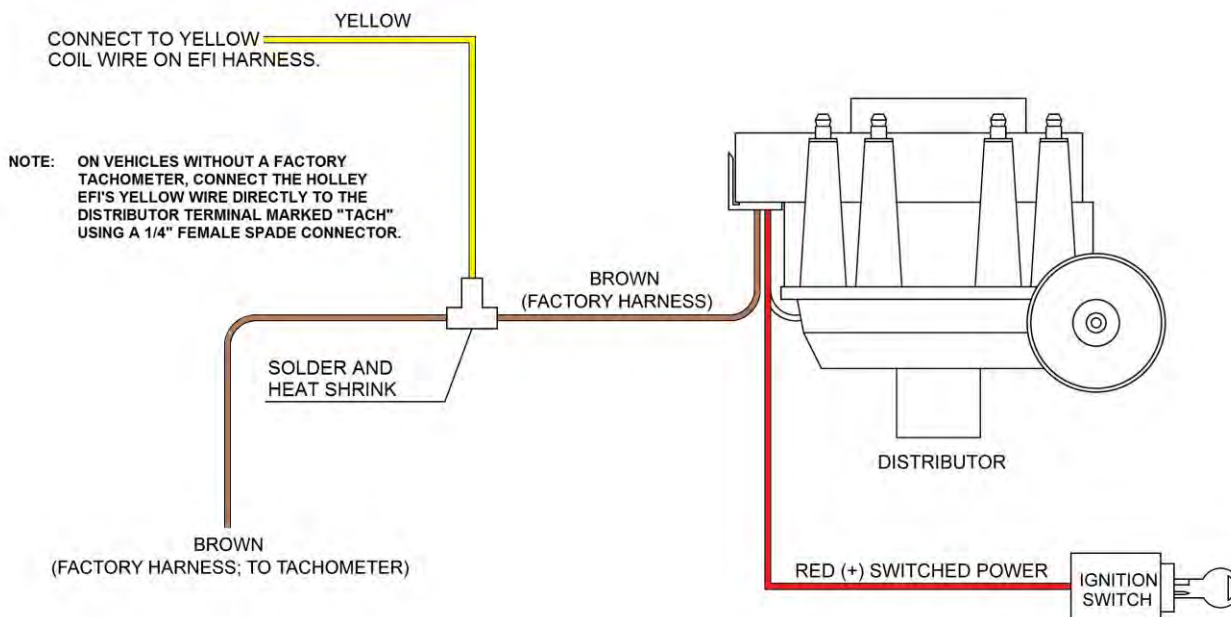

Figure 27

Figure 28 below shows how to connect to a factory style ignition with a canister style coil.

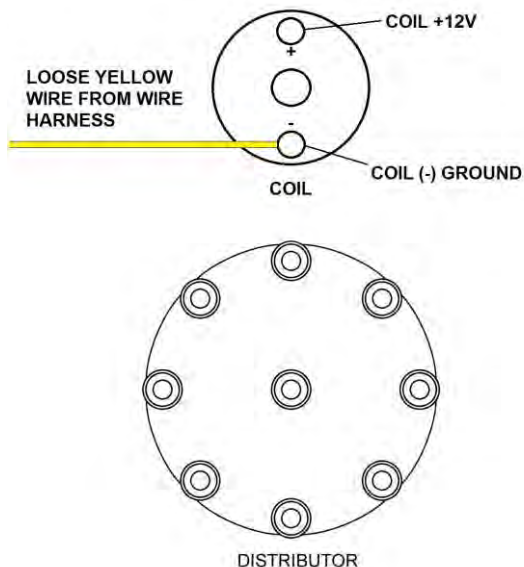

Figure 28

OPTION 2 – “Tach Out” – If using an aftermarket Capacitive Discharge (CD) ignition system, you need to connect to the “Tachometer Output” connection on the ignition box. To do so, you need to install the included ignition adapter that comes with your kit. This adapter will have a single “yellow/black” wire (yellow wire with a black stripe) that you will connect to the tach out on the ignition box. This output usually is typically a spade type connector on the side of the box, or a wire coming out of the box. This adapter looks like this:

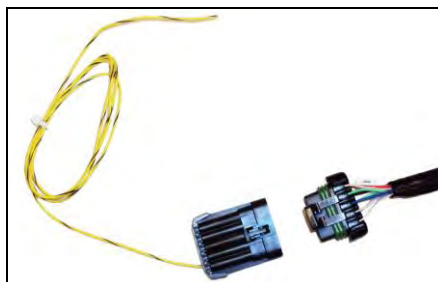

Figure 29

Connect it to the main EFI harness to the connector marked “IGN” (Ignition). Connect the yellow/black wire to the “tach out” connection on your ignition box. If you don’t know what wire this is, contact the tech service department for the ignition system you purchased.



Figure 30

OPTION 3 - "GM Small Cap HEI" Computer Controlled Distributor – An ignition adapter to connect to a computer controlled small cap HEI distributor is included with all Small and Big Block Chevy multi-port Avenger EFI kits. This adapter looks like:

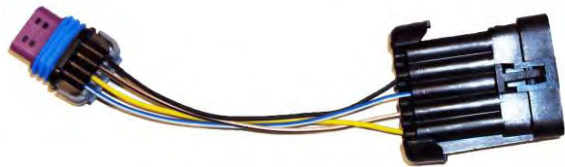

Figure 31

Connect this adapter to the main EFI harness to the connector marked "IGN" (Ignition). Connect the other end to the 4 pin connector on the HEI distributor. You will need to supply the wiring to connect the distributor to the coil.

Figure 32 shows how to wire when NOT using an aftermarket CD box. **Figure 33** Shows how to wire when using an aftermarket CD box.

HOLLEY EFI TO GM HEI IGNITION - USING COMPUTER CONTROLLED DISTRIBUTOR, EXTERNAL COIL (ECU CONTROLLING TIMING)

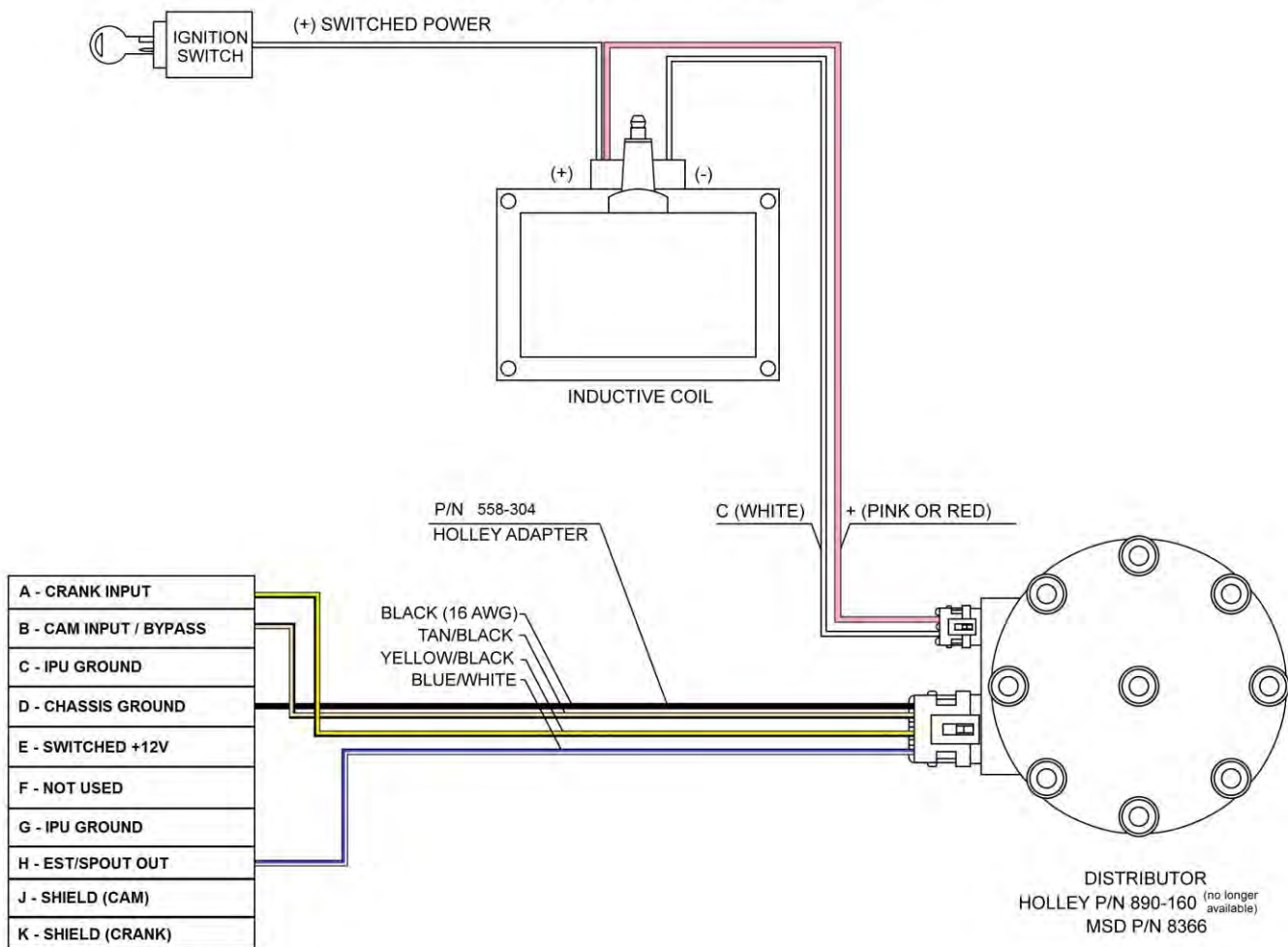

Figure 32

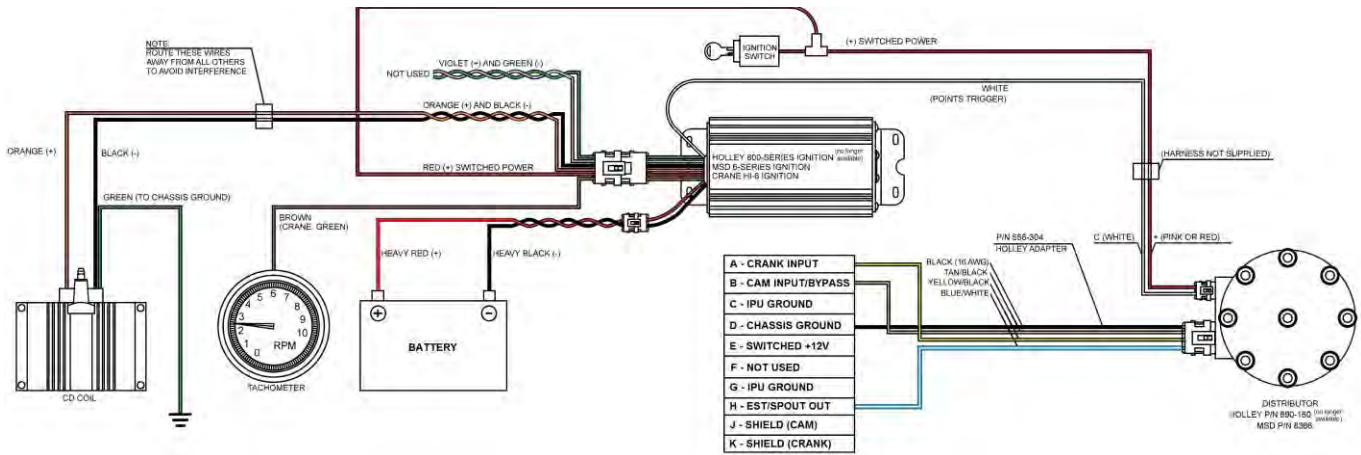

Figure 33

17.0 ADDITIONAL OUTPUTS

There are 3 optional outputs available on the system that can be use for the following features:

- Air Conditioning Shutdown at wide open throttle
- Electric Fan #1 output
- Electric Fan #2 output

These outputs are located in the "Input/Output" connector. This connector is located about 27 inches from the ECU connector and contains 8 pins. 3 of these are used for the features mentioned above. A harness is available to plug into this connector under Holley PN 558-400 that provides a mating plug in connector and additional harness length. If you wish to not purchase this mating harness, but want to use these options, you can remove a single wire from the main harness Input/Output connector and solder an additional length of wire on for the features you wish to use.

The following indicates proper wiring for these features.

A/C Shutdown – This output will provide a +12 volt output a defined throttle position. This output can be used to trigger a relay that deactivates the A/C at higher throttle positions. This may require the installation of a 5 pole relay in the existing A/C wiring. This wire is located in pin E of the 8 pin Input/Output connector and is Grey with a Yellow stripe.

Electric Fan #1 output – This output will provide a ground output to trigger a relay used for a cooling fan. This output should never be directly connected to a fan, but the relay that powers the fan. It should be connected to the ground trigger of the relay. This wire is located in pin G of the 8 pin Input/Output connector and is Grey with a Black stripe.

Electric Fan #2 output – This output will provide a ground output to trigger a relay used for a cooling fan. This output should never be directly connected to a fan, but the relay that powers the fan. It should be connected to the ground trigger of the relay. This wire is located in pin G of the 8 pin Input/Output connector and is Grey with a Green stripe.

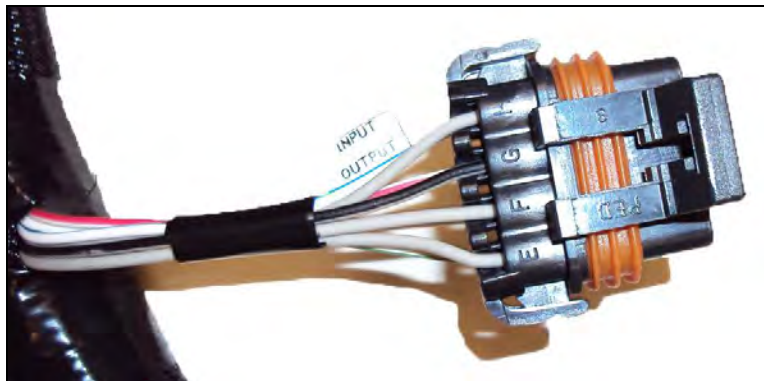

Figure 34

APPENDIX 1.0

Pinout

The following shows pins that are used on Avenger systems. Pins that are not used on Avenger systems, but may have wires populated in the harness, are denoted with an asterisk (*).

P1A Connector

Pin	Function
A1	Coil – Input
A2	Fuel Pump Out (+12v) (10A Max)
A3	*
A4	*
A5	TPS Input
A6	*
A7	WB1 COMPR2
A8	WB1 Shield
A9	WB HTR -
A10	Switched +12v Input
A11	Manifold Air Temp Input
A12	*
A13	*
A14	Cam/Crank Ground
A15	Gauge Digital Output
A16	WB1 COMPR1
A17	WB1 VS-/IP+
A18	Sensor Ground
A19	Engine Coolant Temp Input
A20	Oil Pressure Input
A21	*
A22	Cam Sync Input / Ignition Bypass Output
A23	Map Sensor Input
A24	CAN Lo
A25	WB1 VS+
A26	Sensor +5v
A27	NOT USED
A28	EST/Spout Output
A29	*
A30	Crank Speed Input
A31	Fuel Pressure Input
A32	CAN Hi
A33	WB1 IP+
A34	WB HTR +

P1B Connector

Pin	Function
B1	IAC A Lo
B2	IAC A Hi
B3	Fan #2 Output (ground)
B4	Injector F Output
B5	Injector G Output
B6	Injector H Output
B7	Injector E Output
B8	IAC B Lo
B9	IAC B Hi
B10	Fan #1 Output (ground)
B11	*
B12	A/C Shutdown (+12v)
B13	Injector D Output
B14	*
B15	*
B16	*
B17	*
B18	*
B19	Injector A Output
B20	EST 12V Output
B21	*
B22	*
B23	*
B24	*
B25	Injector C Output
B26	Injector B Output

Holley Performance Products
1801 Russellville Road
Bowling Green, KY 42101

Technical Service: 1-270-781-9741
Fax: 1-270-781-9772

For online help, please refer to the Technical Information section of our website: www.holley.com

199R10554 wf
Date: 5-10-11

**271R973A
HOLLEY EFI
STEALTHRAM & TPI
(WIRING HARNESS ONLY SALES P/N 558-101)**

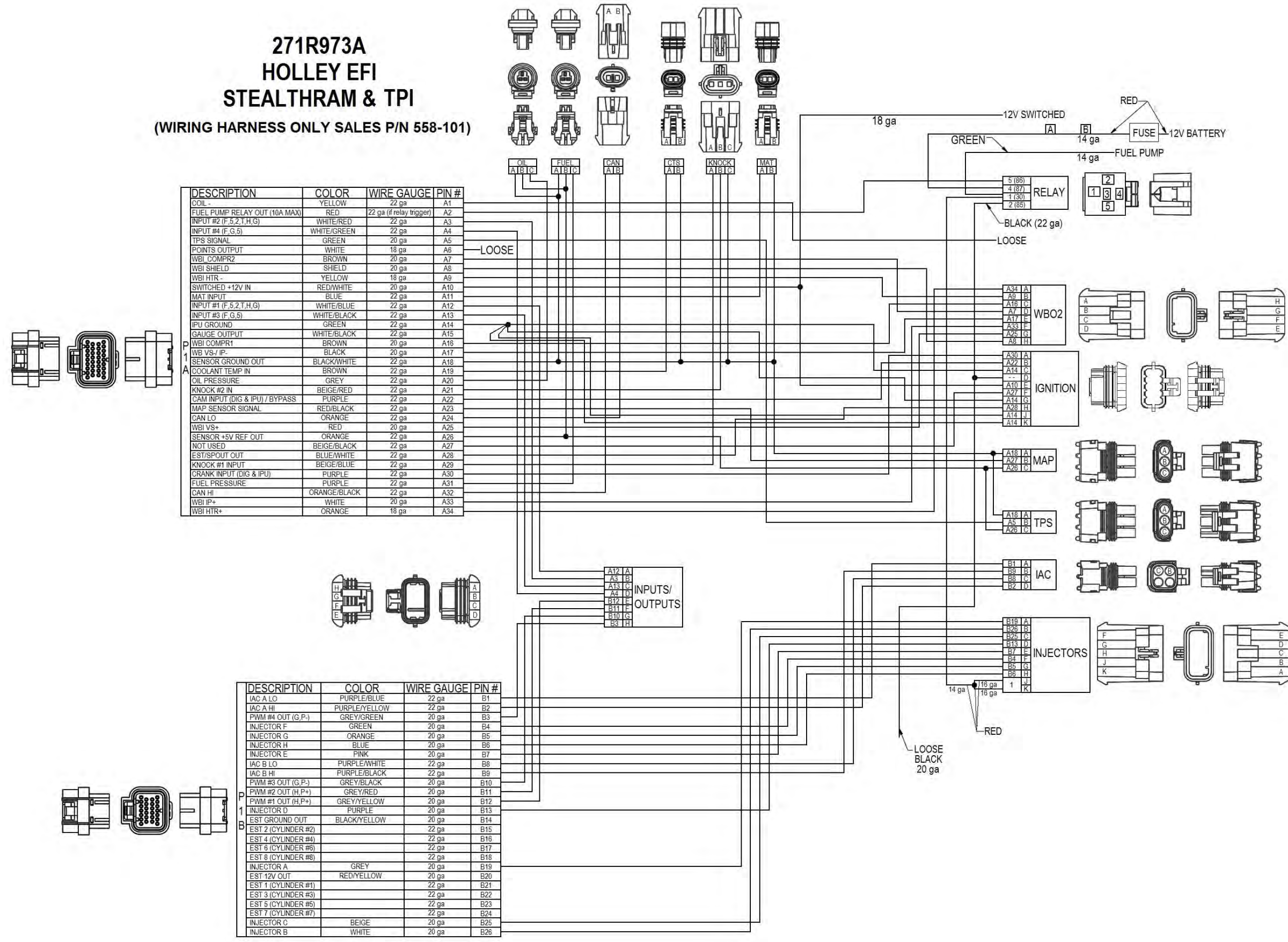

DESCRIPTION	COLOR	WIRE GAUGE	PIN #
COIL -	YELLOW	22 ga	A1
FUEL PUMP RELAY OUT (10A MAX)	RED	22 ga (if relay trigger)	A2
INPUT #2 (F, 5, 2, T, H, G)	WHITE/RED	22 ga	A3
INPUT #4 (F, G, 5)	WHITE/GREEN	22 ga	A4
TPS SIGNAL	GREEN	20 ga	A5
POINTS OUTPUT	WHITE	18 ga	A6
WBI COMPR2	BROWN	20 ga	A7
WBI SHIELD	SHIELD	20 ga	A8
WBI HTR -	YELLOW	18 ga	A9
SWITCHED +12V IN	RED/WHITE	20 ga	A10
MAT INPUT	BLUE	22 ga	A11
INPUT #1 (F, 5, 2, T, H, G)	WHITE/BLUE	22 ga	A12
INPUT #3 (F, G, 5)	WHITE/BLACK	22 ga	A13
IPU GROUND	GREEN	22 ga	A14
GAUGE OUTPUT	WHITE/BLACK	22 ga	A15
WBI COMPR1	BROWN	20 ga	A16
WB VS- / IP-	BLACK	20 ga	A17
SENSOR GROUND OUT	BLACK/WHITE	22 ga	A18
COOLANT TEMP IN	BROWN	22 ga	A19
OIL PRESSURE	GREY	22 ga	A20
KNOCK #2 IN	BEIGE/RED	22 ga	A21
CAM INPUT (DIG & IPU) / BYPASS	PURPLE	22 ga	A22
MAP SENSOR SIGNAL	RED/BLACK	22 ga	A23
CAN LO	ORANGE	22 ga	A24
WBI VS+	RED	20 ga	A25
SENSOR +5V REF OUT	ORANGE	22 ga	A26
NOT USED	BEIGE/BLACK	22 ga	A27
EST/SPOUT OUT	BLUE/WHITE	22 ga	A28
KNOCK #1 INPUT	BEIGE/BLUE	22 ga	A29
CRANK INPUT (DIG & IPU)	PURPLE	22 ga	A30
FUEL PRESSURE	PURPLE	22 ga	A31
CAN HI	ORANGE/BLACK	22 ga	A32
WBI IP+	WHITE	20 ga	A33
WBI HTR+	ORANGE	18 ga	A34

DESCRIPTION	COLOR	WIRE GAUGE	PIN #
IAC A LO	PURPLE/BLUE	22 ga	B1
IAC A HI	PURPLE/YELLOW	22 ga	B2
PWM #4 OUT (G, P-)	GREY/GREEN	20 ga	B3
INJECTOR F	GREEN	20 ga	B4
INJECTOR G	ORANGE	20 ga	B5
INJECTOR H	BLUE	20 ga	B6
INJECTOR E	PINK	20 ga	B7
IAC B LO	PURPLE/WHITE	22 ga	B8
IAC B HI	PURPLE/BLACK	22 ga	B9
PWM #3 OUT (G, P+)	GREY/BLACK	20 ga	B10
PWM #2 OUT (H, P+)	GREY/RED	20 ga	B11
PWM #1 OUT (H, P+)	GREY/YELLOW	20 ga	B12
INJECTOR D	PURPLE	20 ga	B13
EST GROUND OUT	BLACK/YELLOW	20 ga	B14
EST 2 (CYLINDER #2)		22 ga	B15
EST 4 (CYLINDER #4)		22 ga	B16
EST 6 (CYLINDER #6)		22 ga	B17
EST 8 (CYLINDER #8)		22 ga	B18
INJECTOR A	GREY	20 ga	B19
EST 12V OUT	RED/YELLOW	20 ga	B20
EST 1 (CYLINDER #1)		22 ga	B21
EST 3 (CYLINDER #3)		22 ga	B22
EST 5 (CYLINDER #5)		22 ga	B23
EST 7 (CYLINDER #7)		22 ga	B24
INJECTOR C	BEIGE	20 ga	B25
INJECTOR B	WHITE	20 ga	B26

271R973A HOLLEY EFI STEALTHRAM & TPI

(WIRING HARNESS ONLY SALES P/N 558-101)

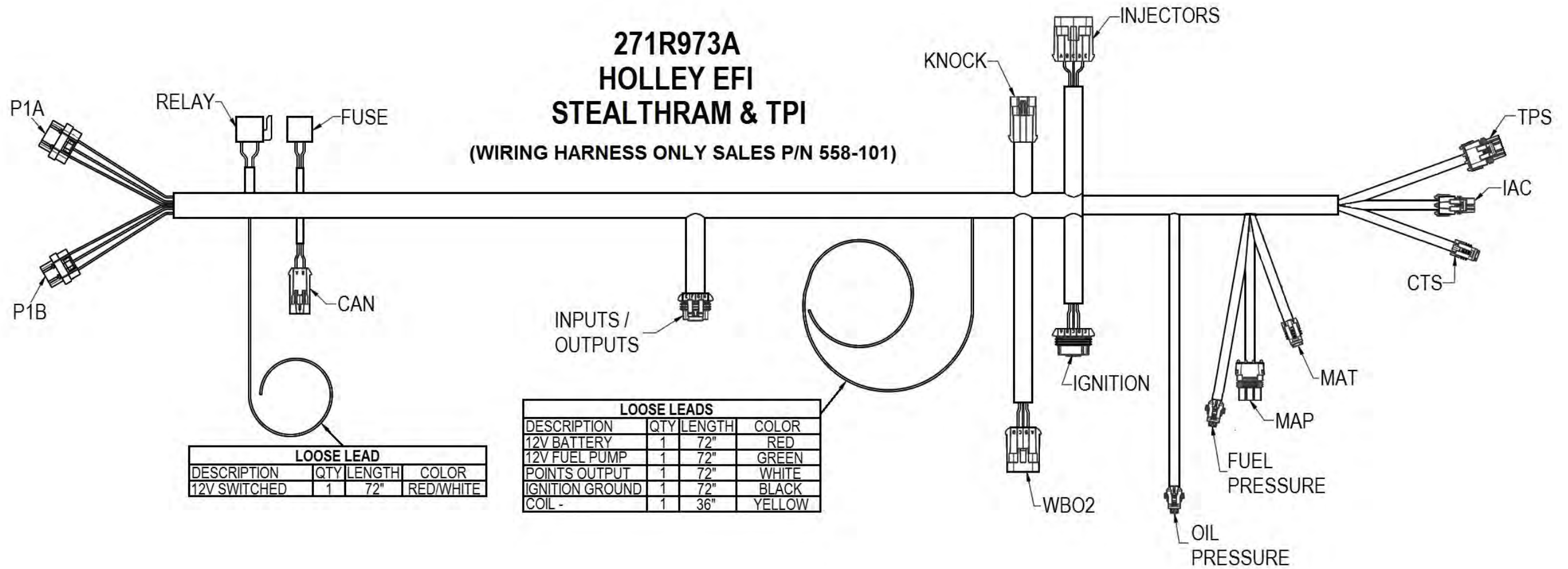

LOOSE LEAD			
DESCRIPTION	QTY	LENGTH	COLOR
12V SWITCHED	1	72"	RED/WHITE

LOOSE LEADS			
DESCRIPTION	QTY	LENGTH	COLOR
12V BATTERY	1	72"	RED
12V FUEL PUMP	1	72"	GREEN
POINTS OUTPUT	1	72"	WHITE
IGNITION GROUND	1	72"	BLACK
COIL -	1	36"	YELLOW