



Crank Trigger Systems for Small and Big Block Chevy PN's 556-110 and 556-111 Installation and Adjustment Instructions

1.0 INTRODUCTION:

Congratulations on your purchase of a Holley Crank Trigger System! Holley Performance Products cannot and will not be responsible for any alleged or actual engine or other damage, or other conditions resulting from misapplication of the products described herein. However, it is our intent to provide the best possible products for our customer; products that perform properly and satisfy your expectations. Should you need information or parts assistance, please contact our Technical Service Department at 1-270-781-9741, Monday through Friday, 8 a.m. to 5:00 p.m. Central Time; please have the part number of the product you purchased when you call.

These systems are designed to provide an engine speed signal specifically to Holley EFI systems only. The 58 tooth wheel will provide a very accurate crankshaft speed signal to the ECU. These systems come with the hardware, sensor, and wiring necessary for installation.

NOTE: It will be necessary to move any engine accessories about 1/8" to accommodate the spacing the trigger wheel adds.

WARNING! These instructions must be read and fully understood before beginning installation. Failure to follow these instructions may result in poor performance, vehicle damage, personal injury or death. If these instructions are not fully understood, installation should not be attempted.

2.0 APPLICATIONS:

PART NUMBER	APPLICATION
556-110	Small Block Chevy crank trigger system. 8.5" diameter wheel
556-111	Big Block Chevy crank trigger system. 8.5" diameter wheel. Mark IV & Gen 6 engines

NOTE: Will not fit a gen 6 BBC with a 1.60" Balancer locating pilot (OEM truck applications).

NOTE: Mounting the 60-2 crank trigger wheel will space the lower pulley out 1/8". This requires that all other pulleys be moved out 1/8" as well for proper alignment. A spacer for the water pump is included in SBC and BBC kits. Other items will need to be moved out 1/8"

NOTE: Installation on a SBC/BBC likely requires the removal of some material off of the lower crankshaft pulley. This does NOT require precision machining, but does require (at a minimum) the use of a metal grinder.

3.0 PARTS IDENTIFICATION: Photographs shown are of a Small Block Chevrolet Kit. Your kit may vary.



Crank Trigger Wheel



Block Bracket (SB shown)



Block Bracket Mounting Hardware and Spacers



Sensor Mounting Bracket



**Sensor Mounting
Bracket Hardware**



Centering Adapter



Crank Sensor



Crank Sensor Hardware



Harness



Spacer for Pump



Sensor Shims

4.0 MATERIALS REQUIRED FOR INSTALLATION:

- Standard Socket Set with Driver
- Allen Wrench Set
- Timing Light
- Feeler Gauge Set
- Metal Grinder
- Components to space alternator, PS pump out 1/8"

5.0 INSTALLATION OF 60-2 CRANK TRIGGER WHEEL:

The "60-2" alludes to the fact that crank trigger wheel has 58 teeth with "2 missing". This is also known as a "58x" wheel.

1. Rotate the engine to #1 TDC.
2. Remove any pulleys that are on mounted to the harmonic balancer.
3. Check the surface to which the crank trigger wheel will be mounted to ensure that it is smooth and free of any excess dirt or oil. Clean the surface of the balancer, if necessary.
4. There is an aluminum centering adapter included with the SBC/BBC mounting kits (shown in the parts identification above). It locates in the harmonic balancer. Install it, then slide the crank trigger wheel over it.
5. Determine which side of the engine the sensor will be mounted on. The sensor bracket can be flipped to use on either side of a SBC or BBC engine. With the engine at TDC on #1 cylinder, the sensor will be positioned such that it is lined up with the 11th tooth "after the missing teeth" on the crank trigger wheel (the 11th tooth is the tooth after the gap in the direction that the engine rotates). If this is off, it can be adjusted within the software, but this is the intended location. It is advised not to install it on less than the 9th tooth. If the 11th tooth is not possible, use the 12-20th tooth. Install the crank trigger wheel and align the bolt holes on it such that the sensor will be near this position.

Most all engines rotate clockwise, except for Honda engines which rotate counter-clockwise. If you are confused about which tooth this means, put the trigger wheel on the engine and rotate just the trigger wheel (leave the engine at TDC on #1) in the direction the engine rotates. Rotate it until the missing teeth/gap line up to where the sensor will be mounted, then continue turning it and count 11 teeth. Take a marker and mark this tooth. It will be the tooth you need to align with the sensor.

6. Install some bolts to hold the trigger wheel in position on the engine for the time being.

6.0 INSTALLATION OF ENGINE BLOCK BRACKET:

1. Install the block bracket using the two 1-3/4" long counter-sunk socket head cap screws and 1/2" spacers. The spacers should put the pickup at the correct location. If it does not, washers of the proper size and thickness must be purchased to shim the bracket as needed. That alignment will be checked in Section 7.0, step 3 below.

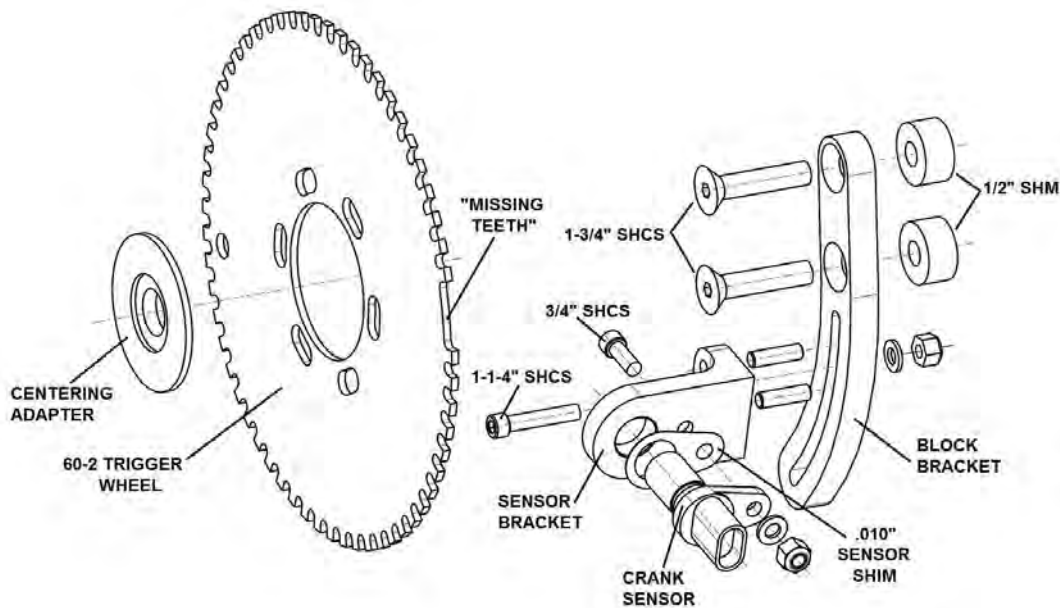

Figure 1

7.0 INSTALLATION OF ADJUSTABLE SENSOR AND SENSOR BRACKET:

1. The crank sensor must have the proper air gap (.020" - .035"). It may be necessary to add sensor shims (included in the kit) to set the proper air gap. It is advised to make check the gap in 3 places around the wheel to make sure there is not excessive run out for any reason (shouldn't be more than .005"). Note that some engines have a lot of crankshaft deflection (high RPM and/or large cubic inch) and should set the gap to .030-.040". If the sensor is contacted by the wheel, it may be damaged. If you have an engine with more than .030-.040" of flex, it is advised to use a magnetic pickup type crank trigger, as these are not as sensitive to gap as a hall effect pickup.
2. Using the 3/4" long socket head cap screw, washer and locknut, install the crank sensor to the sensor bracket using one .010" shim. Note the proper orientation of the sensor and sensor bracket in **Figure 1**.
3. Using the 1-1/4" long socket head cap screw, washer and lock-nut, install the sensor and bracket assembly to the block bracket as shown in **Figure 1**. The dowel pins will help align the sensor bracket. It is possible that the sensor will interfere with the trigger wheel. If it does, add more .010" shims as needed to obtain a .020"-.035" air gap.

Also verify that the sensor is centered longitudinally/axially on the wheel. If it is off more than .050" *at most*, the block bracket must be re-shimmed appropriately. If you can "see" visually that it is off, it is off too much. **It should "visually look perfect"**.

When doing final installation, make sure that the sensor is aligned to the 11th tooth after the air gap, with the engine at TDC on #1. Tighten the sensor and mounting bracket hardware when complete.

8.0 PULLEY INSTALLATION:

1. Reinstall the lower crank pulley. The lower pulley will likely require a small amount of material to be removed off of its "centering lip". This can be done on a lathe or it can be done with a typical 4" disk grinder. This lip can not be more than .075". **See Figure 2.**
2. Bolt up the lower pulley. Torque to the proper specifications. The use of Loctite or lock-washers on the 3 pulley bolts is highly recommended. Make sure the trigger wheel is still in the intended alignment position with the crank sensor.



Figure 2

9.0 SPACING OTHER DRIVE ACCESSORIES

Any belt driven items, driven off the crankshaft pulley should be spaced out to maintain proper belt alignment. This kit includes a 1/8" spacer for belt driven water pumps. Other accessories such as alternators, power steering pumps, must have their brackets shimmed or modified for proper alignment.

10.0 INSTALLATIONS REQUIRING CUSTOM BRACKETS

The following are key items when making custom brackets to mount the crank sensor and trigger wheels:

- Make sure the crank sensor is rigidly supported. The bracket should not flex. Also make sure the "round head" of the sensor is contained within the bracket. It should fit snugly in the mount.
- Make sure the trigger wheel is concentric as mounted. Run-out will cause the wheel to contact and damage the sensor, or force the need to run excessive air gap. Run-out of the sensor to wheel should not exceed .005".

11.0 WIRING

11.1 Cam Signal/Sync

Note that a cam signal/sync is NOT required to properly run a Holley EFI system, unless you are running a "coil on plug" application (one coil for each cylinder). A cam sync signal is required to run sequentially fired fuel injection. See the PC software instructions for proper setup and installation of the cam sync sensor.

11.2 Crank/Cam Sensor Harness Installation

- **Cam/Crank Sensor Harness** – The cam/crank sensor harness is a fully terminated ignition adapter that connects directly to the Holley, hall effect crank sensor supplied in the kit. It also includes a terminated cam sync connector. This connector plugs into the GM sync pulse distributor used on certain 1990's big block vehicles, AC Delco PN 213-350. This distributor was reproduced and is sold by EFI Connection (www.eficonnection.com) for a very reasonable price. This distributor utilizes a hall-effect cam sync pickup. This distributor, which can be used on Small or Big Block Chevy standard deck height engines, serves the purpose as an oil pump drive and cam sync signal. It is very low profile. If a different cam sync input is used, the proper connector must be installed on this harness.

If you are using a different cam sync sensor, it must be wired and configured properly. Contact Holley tech service, or your EFI dealer if you have questions. Don't guess.

The following diagram shows the crank/cam pickup harness that is included. The 10 pin metripak connector plugs directly into the main harness "ignition connector". The crank sensor plug connects directly to the Holley crank sensor. The cam sensor, as mentioned above is for a GM cam sync distributor. If you are using a different cam sensor, you must install the proper connector on it. Use the diagram below (Figure 3) for proper wiring of the cam sensor.

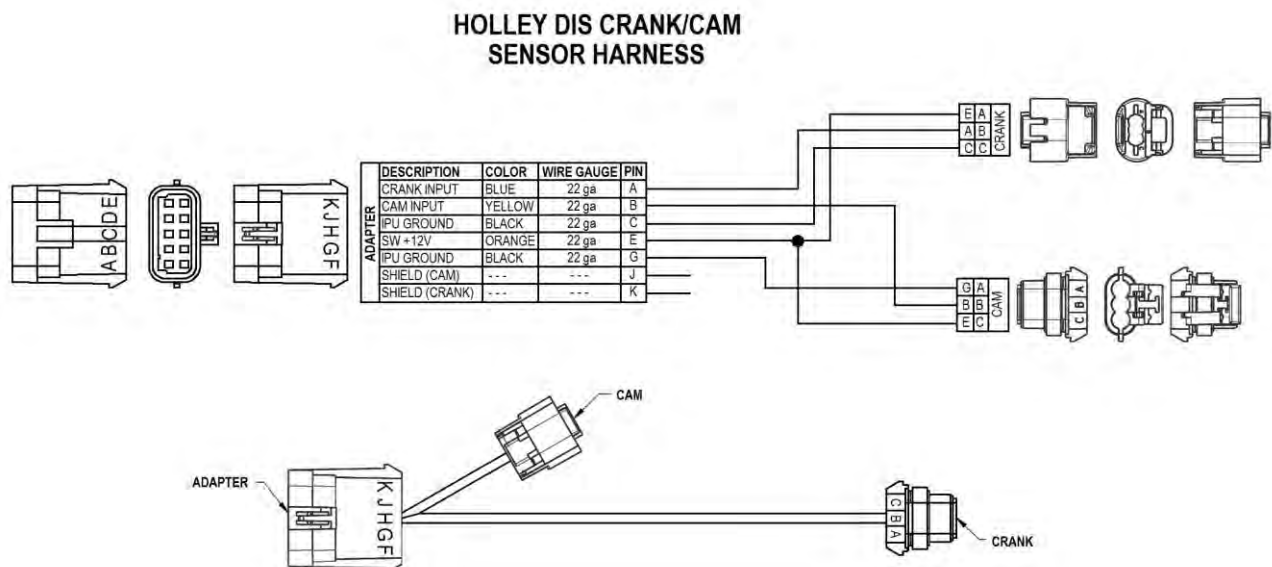

Figure 3

12.0 Software Setup

The following must be properly set up in the software to run this crank trigger wheel.

In the System Parameter ICF, select "Ignition Parameters" tab and look at the "Ignition Type" dropdown. Set it to "CUSTOM". Select the "Configure" tab. Set the following parameters as follows:

- Type = 60-2
- Timing Offset = Start at 0 and adjust as needed.
- TDC Tooth Number = Set to whatever tooth lines up with the sensor with the engine at TDC. 11 was recommended above
- Sensor Type = Select Digital Falling

Under the "Cam Sensor" set it to "Not Used" if no cam sensor is being used or "Single Pulse" if a single pulse cam sync is used. Set the "Sensor Type" per the instructions in the PC Software.

For the "Output Setup" consult the PC software instructions to properly set for your type.

13.0 Initial Startup

WARNING! Do not attempt to change the position of the pickup to adjust the ignition timing while the engine is running. Always shut the engine off while making any adjustments to the location of the pickup. Failure to shut the engine off during adjustment may result in vehicle damage, serious injury, or death.

1. Once everything is installed properly, you need to verify the timing. The following is highly recommended. Disconnect the fuel injector connector harness (so no fuel is injected).
 - 1) Set the cranking timing parameter to 0 (zero) in the Ignition Parameters.
 - 2) Connect a timing light to cylinder #1.
 - 3) Crank the engine, the timing should read "0". If it varies by less than 20 degrees, you can adjust the "Timing Offset" parameter in the Ignition Type setting. (make sure you cycle the ignition power after making this change). If it is more than 20, you need to move the crank sensor or trigger wheel position. Move the sensor itself counter-clockwise if you need to advance the timing. Move it clockwise to retard the timing. In extreme case the wheel can be moved to a different slot position.
2. If everything checks ok in number, re-connect the fuel injectors, set the cranking timing back to the desired setting (15 typically) and start the engine. It should start and run. Check the timing at idle and 3000 RPM or so. It should match the commanded timing. If it is off (shouldn't be off more than a few degrees), adjust the timing offset value to fully sync.
3. Installation and setup should be complete.

**Holley Technical Support
1801 Russellville Road
Bowling Green, KY 42101
270-781-9741
www.holley.com**

**199R10562
Date: 2-7-11**