



HURST ROLL CONTROL INSTALLATION INSTRUCTIONS

5671521

















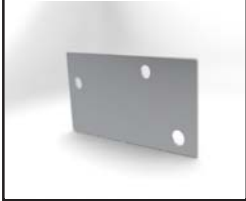



2005-2009 Mustang (V8)
©2011 by Hurst Performance

Thank you for purchasing the Hurst Roll Control system which features an advanced design high quality stainless steel valve assembly for resistance to corrosion, greater durability, reliability, and more precise positive action. In the event that this Hurst Roll/Control should require service, a rebuilt kit is available from your local Hurst performance dealer (Part #5671500)

WARNING: The Hurst Roll Control is designed primarily for high performance race cars to momentarily (maximum of 60 seconds) keep the front brakes engaged while staging for a drag race. It will not safely function as a long term brake holding device. It should never be used as a temporary brake holding device in place of a parking brake or of a driver depressing the brake pedal. The Hurst Roll Control is recommended for use during closed track events and competitive driving venues **ONLY!**

IMPORTANT: Carefully read and fully understand these instructions before installing the Hurst Roll Control. It is important to note that these instructions contain certain cautions and warnings that must be observed in order to reduce the risk of improper installation that could render the vehicle unsafe and result in possible serious bodily injury. If you are not qualified or experienced at performing this type of installation, we strongly recommend that you have the Hurst Roll Control installed by a qualified and certified automotive mechanic.

INSTALLATION NOTES: Any job will be easier and the results more satisfactory if cleanliness is observed. This is especially important when working on the brake system. Do not allow dirt or foreign matter to contaminate the system. This Hurst Roll Control solenoid valve is installed in the front brake system for momentary (maximum of 60 seconds) holding. The solenoid valve will not interfere with normal brake operation when properly installed and operated in accordance with directions provided. Allow vehicle to cool before beginning installation.

PARTS				
S.Steel Brake Line To Master Cylinder 	S.Steel Brake Line To Front Brake Line 	1/8 NPT plug (2) 	S.Steel Adapter (2) 	Solenoid Valve 
1/4-20 Nut (2) 	S.Steel Bracket 	1/4" Flat Washer (2) 	1/4" Lock Washer (2) 	Female Terminal (4) 
1/4-20 Nut (2) 	Lit Momentary Switch 	Rocker Switch 	18 ga. Wire 	Convulced Cover 
Scotchlok™ Conctr. 	Male terminals (2) 	Butt Connectors (3) 	4A Fuse 	5/16" Connectors (3) 



BRAKE LINE INSTALLATION

STEP 1. Identify the mounting location of solenoid and the Master Cylinder front brake line within the engine compartment.

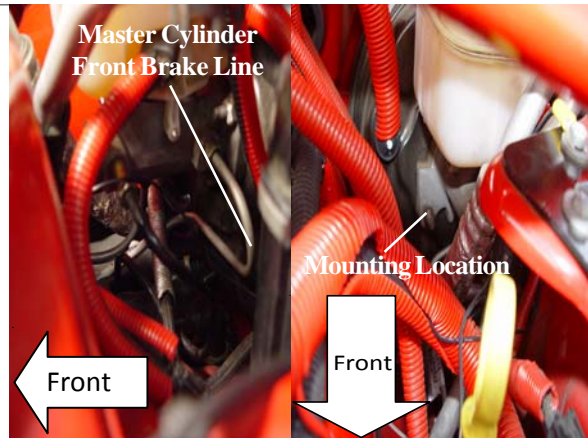

STEP 2. Attach mounting bracket to solenoid as shown in step 2 and 3.

Add a few drops of Loctite® (red) to bolt threads. Place one 1/4-20 bolt, 1/4" flat washer, 1/4" lockwasher, and 1/4-20 nut on each hole and fully tighten to 20Nm (15 ft-lbs).

TOOLS: 7/16" Wrench, 7/16" Socket, Ratchet



STEP 3. Tighten the provided adapters and plugs to solenoid as shown.

TOOLS: 16mm Wrench, 11mm Wrench

NOTE: Use Teflon® tape to ensure a leak-proof seal.

CAUTION: Using an excessive amount of thread sealer can contaminate the solenoid valve or brake system. Use tape sparingly.

If solenoid body loosens while tightening adapters/plugs. First, make sure ports are correctly aligned and then use a 9/16" socket to re-tighten top solenoid nut.

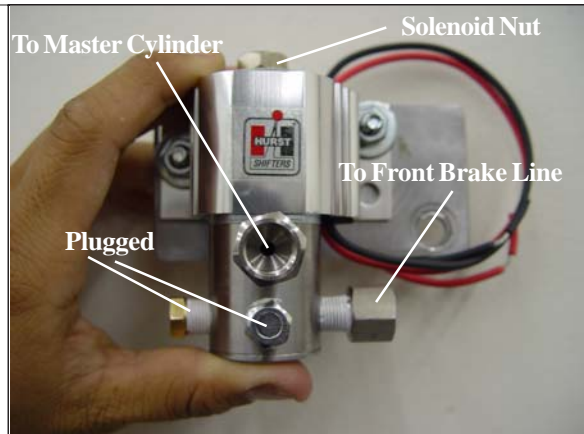

STEP 4. Ensure that the new brake line routing is understood prior to installation. However, DO NOT attach lines to solenoid at this time.

NOTE: Using Teflon® tape on flare fitting threads is generally not recommended. However, if used do not cover any portion of line opening with tape.

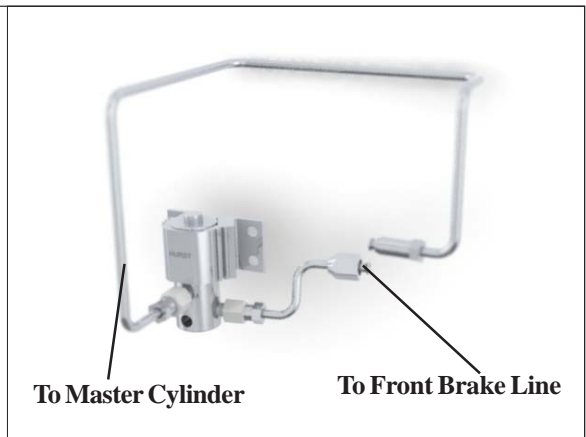

STEP 5. Remove left Master Cylinder nut from Master Cylinder.

TOOLS: 13mm Socket, Ratchet, Extension



STEP 6. Add clean rags under Master Cylinder in order to keep fluid from spilling on vehicle. Unscrew front brake line (Right- closest to driver). Remove front brake line from brake line clip, located on the side of the strut tower.

TOOLS: 13mm Wrench, Clean rags

NOTE: Avoid spilling brake fluid, especially on painted and/or plastic surfaces. Remove any and all excess brake fluid immediately with a clean rag.

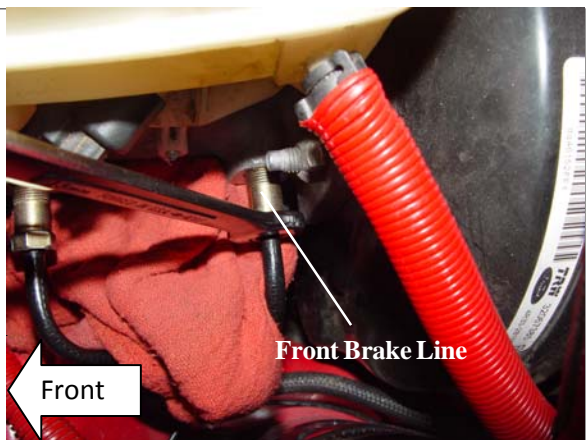

STEP 7. Move flex line from under Master Cylinder front brake line so it won't prevent the Master Cylinder front brake line from screwing into the Hurst brake line. Unscrewing Master Cylinder rear brake line might be required to move flex line.

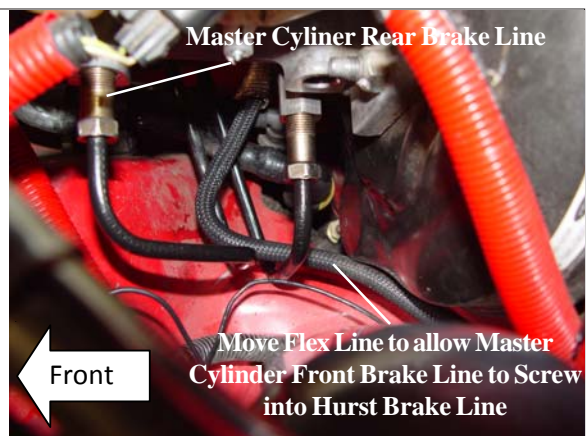

STEP 8. Recommended Installation Method: Thread the Hurst Roll Control brake line into the OEM front brake line, however do not completely tighten fitting at this time to allow for minor adjustments. Thread the Hurst Roll Control brake line into the adapter, finger tight. Push OEM brake line down to allow mounting bracket hole installation onto the Master Cylinder stud. (Slight adjustment (bending/flexing) of lines may be required for proper alignment). Once line is aligned, tighten all flare fittings. **DO NOT OVER TIGHTEN AS THIS WILL CAUSE LEAKS.**

TOOLS: 13mm Wrench (Brake Line nut)
16mm Wrench (Adapter)

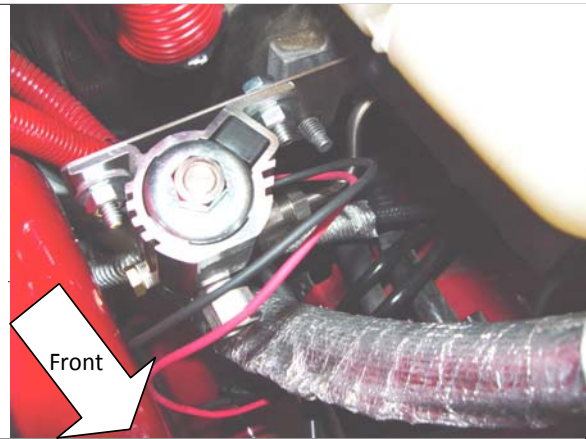

STEP 9. Thread nut back onto master Cylinder stud, tighten Master Cylinder nut to 25Nm (18ft.-lbs).

TOOLS: 13mm Socket, Ratchet, Extension



STEP 10. Recommended Installation Method: Thread the Hurst Roll Control brake line into the Master Cylinder, however do not completely tighten fitting at this time to allow for minor adjustments. Thread Hurst Roll Control brake line into the adapter, finger tight. (Slight adjustment (bending/flexing) of lines may be required for proper alignment). Once line is aligned, tighten all flare fittings. **DO NOT OVER TIGHTEN AS THIS WILL CAUSE LEAKS.**

TOOLS: 13mm Wrench (Brake Line nut)
16mm Wrench (Adapter)

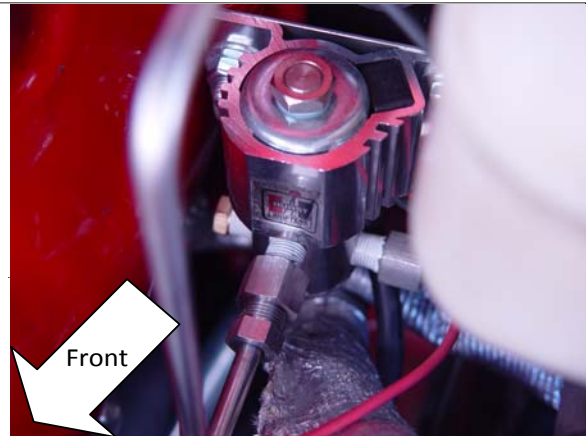

STEP 11. BEFORE OPERATING VEHICLE:

- Bleed **ALL** (back, then front on both sides) brakes by following manufacturer's service manual guidelines (front brakes will usually have the most air).
- Make sure all fittings are fully secured.
- Verify no leaks are present, **THERE SHOULD BE NO LEAKAGE.** The brake pedal should be firm with a solid feel. If brake pedal slowly compresses to the floor, there is a brake fluid leak and/or air in system. Check and re-bleed if necessary. Do not operate vehicle if leaks and/or air in the lines is present no matter how minor.

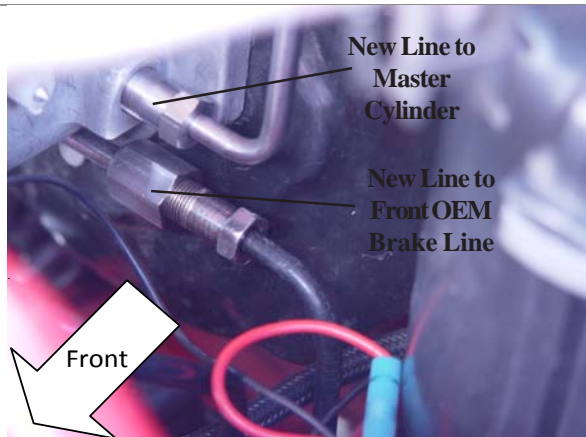

WIRING INSTALLATION

NOTE: The Hurst Roll Control Solenoid Valve is designed for 12V DC operation only. For added safety, two switches (arming and activation) are provided in this kit. Following the wiring recommendation properly will prevent accidental engagement of the Hurst Roll Control system.

Disconnect negative (-) battery terminal. If more wire is needed than what is provided, use #18 gauge standard insulated automotive wire to assure good electrical connection and conductivity. Wiring should be as neat and direct as possible. DO NOT connect wiring in such a fashion as to apply added stress or excessive stretch to wires. Use convoluted sleeve to protect wires, keep wiring away from sharp edges/corners, hot engine, and exhaust components. Join all splices by using the provided connectors/terminals and wrap each splice/connection with an adequate grade of electrical tape. A fuse holder with a 4-amp fuse is provided (See wiring diagrams for wiring details on page 10) and should be incorporated into the wiring circuit. The fuse can protect the electrical system in the event of a short circuit.

STEP 12. *Suggested Solenoid Ground:*

Attach 5/16" eyelet connector to black wire of solenoid and ground wire to bolt on strut tower or another appropriate grounding location.

TOOLS: 13mm Socket, Ratchet, Extension

(See wiring diagrams on page 9)

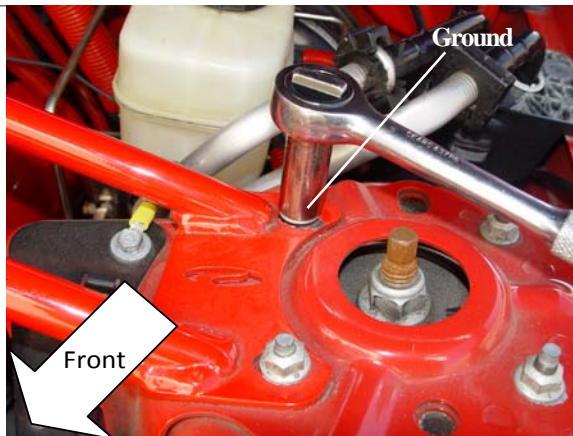

STEP 13. Pass wiring through existing access points (one is located on the driver's side firewall) by going through the grommet of the hood latch release cable.

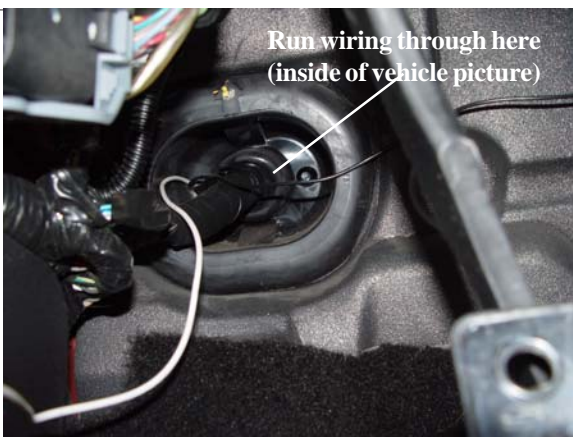

STEP 14. *Suggested 12V Source:*

Tap into a 12V accessory/cigarette lighter socket wiring harness connection with provided Scotchlok™ connector or another appropriate 12V source.

(See wiring diagrams on page 9)

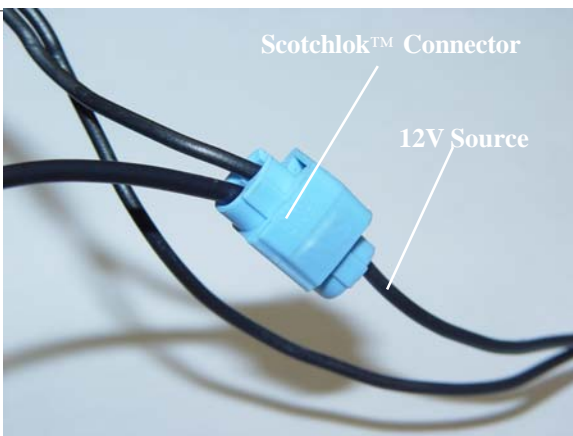

STEP 15. Mount switches in desired location (usually within reach of the driver) and ground momentary switch to an appropriate grounding location with provided 5/16" eyelet.



STEP 16. Reconnect battery and turn ignition switch to the "ON" position. While still in park and NOT depressing your brake pedal, activate and engage your Hurst Roll/Control system (make sure you can hear the clicking of the solenoid) several times and check fuse. If fuse is burned, check all electrical connections for a short and correct any problems immediately.

CAUTION: Before driving vehicle, completely check the brake system for proper operation. Check all connections under pressure for leaks and be sure that you have a good solid brake pedal (bleed brakes again to get a firmer brake pedal). On a flat level surface, Test the Roll Control system several times to be sure that it operates correctly. Be sure that the proper two wheels have the brakes engaged when the Roll Control is actuated and that all four wheels are free when the Roll Control switch is released.

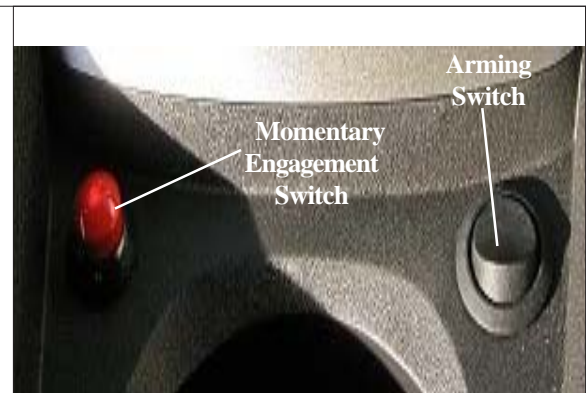

Basic Switch Operation

System Arming: Turn on rocker switch, the momentary switch will light to indicate the Hurst Roll/Control system is ready or "hot".

Solenoid Engagement: Depress and hold momentary switch (Do not hold for more than 60 seconds).

See "Hurst Roll Control Operation" for competition use

Caution: Holding the solenoid valve closed for more than 60 seconds can cause the fuse to burn-out, permanently damaging the solenoid valve, and/or result in other damage. De-activate (switch off) arming switch when the Hurst Roll Control is not in use to prevent accidental engagement.

STEP 17. Before executing a burnout, turn OFF your Traction Control (At a complete stop, press Traction Control button - "TCS OFF" dash light should appear to indicate Traction Control is off.

Note: Turn ON your Traction Control / AdvanceTrac when not using the Hurst Roll Control.

Warning: Performing a burnout without the Traction Control / AdvanceTrac off can damage the vehicle. Also, avoid excessive loading of the clutch, flywheel, and other drivetrain components.



OPERATION INSTRUCTIONS

To actuate the Hurst Roll/Control system (BURNOUT):

1. With the Traction Control System (TCS) OFF, fully depress and hold the brake pedal.
2. Arm the Hurst Roll Control system by depressing the rocker (arm) switch to the "ON" position (the engage button switch should illuminate).
The next steps should be complete within 60 seconds.
3. Hold the illuminated button switch down and keep it held down until step 7 below.
4. Release the brake pedal.
The front brakes will now be locked and the rear wheels un-locked and free to spin.
5. Automatic Vehicles- sharply step on the gas pedal.
Manual Vehicles- raise the engine speed to a moderate level and smoothly but quickly release the clutch.
The rear wheels should now be spinning and the vehicle should be stationary if the above steps have been performed correctly.
6. Modulate the gas pedal to control the amount of wheel spin.
7. Release the illuminated button switch and allow the vehicle to "drive-out" of the burnout.
8. Be prepared to ease off on the gas pedal and press the brake pedal if necessary.
9. Disarm the Hurst Roll Control system by depressing the rocker switch to the "OFF" position (the engage button switch should no longer be illuminated).
10. Press the Traction Control System (TCS) button again and/or restart vehicle to turn on your Traction Control system.

To actuate the Hurst Roll/Control system (LAUNCH CONTROL – Automatic Vehicles Only):

1. With the vehicle staged fully, depress and hold the brake pedal.
2. Arm the Hurst Roll Control system by depressing the rocker (arm) switch to the "ON" position (the engage button switch should illuminate).
The next steps should be complete within 60 seconds.
3. Hold the illuminated button switch down and keep it held down until step 6 below.
4. Release the brake pedal.
The front brakes will now be locked and the rear wheels un-locked and free to be loaded.
5. Slowly and smoothly step on the gas pedal to load the torque converter and drivetrain just prior to wheel spin (this step may take some practice).
6. GO! - Release the illuminated button switch and modulate the gas pedal as the light turns green/flag drops/etc. to hard launch the vehicle forward.
7. Be prepared to ease off on the gas pedal and press the brake pedal if necessary.
8. Disarm the Hurst Roll Control system by depressing the rocker switch to the "OFF" position (the engage button switch should no longer be illuminated).



ENJOY!

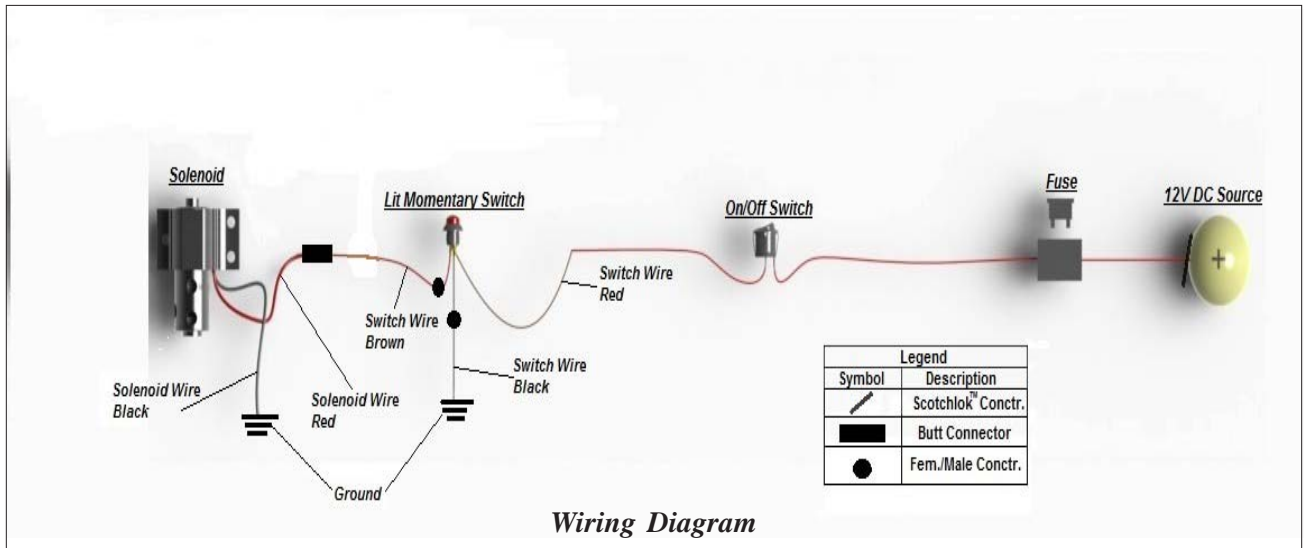

Wiring Diagram

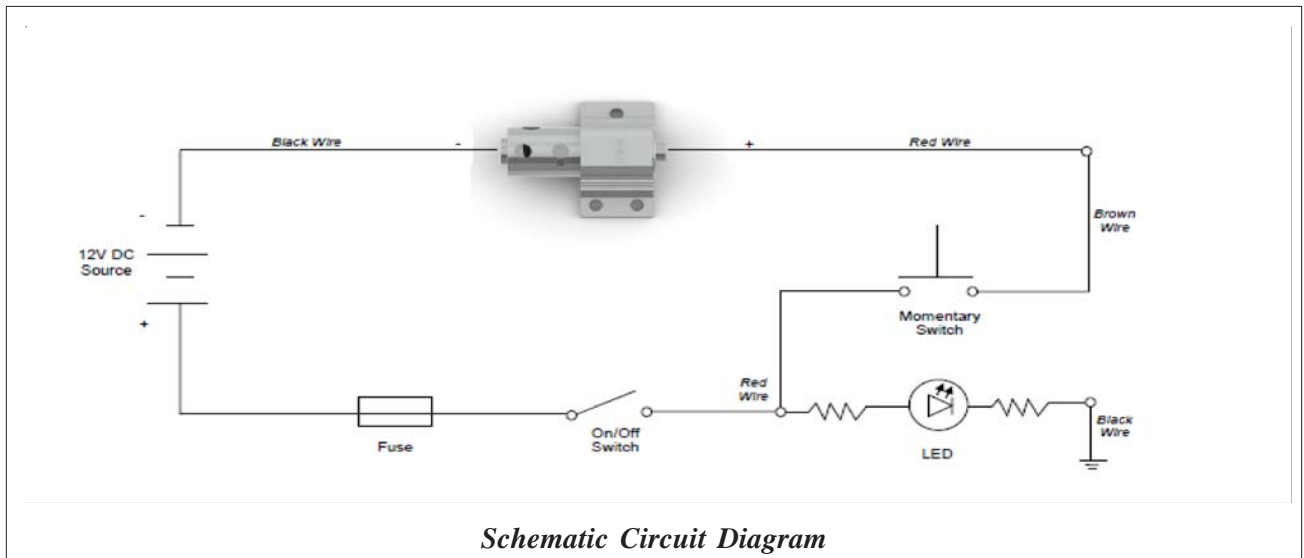

Schematic Circuit Diagram

-- 90 Day Limited Warranty --

Hurst Roll Controls are covered for 90 days from the date of retail purchase to be free from defects in material and workmanship to the original purchaser (not warranted against normal wear, misuse or abuse). This warranty covers the original purchasing consumer. This warranty is limited to repair or replacement by Hurst performance of any Hurst Performance Product that fails because of a defect in materials or workmanship. Implied warranty: Any warranties implied by law are limited to the duration of this warranty, (except in those states where prohibited by law).

NOTE: Complement your Hurst Roll Control with some of the following products. Check the Hurst website at www.hurst-shifters.com for various stick, knob, and handle options:



**Universal Hurst T-Handle
w/ Button
1530011**



**Hurst Switch Kit
#2483876**



**Sidewinder Shift Knob
#1630069**



**Comp/Plus Shifter
Ford Mustang GT
#3910201
For Tremec TR-3650
Transmission**



**HardDrive Stick
5388656 (Black Delrin Handle)
5388665 (Brushed Aluminum Handle)
5388655 (Titanium Anodized handle)
For Manual Transmission
Equipped with Hurst Shifter**



**Billet/Plus Shifter
Ford Mustang V8
For Manual Transmission**

Technical Service

A highly trained technical service department is maintained by Hurst Performance to answer your technical questions, provide additional product information and offer various recommendations.

Technical service calls, correspondence, and warranty questions should be directed to the following address:

Hurst Performance
9142 Independence Ave.
Chatsworth, CA 91311
Phone (818) 882-6422
Monday-Friday 7AM to 4PM PST