

CHEVROLET EQUINOX**REAR MUD GUARD INSTALLATION INSTRUCTIONS**

Please read instructions thoroughly before installation.

Tools Required

- 1/8" drill bit / Drill
- Short #2 Phillips screwdriver

Package Contents

- Driver & passenger side rear mud guard
- #10 SEM screw (qty. 6)
- U-Clip (qty. 6)
- Instruction sheet

NOTE: It may be necessary to remove the rear wheels for mud guard installation.

1. Clean and degrease the mud guard location area on the fender before installation.
2. Remove existing fasteners from locations A and B, pull back fender liner and install u-clips over sheet metal and align with existing holes (Figure 1).
3. Replace liner and attach mud guard to fender with #10 SEM screws, check fit and make sure the mud guard is parallel to the ground before tightening.
4. Using the mud guard as a template, mark and drill 1/8" hole at location C (Figure 1).
5. Install #10 SEM screw at locations C, thru mud guard, fender liner and into a u-clip. **NOTE:** The u-clip acts as a nut and is placed behind fender liner. **DO NOT CLIP OVER LINER PANEL.**

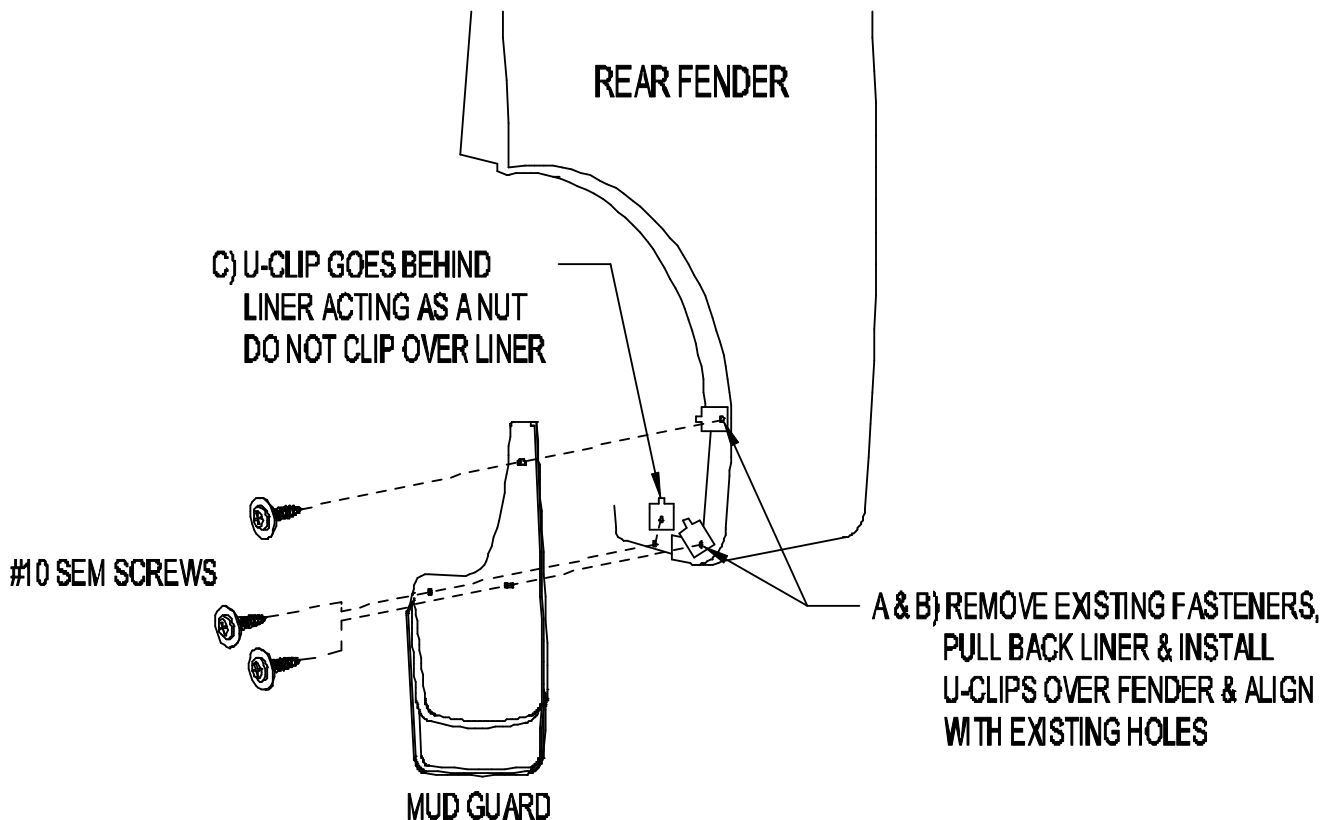

Figure 1

PAINTING INSTRUCTIONS

1. Clean mud guard with a soap and water solution to remove dirt and other contaminants.
2. Sand painting surface with 320 grit sand paper.
3. Apply a coating of flexible primer-adhesion promoter.
4. Apply a flexible paint as directed by the paint manufacturer.