



2021+ Ford Bronco (2.7L & 2.3L Engines)
**“Street Series” Axleback Exhaust
Installation Instructions**



**Thank you for your purchase, we appreciate your business.
If additional assistance is needed, please contact Kooks Headers and Exhaust
Toll free at 1-866-586-KOOK or contact your local dealer.**

- System Layout -

Components to ship with-

3) JI-TAS250

OEM

JI-TAS250

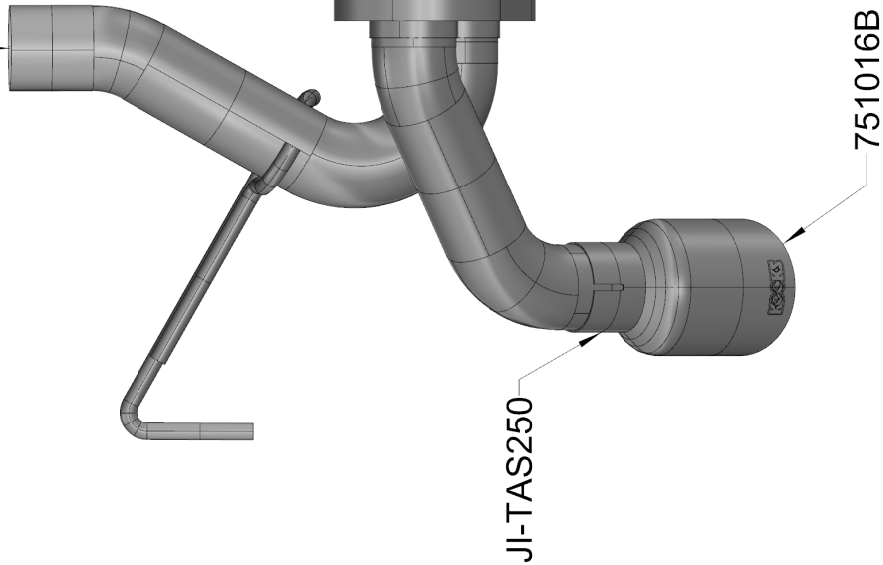

15016210

2021 Bronco
axleback - 2.3L & 2.7L Engines
dual black tips



Do not attempt this installation if proper safety equipment is not available to you - seek the assistance of a professional installer

Read and understand all instructions before beginning

Vehicle Preparation

****Raise and Support Vehicle (Refer to Owner's Manual for specified jacking points) ****

Always disconnect the battery before performing this type of work on any vehicle

2 Post Lift Recommended

KOOKS "Street Series" Axleback Exhaust Installation

Part # 15016210

- Step 1** - Use penetrating fluid on rubber isolators holding up muffler.
- Step 2** - Remove OEM Clamp on OEM Overaxle pipe and Muffler joint. Clamp will be tacked on tube and will need to be cut off.
- Step 3** - Support the Muffler while removing hangers from rubber isolators - Remove OEM Muffler.
- Step 4** - Determine engine size - For 2.7L engines continue to step 5.
For 2.3L engines install 2.3L Bronco Axleback Hanger using OEM bolts (See Pages 4 & 5)
- Step 5** - Apply anti-seize to the threads of all band clamps (JI-TAS250)
- Step 6** - Place one Band Clamp (JI-TAS250) onto Overaxle pipe - leave loose as this time
- Step 7** - Place Muffler hangers into rubber isolators while sliding inlet onto the Overaxle tube.
- Step 8** - Tighten Band Clamp (JI-TAS250) onto inlet of Muffler at Overaxle.
- Step 9** - Slide Band Clamps onto outlet tubes - Place Tips onto outlet tubes and align while tightening Band Clamps.
- Step 10** - Test system for leaks. Allow vehicle to complete one heat cycle (heat to operating temperatures and allow for cooling). Re-torque clamps.

Thank you for your purchase, we appreciate your business.

If additional assistance is needed, please contact Kooks Headers and Exhaust

Toll free at 1-866-586-KOOK or contact your local dealer.



To install 2.3L Engine Hanger complete the following steps-

- **Remove Spare Tire**
- **Remove Rear Bumper Cover (follow steps below)**

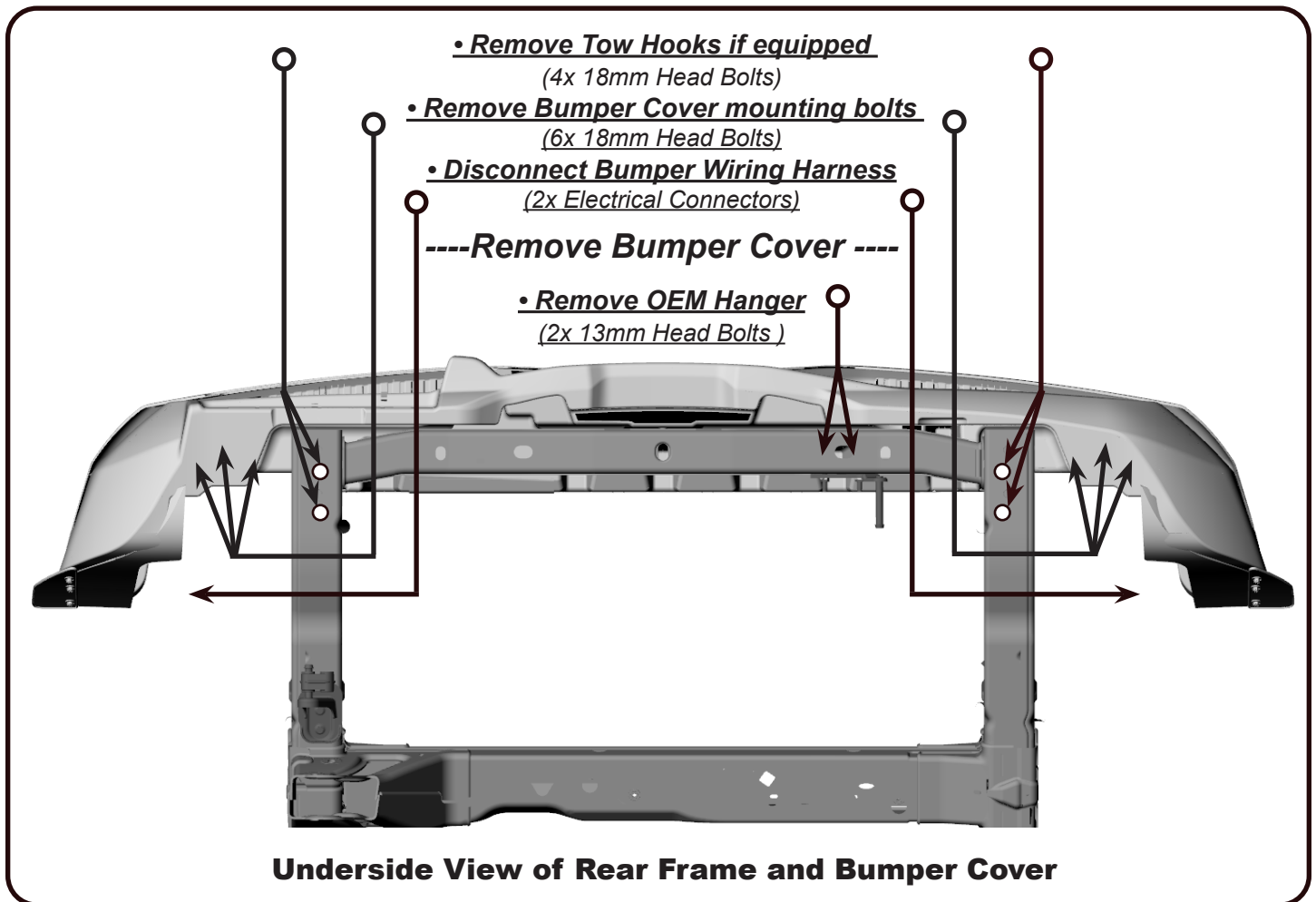

Thank you for your purchase, we appreciate your business.
If additional assistance is needed, please contact Kooks Headers and Exhaust
Toll free at 1-866-586-KOOK or contact your local dealer.



Install KOOKS Bronco Axleback 2.3L Hanger

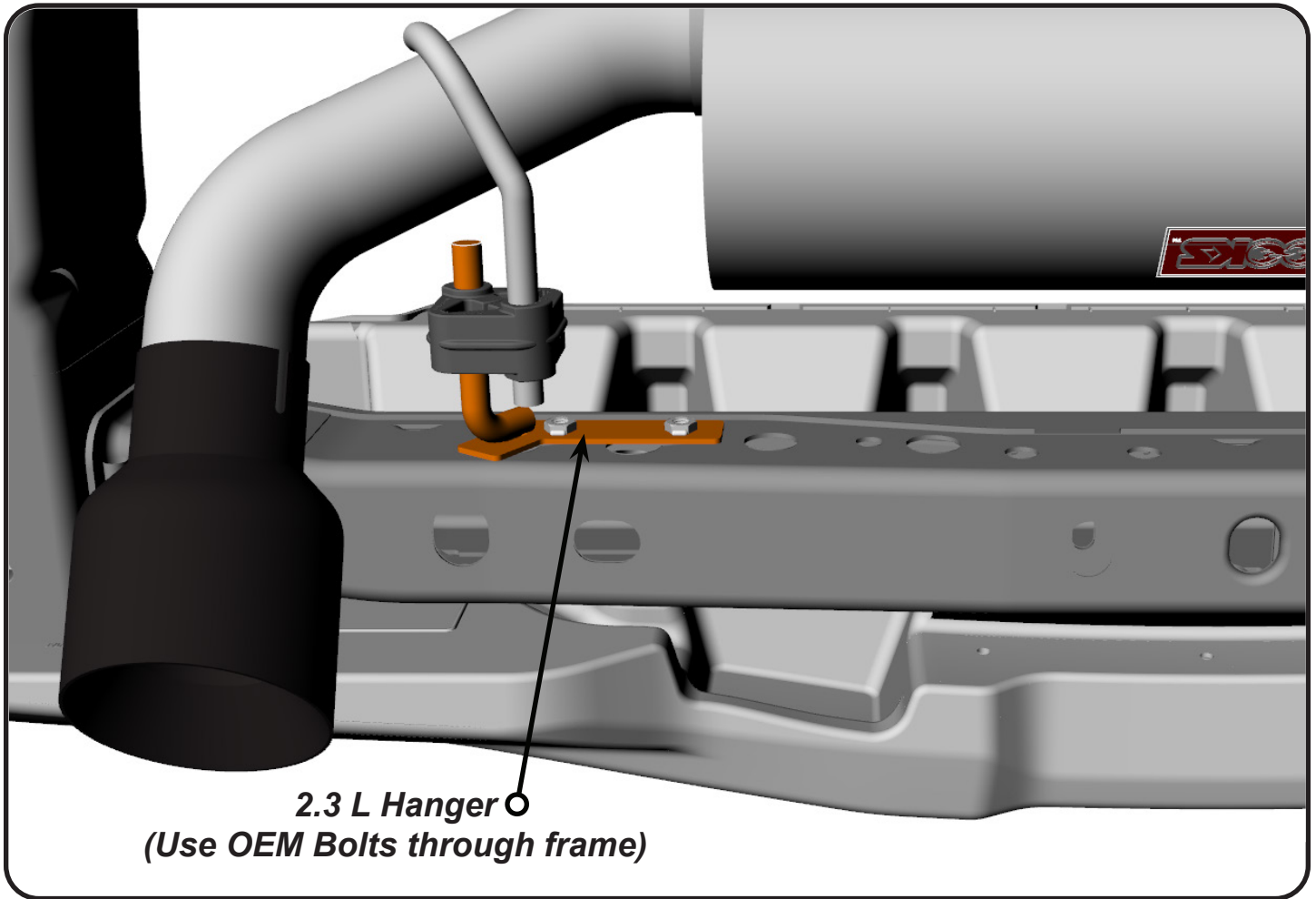

Return to Page 3 - Step #5

Thank you for your purchase, we appreciate your business.
If additional assistance is needed, please contact Kooks Headers and Exhaust
Toll free at 1-866-586-KOOK or contact your local dealer.